

TURCK

Industrial
Automation

**USER MANUAL
BLXX –
CANOPEN-
OBJECT
REGISTER**

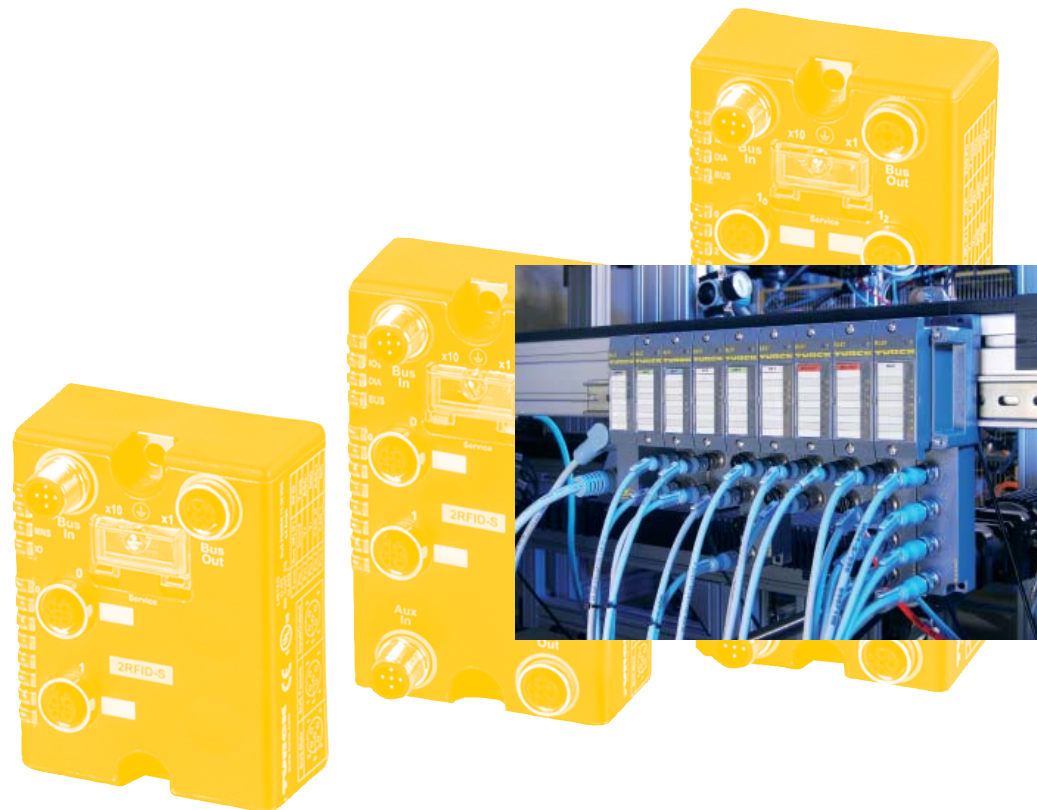

Sense it! Connect it! Bus it! Solve it!

All brand and product names are trademarks or registered trade marks of the owner concerned.

Edition 0511

© Hans Turck GmbH, Muelheim an der Ruhr

All rights reserved, including those of the translation.

No part of this manual may be reproduced in any form (printed, photocopy, microfilm or any other process) or processed, duplicated or distributed by means of electronic systems without written permission of Hans Turck GmbH & Co. KG, Muelheim an der Ruhr.

Subject to alterations without notice

Warning!

Before commencing the installation

- Disconnect the power supply of the device.
- Ensure that devices cannot be accidentally restarted.
- Verify isolation from the supply.
- Earth and short circuit.
- Cover or enclose neighboring units that are live.
- Follow the engineering instructions of the device concerned.
- Only suitably qualified personnel in accordance with EN 50 110-1/-2 (VDE 0 105 Part 100) may work on this device/system.
- Before installation and before touching the device ensure that you are free of electrostatic charge.
- The functional earth (FE) must be connected to the protective earth (PE) or to the potential equalization. The system installer is responsible for implementing this connection.
- Connecting cables and signal lines should be installed so that inductive or capacitive interference do not impair the automation functions.
- Install automation devices and related operating elements in such a way that they are well protected against unintentional operation.
- Suitable safety hardware and software measures should be implemented for the I/O interface so that a line or wire breakage on the signal side does not result in undefined states in the automation devices.
- Ensure a reliable electrical isolation of the low voltage for the 24 volt supply. Only voltage supplies which meet the requirements of IEC 60 364-4-41 or. HD 384.4.41 S2 (VDE 0100 part 410).
- Deviations of the mains voltage from the rated value must not exceed the tolerance limits given in the specifications, otherwise this may cause malfunction and dangerous operation.
- Emergency stop devices complying with IEC/EN 60 204-1 must be effective in all operating modes of the automation devices. Unlatching the emergency-stop devices must not cause restart.
- Devices that are designed for mounting in housings or control cabinets must only be operated and controlled after they have been installed with the housing closed.
- Measures should be taken to ensure the proper restart of programs interrupted after a voltage dip or failure. This should not cause dangerous operating states even for a short time. If necessary, emergency-stop devices should be implemented.
- Wherever faults in the automation system may cause damage to persons or property, external measures must be implemented to ensure a safe operating state in the event of a fault or malfunction (for example, by means of separate limit switches, mechanical interlocks etc.).
- The electrical installation must be carried out in accordance with the relevant regulations (e. g. with regard to cable cross sections, fuses, PE).
- All work relating to transport, installation, commissioning and maintenance must only be carried out by qualified personnel. (respect IEC 60 364 or HD 384 or DIN VDE 0100 and national work safety regulations).
- All shrouds and doors must be kept closed during operation.

Table of Contents

1	About this manual	
1.1	Documentation concept	1-2
1.1.1	Additional documentation	1-2
1.2	General	1-2
1.2.1	Prescribed use	1-2
1.2.2	Notes concerning planning/ installation of this product	1-2
1.3	Description of symbols used	1-3
2	CANopen	
2.1	CANopen	2-2
2.1.1	General	2-2
2.1.2	Communication	2-2
2.2	EDS-file – Electronic data sheet	2-5
2.3	BLxx and CANopen	2-5
2.3.1	Setting up communication	2-5
2.3.2	Parameterization through Service Data Objects (SDO)	2-10
2.3.3	Transmission of Process Data Objects (PDO)	2-14
2.3.4	Inhibit Time	2-16
2.3.5	Event Timer	2-16
2.3.6	Mapping Objects in PDOs	2-16
2.3.7	Commands for "Parameter Save" and "Restore Defaults"	2-24
3	Object dictionary - overview of all objects	
3.1	Overview of all objects	3-2
4	Device (gateway) objects	
4.1	Objects of the Communication Profile (acc. to CiA DS-301)	4-2
4.1.1	Object 1000 _{hex} – Device Type	4-5
4.1.2	Object 1001 _{hex} – Error Register	4-5
4.1.3	Object 1005 _{hex} – SYNC COB-ID	4-6
4.1.4	Object 1008 _{hex} – Device Name	4-7
4.1.5	Object 1009 _{hex} – Manufacturer Hardware Version	4-8
4.1.6	Object 100A _{hex} – Manufacturer Software Version	4-8
4.1.7	Object 100C _{hex} – Guard Time	4-9
4.1.8	Object 100D _{hex} – Lifetime Factor	4-9
4.1.9	Object 1010 _{hex} – Store Parameters	4-10
4.1.10	Object 1011 _{hex} – Restore Default Parameters	4-11
4.1.11	Object 1014 _{hex} – Emcy COB-ID	4-12
4.1.12	Object 1016 _{hex} – Consumer Heartbeat Time	4-13
4.1.13	Object 1017 _{hex} – Producer Heartbeat Time	4-15
4.1.14	Object 1018 _{hex} – Identity Object	4-16
4.1.15	Object 1020 _{hex} – Verify Configuration	4-17
4.1.16	Object 1027 _{hex} – Module List	4-19
4.2	Objects for the Transfer of Service Data	4-20
4.2.1	Objects 1200 _{hex} to 1203 _{hex} – Server SDO Default Parameters	4-20

4.3	Objects for the Transfer of Process Output Data	4-21
4.3.1	Object 1400 _{hex} to 141F _{hex} – Receive PDO Comm. Default Parameters.....	4-21
4.3.2	Object 1600 _{hex} to 161F _{hex} – Receive PDO-Mapping Parameter	4-24
4.4	Objects for the Transfer of Process Input Data	4-27
4.4.1	Object 1800 _{hex} to 181F _{hex} – Transmit PDO-Parameters	4-27
4.4.2	Objects 1A00 _{hex} to 1A1F _{hex} - Transmit PDO Mapping Parameter.....	4-30
4.5	Objects for network management (not valid for BLCCO)	4-33
4.5.1	Object 1F80 _{hex} – NMT Start-up.....	4-33
4.5.2	Object 1F81 _{hex} – Slave Assignment.....	4-34
4.5.3	Object 1F82 _{hex} – Request NMT.....	4-36
4.5.4	Object 1F83 _{hex} – Request Guarding	4-38
4.6	Overview about the objects of the Device Profile (acc. to CiA DS-401 and 406)	4-39
4.6.1	Object 67FF _{hex} – Device Type.....	4-39
4.6.2	Object 6FFF _{hex} – Device Type.....	4-40
4.7	Manufacturer specific device objects.....	4-40
4.7.1	Object 2000 _{hex} – Serial Number	4-40
4.7.2	Object 2010 _{hex} – Node ResetModifiers.....	4-41
4.7.3	Object 2400 _{hex} - System Voltages (only BL67)	4-45
4.7.4	Object 2401 _{hex} - System Currents (only BL67)	4-45
5	Objects for digital input modules	
5.1	Digital input modules BLxx	5-2
5.2	General object overview for digital input modules	5-2
5.2.1	Object 6000 _{hex} – Read Input 8 Bit.....	5-4
5.2.2	Object 6020 _{hex} – Read Input Bit (1 to 128), Object 6021 _{hex} – Read Input Bit (129 to 256), Object 6022 _{hex} – Read Input Bit (257 to 288)	5-5
5.2.3	Object 6100 _{hex} – Read Input 16 Bit	5-6
5.2.4	Object 6120 _{hex} – Read Input 32 Bit	5-6
6	Objects for digital output modules	
6.1	Digital output modules BLxx.....	6-2
6.2	General object overview for digital output modules	6-3
6.2.1	Object 6200 _{hex} – Write Output 8 Bit	6-4
6.2.2	Object 6206 _{hex} – Error Mode Output 8 Bit	6-5
6.2.3	Object 6207 _{hex} – Error State Output 8 Bit.....	6-6
6.2.4	Object 6220 _{hex} – Write Output Bit (1 to 128), Object 6221 _{hex} – Write Output Bit (129 to 256), Object 6222 _{hex} – Write Output Bit (257 to 288).....	6-7
6.2.5	Object 6250 _{hex} – Error Mode Output Bit (1 to 128), Object 6251 _{hex} – Error Mode Output Bit (129 to 256), Object 6252 _{hex} – Error Mode Output Bit (257 to 288)	6-8
6.2.6	Object 6260 _{hex} – Error State Output Bit (1 to 128), Object 6261 _{hex} – Error State Output Bit (129 to 256), Object 6262 _{hex} – Error State Output Bit (257 to 288)	6-9
6.2.7	Object 6300 _{hex} – Write Output 16 Bit.....	6-10
6.2.8	Object 6306 _{hex} – Error Mode Output 16 Bit.....	6-10
6.2.9	Object 6307 _{hex} – Error State Output 16 Bit	6-11
6.2.10	Object 6320 _{hex} – Write Output 32 Bit.....	6-12
6.2.11	Object 6326 _{hex} – Error Mode Output 32 Bit.....	6-13
6.2.12	Object 6327 _{hex} – Error State Output 32 Bit	6-14

7	Objects for digital combi modules	
7.1	Digital combi modules BLxx	7-2
7.2	General object overview for digital combi modules	7-2
8	Objects for analog input modules	
8.1	Analog input modules BLxx	8-2
8.2	General object overview for analog input modules	8-2
8.2.1	Object 5420 _{hex} – Manu Spec Analog Input Range.....	8-3
8.2.2	Object 6401 _{hex} – Read Analog Input 16 Bit	8-10
8.2.3	Object 6421 _{hex} – Analog Input Interrupt Trigger Selection	8-11
8.2.4	Object 6422 _{hex} – Analog Input Interrupt Source.....	8-13
8.2.5	Object 6423 _{hex} – Analog Input Global Interrupt Enable.....	8-14
8.2.6	Object 6424 _{hex} – Analog Input Interrupt Upper Limit Integer	8-14
8.2.7	Object 6425 _{hex} – Analog Input Interrupt Lower Limit Integer	8-15
8.2.8	Object 6426 _{hex} – Analog Input Interrupt Delta Unsigned	8-15
8.2.9	Object 6427 _{hex} – Analog Input Interrupt Negative Delta Unsigned	8-16
8.2.10	Object 6428 _{hex} – Analog Input Interrupt Positive Delta Unsigned.....	8-16
9	Objects for analog output modules	
9.1	Analog output modules BLxx	9-2
9.2	General object overview for analog output modules	9-2
9.2.1	Object 5440 _{hex} – Manu Spec Analog Output Range.....	9-4
9.2.2	Object 6411 _{hex} – Write Analog Output 16 Bit.....	9-6
9.2.3	Object 6443 _{hex} – Analog Output Error Mode	9-7
9.2.4	Object 6444 _{hex} – Analog Output Error State.....	9-8
10	Objects for RS232/RS4xx modules	
10.1	RSxxx modules BLxx	10-2
10.2	Allgemeine Objektübersicht für RS232/RS4xx-Module	10-2
10.2.1	Object 5600 _{hex} – RS232/RS4xx Parameters	10-2
10.2.2	Object 5601 _{hex} – RS232/RS4xx RxD	10-4
10.2.3	Object 5602 _{hex} – RS232/RS4xx TxD	10-7
11	Objects for Encoder modules (SSI, CNT)	
11.1	Encoder module BLxx	11-4
11.2	General object overview for encoder modules.....	11-4
11.2.1	Object 5800 _{hex} – Encoder Basic Mode	11-6
11.2.2	Object 5801 _{hex} – Encoder Config	11-7
11.2.3	Object 5802 _{hex} – Encoder Status.....	11-11
11.2.4	Object 5803 _{hex} – Encoder Flags.....	11-13
11.2.5	Objekt 5804 _{hex} – Encoder Diag.....	11-15
11.2.6	Object 5805 _{hex} – Encoder Native Status.....	11-16
11.2.7	Object 5806 _{hex} – Optional Encoder Status	11-18
11.2.8	Object 5808 _{hex} – Encoder Control	11-19
11.2.9	Object 5810 _{hex} – Encoder Load Prepare Value	11-21
11.2.10	Object 5811 _{hex} – Encoder Pulse Width	11-22
11.2.11	Object 5820 _{hex} – Measuring Integration Time	11-22
11.2.12	Object 5821 _{hex} – Measuring Low Limit.....	11-23

11.2.13	Object 5822 _{hex} – Measuring High Limit	11-25
11.2.14	Object 5823 _{hex} – Measuring Units Per Revolution	11-25
11.2.15	Object 5824 _{hex} – Measuring Divisor	11-26
11.2.16	Object 5825 _{hex} – Measuring Factor	11-27
11.2.17	Object 5827 _{hex} – Measuring Timeout	11-27
11.2.18	Object 5830 _{hex} – Measuring Value.....	11-28
11.2.19	Object 5831 _{hex} – Encoder Latch Value.....	11-29
11.2.20	Object 5840 _{hex} – Diag Mapping.....	11-29
11.2.21	Object 5901 _{hex} – PWM Config.....	11-31
11.2.22	Object 5902 _{hex} – PWM Status	11-33
11.2.23	Object 5903 _{hex} – PWM Flags	11-34
11.2.24	Object 5904 _{hex} – PWM Diag.....	11-35
11.2.25	Object 5908 _{hex} – PWM Control.....	11-36
11.2.26	Object 5910 _{hex} – PWM Load Prepare Value.....	11-38
11.2.27	Object 5913 _{hex} – PWM Duty Cycle	11-39
11.2.28	Object 5920 _{hex} – PWM Period Duration	11-39
11.2.29	Object 5931 _{hex} – PWM Latch Value.....	11-40
11.2.30	Object 6800 _{hex} – Operating Parameters	11-40
11.2.31	Objekt 6810 _{hex} – Preset Values for Multi-Sensor Devices.....	11-41
11.2.32	Object 6820 _{hex} – Position Value.....	11-42
11.2.33	Object 6B00 _{hex} – CAM State Register	11-42
11.2.34	Object 6B01 _{hex} – CAM1 Enable Register	11-44
11.2.35	Object 6B02 _{hex} – CAM Polarity Register	11-45
11.2.36	Object 6B10 _{hex} – CAM1 Low Limit	11-46
11.2.37	Object 6B20 _{hex} – CAM1 High Limit	11-47
11.2.38	Object 6B30 _{hex} – CAM1 Hysteresis.....	11-48
11.2.39	Object 6C00 _{hex} – Area State Register	11-49
11.2.40	Object 6C01 _{hex} – Work Area Low Limit.....	11-50
11.2.41	Object 6C02 _{hex} – Work Area High Limit	11-51
11.2.42	Object 6D00 _{hex} – Operating Status, Object 6D01 _{hex} – SingleTurn Resolution (rotary), Measuring step (linear), Object 6D02 _{hex} – Number of Distinguishable Revolutions	11-52
11.2.43	Object 6FFF _{hex} – Device Type	11-52
11.3	Process output/ control interface of the Encoder modules.....	11-52
11.3.1	Meaning of the process output bits of BLxx-1SSI	11-52
11.3.2	Meaning of the process output bits of BL20-1CNT-24VDC	11-53
11.3.3	Meaning of the process output bits of BL20-E-2CNT-2PWM	11-56
11.3.4	Meaning of the process output bits of BL67-1CNT/ENC	11-58
11.4	Meaning of the process input bits of the Encoder modules.....	11-59
11.4.1	Meaning of the process input bits of BLxx-1SSI	11-59
11.4.2	Meaning of the process input bits of BL20-1CNT-24VDC	11-61
11.4.3	Meaning of the process input bits of BL20-E-2CNT-2PWM	11-63
11.4.4	Meaning of the process input bits of BL67-1CNT/ENC	11-66
11.5	Parameter interface of the Encoder modules.....	11-67
11.5.1	Meaning of the parameter bits of BLxx-1SSI	11-67
11.5.2	Meaning of the parameter bits of BL20-1CNT-24VDC.....	11-69
11.5.3	Meaning of the parameter bits of BL20-E-2CNT-2PWM	11-71
11.5.4	Meaning of the parameter bits of BL67-1CNT/ENC.....	11-74
11.6	Diagnostic interface of the Encoder modules	11-76
11.6.1	Meaning of the diagnostic bits of BLxx-1SSI	11-76
11.6.2	Meaning of the diagnostic bits of BL20-1CNT-24VDC.....	11-77
11.6.3	Meaning of the diagnostic bits of BL20-E-2CNT-2PWM	11-78
11.6.4	Meaning of the diagnostic bits of BL67-1CNT/ENC.....	11-79

12	Objects for SWIRE modules	
12.1	Motor starter modules BL20	12-2
12.2	General object overview for SWIRE modules	12-2
12.2.1	Representation of process input data.....	12-3
12.2.2	Representation of process output data	12-4
12.2.3	Representation of diagnostic data.....	12-6
12.2.4	Representation of parameter data.....	12-10
13	Objects for RFID-modules	
13.1	RFID-S-module BL20	13-2
13.2	General object overview for RFID-S-modules	13-2
13.3	Object 5700 _{hex} - 8 byte process input data	13-2
13.4	Object 5701 _{hex} - 12 byte process input data.....	13-3
13.5	Object 5702 _{hex} - 8 byte process output data	13-3
13.6	Object 5703 _{hex} - 12 byte process output data	13-4
13.7	Object 5708 _{hex} - 1 byte status messages.....	13-4
13.8	Object 5722 _{hex} - 1 byte parameter	13-5
14	Manufacturer specific objects	
14.1	General	14-2
14.1.1	Module related manufacturer specific objects.....	14-2
14.1.2	Slot-related manufacturer specific objects	14-4
14.1.3	Process input objects	14-5
14.1.4	Process output objects	14-6
14.1.5	Diagnosis objects	14-8
14.1.6	Parameter objects	14-9
15	Diagnostics - Emergency Frames	
15.1	General	15-2
15.2	Structure of the emergency frames	15-2
15.2.1	Emergency Error-Codes	15-2
15.2.2	Error register.....	15-4
15.3	Emergency codes for module diagnostics.....	15-5
15.3.1	General module error codes.....	15-5
15.3.2	Digital output modules	15-5
15.3.3	Analog Input Modules.....	15-6
15.3.4	Technology modules	15-8
16	Index	

1 About this manual

1.1	Documentation concept.....	2
1.1.1	Additional documentation	2
	– BL67	2
	– BL20	2
	– BLC.....	2
1.2	General	2
1.2.1	Prescribed use.....	2
1.2.2	Notes concerning planning/ installation of this product.....	2
1.3	Description of symbols used	3

1.1 Documentation concept

This manual describes the CANopen object directory for TURCK BLxx-products.

If not marked especially, the object descriptions are valid for all products of the product lines BL20, BL67 and BLcompact.

1.1.1 Additional documentation

BL67

- [D301006](#) - BL67 – User manual for CANopen
- Data sheets for the BL20-products www.turck.com

BL20

- [D301108](#) BL20 – ECO gateway for CANopen
- [D301109](#) - BL20 – User manual for CANopen
- Data sheets for the BL20-products www.turck.com

BLC

- Manuals and data sheets for the BLC-CANopen-products www.turck.com

1.2 General



Attention

Please read this section carefully. Safety aspects cannot be left to chance when dealing with electrical equipment.

1.2.1 Prescribed use

Appropriate transport, storage, deployment and mounting as well as careful operating and thorough maintenance guarantee the trouble-free and safe operation of these devices.



Danger

The devices described in this manual must be used only in applications prescribed in this manual or in the respective technical descriptions, and only with certified components and devices from third party manufacturers.

1.2.2 Notes concerning planning/ installation of this product



Danger

All respective safety measures and accident protection guidelines must be considered carefully and without exception.

1.3 Description of symbols used



Danger

This sign can be found next to all notes that indicate a source of hazards. This can refer to danger to personnel or damage to the system (hardware and software) and to the facility.

This sign means for the operator: work with extreme caution.



Attention

This sign can be found next to all notes that indicate a potential hazard.

This can refer to possible danger to personnel and damages to the system (hardware and software) and to the facility.



Note

This sign can be found next to all general notes that supply important information about one or more operating steps.

These specific notes are intended to make operation easier and avoid unnecessary work due to incorrect operation.

2 CANopen

2.1	CANopen	2
2.1.1	General	2
2.1.2	Communication	2
	– Network Management Messages	2
	– Service Data Objects (SDOs).....	3
	– Process Data Objects (PDOs)	3
	– Special Function Objects	4
2.2	EDS-file – Electronic data sheet.....	5
2.3	BLxx and CANopen	5
2.3.1	Setting up communication	5
	– Minimum Boot-up.....	5
	– Identifier for the Standard Objects	8
	– Set up Node Guarding Protocol	9
	– Boot-up Message	10
2.3.2	Parameterization through Service Data Objects (SDO)	10
	– Write (Write to Object Dictionary)	12
	– Parameter Storing/Restoring	13
2.3.3	Transmission of Process Data Objects (PDO)	14
	– Communication parameter COB-ID	14
	– Transmission Type	15
2.3.4	Inhibit Time	16
2.3.5	Event Timer.....	16
	– Available PDOs	16
2.3.6	Mapping Objects in PDOs	16
	– Default-PDOs and PDO-mappings.....	17
	– BLxx-spezifische Default-PDOs (gilt nicht für BL compact)	18
	– Mappable Objects	22
	– Procedure for Altering PDO-Mappings	23
2.3.7	Commands for "Parameter Save" and "Restore Defaults"	24

2.1 CANopen



Note

The following description of CANopen is an excerpt from the homepage of CiA (CAN in Automation), the international users' and manufacturers' organization for CAN.

2.1.1 General

CANopen is an open, non-proprietary network protocol. It consists of a profile family, based on a communication profile and several device profiles. The CANopen communication profile is standardized as CiA DS-301 (Application Layer and Communication Profile).

The CANopen device profile for I/O-modules has been published as CiA DS-401 (Device Profile for I/O-Modules).

CANopen is based on the following standards:

- ISO 11 898 (Physical and Data Link Layer) Layers 1 and 2 of the ISO/OSI communication model
- CiA DS-301 (Application Layer and Communication Profile) CANopen communication profile
- CiA DS-302 (Framework for Programmable CANopen Devices) CANopen Network Management NMT
- CiA DS-401 (Device Profile for I/O-modules)
- CiA DS-406 (Device Profile for Encoders) CANopen device profile for counter modules
- CiA DS-102 (CAN Physical Layer for Industrial Applications) General application in the field sector (connectors and bit rates) on the basis of ISO 11898

2.1.2 Communication

The lower layers of CANopen are defined according to the ISO-OSI model in the ISO 11898 standard.

Communication between the individual nodes is made by transmitting "Telegrams".

4 different types of telegram message are defined for CANopen:

- Network management messages
- Service data objects SDO
- Process data objects PDO
- Predefined messages

Network Management Messages

Network management messages are used in the network to control the nodes and their operating states. This type of message makes it possible, for instance, to configure the data transmission mechanism of a node.

The Network Management objects include Boot-up message, Heartbeat protocol and NMT message.

Boot-up message, Heartbeat and Node Guarding are implemented as single CAN frames with 1-byte data field.

The NMT message is mapped to a single CAN frame with a data length of 2 byte. The CAN-Identifier is 0. The first byte contains the command specifier and the second contains the Node-ID of the device that must perform the command (in the case of Node-ID 0 all nodes have to perform the command). The NMT message transmitted by the NMT master forces the nodes to transit to another NMT state. CANopen defines the following status: "Initialization", "Pre-Operational", "Operational" and "Stopped".

After a "power-on", each CANopen device is in the status "Initialization" and automatically changes to the Pre-Operational status. In this state the transmission of SDOs is allowed. If the NMT master has set one or more nodes into the state Operational, they are allowed to transmit and to receive PDOs. In the state Stopped no communication is allowed except that of NMT objects.

The state Initialization is divided into 3 sub-states, in order to enable a complete or partial reset of a node. In the sub-state Reset Application the parameters of the manufacturer-specific profile area and the standardized device profile area are set to their power-on values. In the sub-state Reset Communication the parameters of the communication profile area are set to their power-on values. The third sub-state is initializing, which a node enters automatically after power-on. Power-on values are the last stored parameters.

The **Heartbeat** protocol and **Node Guarding** (see [Set up Node Guarding Protocol \(page 2-9\)](#)) are for error control purposes and signals the presence of a node and its state. The Heartbeat message is a periodic message of the node to one or several other nodes. It indicates that the sending node is still working properly.

A device sends the **Boot-up message** to indicate to the NMT master that it has changed from „Initialization“ to the state Pre-operational. This occurs whenever the device initially boots-up but also after a power-out during operation. The Boot-up message has the same identifier as the Heartbeat object, however, its data content is zero.

Service Data Objects (SDOs)

A Service Data Object (SDO) reads from entries or writes to entries of the Object Dictionary.

The SDO transport protocol allows transmitting objects of any size. The first byte of the first segment contains the necessary flow control information including a toggle bit to overcome the problem of doubly received CAN frames. The next three bytes of the first segment contain index and sub-index of the Object Dictionary entry to be read or written. The last four bytes of the first segment are available for user data. The second and the following segments (using the very same CAN identifier) contain the control byte and up to seven bytes of user data. The receiver confirms each segment or a block of segments, so that a peer-to-peer communication (client/server) takes place.

Process Data Objects (PDOs)

Process Data Objects (PDOs) are mapped to a single CAN frame using up to 8 bytes of the data field to transmit application objects. Each PDO has a unique identifier and is transmitted by only one node, but it can be received by more than one (producer/consumer communication). PDO transmissions may be driven by an internal event, by an internal timer, by remote requests and by the Sync message received:

PDO transmissions

- „Event-“ or „timer-driven“:
An event (specified in the device profile) triggers message transmission. An elapsed timer additionally triggers the periodically transmitting of PDO-messages, even if no event has occurred.
- Remotely requested (RTR):
Another device may initiate the transmission of an asynchronous PDO by sending a remote transmission request (remote frame).
- Sync Master (Synchronous transmission):
In order to initiate simultaneous sampling of input values of all nodes, a periodically transmitted Sync message is required. Synchronous transmission of PDOs takes place in cyclic and acyclic transmission mode. Cyclic transmission means that the node waits for the Sync message, after which it sends its measured values. Acyclically transmitted synchronous PDOs are triggered by a defined application-specific event. The device transmits its input values. Further transmission is only done if a further Sync message occurs.

Special Function Objects

CANopen also defines three specific protocols for synchronization, emergency indication, and time-stamp transmission.

- **Synchronization object (Sync)**

The Sync Object is broadcast periodically by the Sync Producer. This object is a central timer. The Sync Object is broadcast periodically by the Sync Producer. The time period between Sync messages is defined by the Communication Cycle Period, which may be reset by a configuration tool to the application devices during the boot-up process. There can be a time jitter in transmission by the Sync Producer due to some other objects with higher prior identifiers or by one frame being transmitted just before the Sync message. The Sync message is mapped to a single CAN frame with the identifier 128 by default.

- **Emergency object (Emcy)**

The Emergency message is triggered by the occurrence of a device internal error situation and are transmitted from an Emergency producer on the concerned application device. This makes them suitable for interrupt type error alerts. An Emergency message is transmitted only once per 'error event'. As long as no new errors occurs on a device, no further Emergency message can be transmitted. Zero or more Emergency consumers may receive these. The reaction of the Emergency consumer is application-specific. CANopen defines several Emergency Error Codes to be transmitted in the Emergency message, which is a single CAN frame with 8 data byte.

- **Time stamp object (Time)**

By means of Time-Stamp, a common time frame reference is provided to application devices. It contains a value of the type Time-of-Day. This object transmission follows the producer/consumer push model. The associated CAN frame has the pre-defined identifier 256 and a data field of 6-byte length.

2.2 EDS-file – Electronic data sheet

CANopen nodes are embedded in the CANopen structure by the help of a standardized EDS file (Electronic Data Sheet).

The EDS file lists all necessary Objects with their corresponding Sub-indices and the matching entries.

The latest version of a particular EDS file can be downloaded directly from the TURCK homepage www.turck.com.

2.3 BLxx and CANopen

BLxx supports the following CANopen-functions:

- SDO transfer, any length of information
- Emergency object
- Sync frame evaluation
- Event-driven PDOs
- Synchronous PDOs (clock-synchronous)
- Remote-requested PDO/polling

2.3.1 Setting up communication

Minimum Boot-up

BLxx supports the Minimum Boot-up function described in CiA DS-301.

Table 1:
Meaning of the abbreviations

Abbreviation	Meaning	Description
cs	NMT command specifier	A designation label for the required service
Node-ID	Node Identifier	Identifier for the node; an identification byte that is set through the DIP switches for the CAN node.

Booting with the Minimum Boot-up function is the typical application option for CANopen, and runs according to the following state diagram:

Figure1:
Boot procedure with Minimum Boot-up

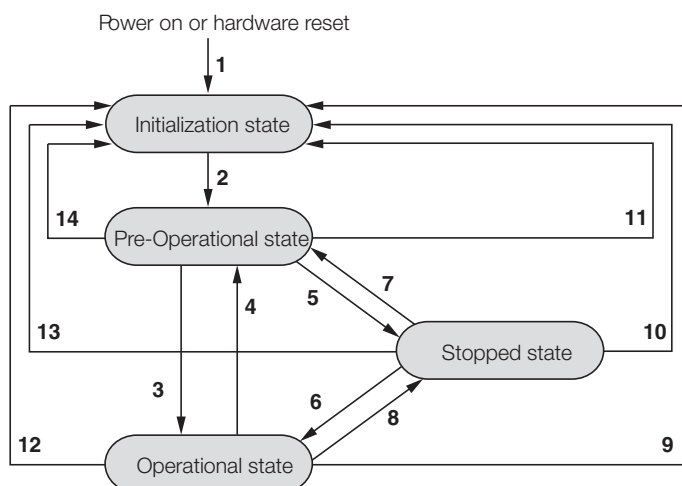

- 1 Power-on (automatic change of state to the "Initialization" condition)
- 2 Initialization Finished (automatic change of state to "Pre-Operational")
- 3 Start Remote Node (start the CAN node)
- 4 Enter Pre-Operational (change over to "Pre-Operational")
- 5 Stop Remote Node (stop the CAN node)
- 6 Start Remote Node (start the CAN node)
- 7 Enter Pre-Operational (change over to "Pre-Operational")
- 8 Stop Remote Node (stop the CAN node)
- 9 Reset Node (reset the complete CAN node)
- 10 Reset Node (reset the complete CAN node)
- 11 Reset Node (reset the complete CAN node)
- 12 Reset Communication (reset communication for the CAN node)
- 13 Reset Communication (reset communication for the CAN node)
- 14 Reset Communication (reset communication for the CAN node)

The following messages are exchanged in the states mentioned:

- Operational: PDO and SDO communication
- Pre-Operational: only SDO-communication

The services listed above (1 to 14) are required by CANopen or performed independently by the nodes in order to change from one state to another.

The "Stopped" state can be skipped when using Minimum Boot-up.

- 1 Power-on (automatic change of state to the "Initialization" condition)
- 2 Initialization finished (automatic change of state to "Pre-Operational")
- 3, 6 Start Remote Node (start the CAN node)

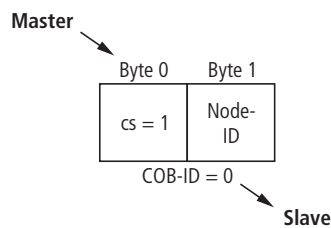

The internal change of state of the CANopen slave now requires a **pause of at least 20 ms**, before another request may be made by the master.

15, 7 Enter Pre-Operational (change over to "Pre-Operational")

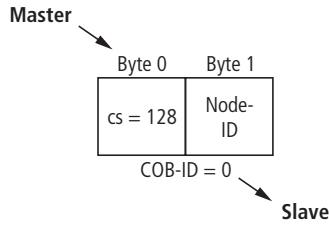

The internal change of state of the CANopen slave now requires a **pause of at least 20 ms**, before another request may be made by the master.

15, 8 Stop Remote Node (stop the CAN node)

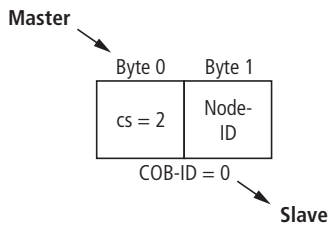

The internal change of state of the CANopen slave now requires a **pause of at least 20 ms**, before another request may be made by the master.

15, 10, 11 Reset Node (reset the complete CAN node)

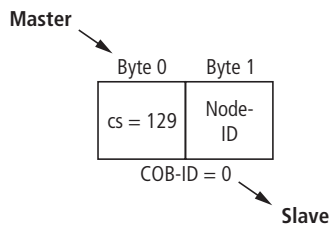

The execution of this command is confirmed by a boot-up message. This is in the form of a guard frame with the data contents 00_{hex}.

15, 13, 14 Reset Communication (reset communication for the CAN node)

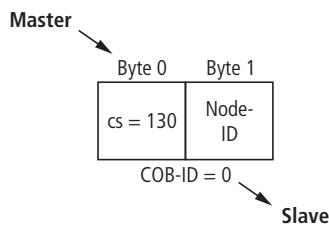

The execution of this command is confirmed by a boot-up message. This is in the form of a guard frame with the data contents 00_{hex}.

Identifier for the Standard Objects

Node-ID

The identifier for each device in a CANopen network is the Node-ID. The CANopen slaves can be assigned the Node-IDs 1 to 127. The maximum number of Node-IDs to be set may vary depending on the BLxx-product.

COB-ID (Communication Object Identifier)

The identifier for each communication object in a CANopen network is the COB-ID. The COB-IDs for the standard objects (digital input, digital output, analog input, analog output) are assigned automatically. The ranges for the COB-IDs are defined by the "Predefined Master-Slave Connection Set".

Each range for the COB-IDs has 127 numerical values.

The COB-IDs are calculated according to the following rule:

COB-ID = Base-ID + Node-ID

Base-ID: 128; 384; 512; 640; 768; 896; 1024; 1152; 1280; 1408; 1536; 1792

Node-ID: max. 1 to 127

Table 2:
Identifiers for
basic objects

COB-ID		Function	Application
dec.	hex*		
0	000 _{hex}	Network Management (NMT)	Broadcast object
01 to 127	001 _{hex} to 07F _{hex}	free	
128	080 _{hex}	Synchronization (Sync)	Broadcast object
129 to 255	081 _{hex} to 0FF _{hex}	Emergency Message	
256	100 _{hex}	Timestamp	Broadcast object
257 to 384	101 _{hex} to 180 _{hex}	free	
385 to 511	181 _{hex} to 1FF _{hex}	Transmit PDO 1	Digital input
512	200 _{hex}	free	
513 to 639	201 _{hex} to 27F _{hex}	Receive PDO 1	Digital output
640	280 _{hex}	free	
641 to 767	281 _{hex} to 2FF _{hex}	Transmit PDO 2	Analog input
768	300 _{hex}	free	
769 to 895	301 _{hex} to 37F _{hex}	Receive PDO 2	Analog output
896	380 _{hex}	free	
897 to 1023	381 _{hex} to 3FF _{hex}	Transmit PDO 3	Analog input
1024	400 _{hex}	free	
1025 to 1151	401 _{hex} to 47F _{hex}	Receive PDO 3	Analog output
1152	480 _{hex}	free	
1153 to 1279	481 _{hex} to 4FF _{hex}	Transmit PDO 4	Analog input
1280	500 _{hex}	free	

*Table 2:
Identifiers for
basic objects*

COB-ID		Function	Application
dec.	hex*		
1281 to 1407	501 _{hex} to 57F _{hex}	Receive PDO 4	Analog output
1408	580 _{hex}	free	
1409 to 1535	581 _{hex} to 5FF _{hex}	Transmit SDO	
1536	600 _{hex}	free	
1537 to 1663	601 _{hex} to 67F _{hex}	Receive SDO	
1664 to 1772	680 _{hex} to 6EC _{hex}	free	
1793 to 1919	701 _{hex} to 77F _{hex}	NMT Error (Node Guarding, Heartbeat, Boot-Up)	
1920 to 2014	800 _{hex} to 7DE _{hex}	free	
2015 to 2031	7DF _{hex} to 7EF _{hex}	NMT, LMT, DBT	

Set up Node Guarding Protocol



Note

Further information on Node Guarding can be found in CiA DS-301.

Node Guarding is the name for the monitoring of network nodes by a network manager. You distinguish between active and passive Node Guarding.

In addition, the CANopen network nodes check that their network manager is operating correctly and that the network is functioning reliably.

In the default state, Node Guarding is inactive.

Active Node Guarding

To activate the Node Guarding protocol for a node, various parameters must be set for the Object Dictionary:

- [100C] = Guard time
Given in milliseconds; the query interval (polling) that is to be expected by the network slave.
Default = 0
- [100D] = Lifetime factor
This factor, multiplied by the Guard time, is the time that should elapse after a Node Guarding protocol error before the network slave generates an error message via EMCY. In this way, a temporary communication problem, such as may be caused by heavy bus loading, can be bridged without a Guarding Error.
Default = 0
- Guard-ID
This is fixed and cannot be changed.

Guarding is initiated with the first Guard-Remote frame (Guarding-RTR) from the CANopen network manager.

The Guarding Frame of the network manager has the COBID "1793 - 1 + Node-ID" and does **not** have a data field.

Furthermore, the RTR bit in the message header must be set and the Data Length code = 1.

The node answers the telegram sent out by the network manager within the preset time (Guard time) in the "Operational" state, with the data contents **5**. The gateway answers the next polling query with the contents **133**. The following response from the gateway is with **5** again, and so on. This means that the gateway changes the state of the most significant bit after every query (i.e. the bit is toggled). If the node is in the "Pre-Operational" state, then the value of the data contents of the response telegram toggles between 127 and 255. If the node is in the "Stop" state, the value toggles between 4 and 132.

If there is no query from the network manager within the preset time, then the gateway changes to the state "Guard Fail". If output modules are fitted in the BLxx station, then their outputs will be put into defined states, depending on the objects "Error mode output" and "Error state output", or will retain the last state that was received. Any RxPDOs that are received will still be processed and output again. If the Guarding starts up again, the gateway leaves the "Guard Fail" state, but remains in the Pre-Operational state. A "Start Node" command must be generated by the network manager in order to restart the gateway (see CiA DS-301).

Passive Node Guarding

If a Guard-Time = 0 is set (see [Object 100Chex – Guard Time \(page 4-9\)](#)), then, passive guarding is activated. This means that the gateway answers the Guard-Remote-Frames without itself starting a Guard-Timer. The gateway does not change to the Pre-Operational state.

As an alternative to Node-/Life-Guarding, the Heartbeat mechanism (see [Object 1016hex – Consumer Heartbeat Time \(page 4-13\)](#) and [Object 1017hex – Producer Heartbeat Time \(page 4-15\)](#)) newly introduced with DS301 V4.0 is supported, which, unlike Guarding, does not require Remote frames.

Boot-up Message

After initialization (after Power-On, Reset-Node and Reset-Communication), a Boot-up message as per CiA DS-301 V4.0 is sent out. This is in the form of a guard frame with the contents 00_{hex}.

Under certain circumstances, a network manager may fail to detect a short drop-out of an BL20 gateway (for example, as a result of voltage variations). This could occur under the following conditions:

- The drop-out and initialization of the gateway happen in the time between two Guarding-Frames
- The gateway was already in the Pre-Operational state beforehand
- The last state of the toggle bit was 1

If a Boot-up message is sent out after a reset or initialization, then the drop-out mentioned above will also not be missed by the network manager.

2.3.2 Parameterization through Service Data Objects (SDO)

SDO (= Service Data Object) is a confirmed CANopen service that is primarily used for parameterization and configuration of the CANopen slaves (BLxx) and less frequently for transmitting process data. "Confirmed" means that an BLxx-CANopen gateway (SDO server) that is addressed by this procedure must acknowledge it through a response. In this way, the SDO client obtains information about whether the BLxx gateway that it addressed was contacted, and whether the access was achieved without any errors (error code in the response from the SDO server). SDO access means that the contents of the Object Dictionary entries for an SDO server can be read or written, and that the settings for a BLxx station can be made in this way.

Four parallel SDO servers are supported. There are three "additional" SDOs, as well as the default SDO. As a default, these are inactive, but can be parameterized and enabled through the Object Dictionary entries 1201_{hex} to 1203_{hex}.

The communication parameters for the default SDO follow the Predefined Connection Set, and cannot be modified (see CiA DS-301, V4.01).

In the following representations of the messages, the identifier of the CANopen message that is to be sent can be found below the frame, and the contents of the data byte to be transmitted are within the frame.

The following representations use the Expedited SDO Transfer, i.e. a maximum of 4 bytes of user data can be transferred within one telegram.



Note

CANopen also offers the possibility of segmented SDO-transfer of data with data length of more than 4 bytes.

Read (Read from Object Dictionary)

Figure2:
Read (Read from
Object Dictionary)

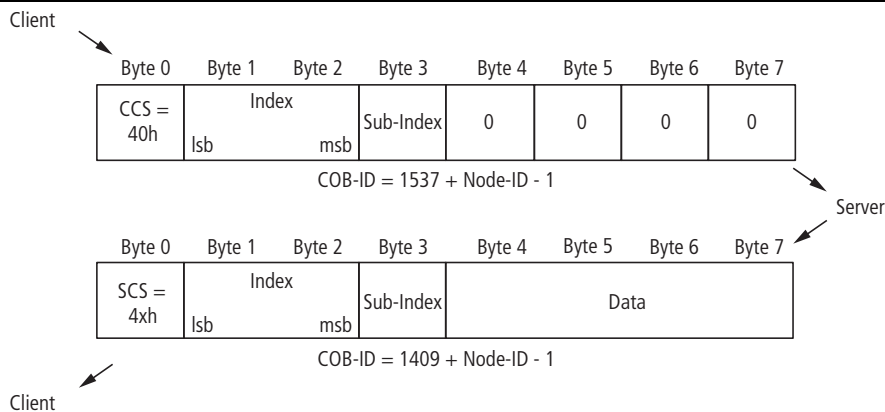

x... depending on the length of data read

LSB= Least Significant byte ? lowest value byte

MSB= Most Significant byte ? highest value byte

SCS = Server Command Specifier

CCS = Client Command Specifier

(see CiA DS-301)

The stated COB-ID refers to the default SDO server.



Note

The information in byte 0 "SCS " can optionally contain the length information for the transmitted data bytes (see CiA DS-301, Page 9-21 ff). The information in byte 0 "SCS = 4x_{hex}" means that no length information is present.

Write (Write to Object Dictionary)

Figure 3:
Write
(Write to Object Dictionary)

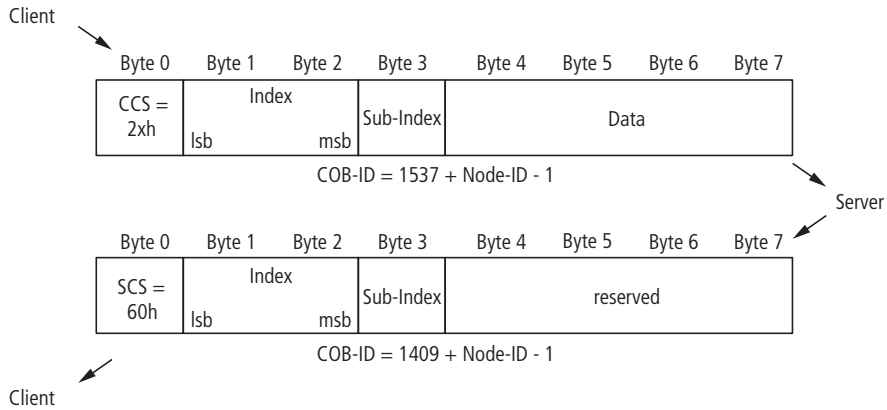

LSB= Least Significant byte ? lowest value byte

MSB= Most Significant byte ? highest value byte

SCS = Server Command Specifier

CCS = Client Command Specifier

(see CiA DS-301)

The stated COB-ID refers to the default SDO server.



Note

The information in byte 0 "SCS " can optionally contain the length information for the transmitted data bytes (see CiA DS-301). The information in byte 0 „SCS = 60h“ means that no length information is present.



Attention

If an incorrect data length is given, the error code "Abort SDO Transfer Service" will be generated (see CiA DS-301).

Table 3:
Abort codes for
errors in SDO
transfer

Abort code	Description
0503 0000 _{hex}	Toggle bit not altered.
0504 0001 _{hex}	Client server command specifier not valid or unknown.
0601 0000 _{hex}	Unsupported access to an object.
0601 0001 _{hex}	Attempt to write a read only object.
0601 0002 _{hex}	Attempt to read a write only object.
0602 0000 _{hex}	Object does not exist in the object dictionary.
06040041 _{hex}	Object cannot be mapped to the PDO.
06040042 _{hex}	The number and length of objects exceeds PDO length.

Table 3:
Abort codes for
errors in SDO
transfer

Abort code	Description
06040043 _{hex}	General parameter incompatibility reason.
06040047 _{hex}	General internal incompatibility in the device.
06070010 _{hex}	Data type does not match - wrong length.
0607 0012 _{hex}	Data type does not match- length too high.
0607 0013 _{hex}	Data type does not match- length too low.
06090011 _{hex}	Sub-index does not exist.
06090030 _{hex}	Value range of parameter exceeded.
06090031 _{hex}	Value range of parameter written too high.
06090032 _{hex}	Value range of parameter written too low
06090036 _{hex}	Maximum value is less than minimum value.
08000000 _{hex}	Other error
08000020 _{hex}	Data cannot be stored to the application.
08000021 _{hex}	Data cannot be stored to the app. because of local control.
08000022 _{hex}	Data cannot be stored to the app. because of device state.

Example:

Write a new COB-ID for RxPDO 1 (ID = 258_{hex})

Figure4:
Example COB-ID

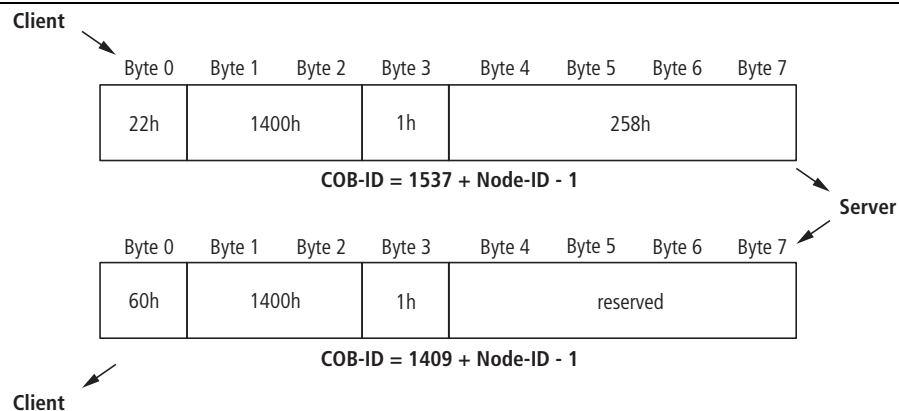

Parameter Storing/Restoring

Saving of communication and application parameters is executed by a command. This means that the parameters transferred through an SDO are held in volatile memory, until they are saved by using the command "Store parameters" (Object 1010_{hex}, Sub-indices 0 to 3). All the communication and application parameters that are supported by the gateway will be saved.

The command "Restore Default parameters" (Object 1011_{hex}, Sub-indices 0 to 3) is also supported. This command resets all the communication and/or application parameters to the default values.

2.3.3 Transmission of Process Data Objects (PDO)

PDOs are fast real-time process data that are handled as unconfirmed services without a protocol overhead.

We distinguish between:

- Transmit PDOS = TPDOs
- Receive PDOS = RPDOs

PDOs can contain a maximum of 8 bytes of data. They can be assembled and configured by the user to suit the specific requirements. In addition, there are a number of transmission/transfer settings (Transmission types) for process data.

The following attributes can be set for each PDO through the object "PDO communication parameter":

Communication parameter COB-ID

The COB-ID is the CAN identifier that is used for the transmission of a PDO (object 1800_{hex} ff and 1400_{hex} ff).

COB-IDs are used to define the priority of the message telegrams. The lowest COB-ID has the highest priority.

For communication between 2 nodes, the COB-ID of the transmit PDO must be the same as the COB-ID of the receive PDO..



Note

As delivered, each BLxx gateway has a maximum number of 8 active PDOs (0 to 8 are possible), with COB-IDs that are taken from the Predefined Master-Slave Connection Set. The compact modules of the BLCCO product line provide up to four active PDOs.

All other PDOs are inactive. This state can be seen from the invalid bit (bit 31) of the COB-ID (see also The COB-ID entries in the tables on [page 2-17 ff.](#)).

Transmission Type

The Transmission type determines under which circumstances a PDO can be transmitted or received.

The following PDO Transmission types are supported by BLxx:

- Type 0 (sync, acyclic)
- Type 1 (sync, cyclic)
- Type 253 (Remote Request)
- Type 255 (Event-Driven)

Table 4:
Overview of
PDO
Transmission
Types

Transmission Type	PDO transmission				
	cyclic	acyclic	synchr.	asynchr.	only with RTR
0		×	×		
1	×		×		
253				×	×
255				×	

Type 0

The PDO will always be transmitted (TPDO) or evaluated (RPDO) if this is permitted by a Sync-Frame transmitted by the SYNC producer and the mapped contents of the BLxx-CANopen gateway have changed since the last transmission.

Type 1

Immediately after receiving each Sync-Frame, the BLxx-CANopen gateway puts out the mapped contents as a PDO on the network, even if they have not changed since the last transmission.

Type 253

The PDO is only transmitted if a transmitted Remote-Frame requests this from the BLxx-CANopen gateway.



Attention

This Transmission Type is only allowed for TPDOs.

Type 255

In this mode of operation, the BLxx-CANopen gateway does not depend on any Sync or Remote-Request for PDO communication. Whenever this is envisaged for an internal event within the BLxxCANopen gateway, the gateway will transmit a PDO to the CANopen network.

The Transmission types of the individual PDOs are independent, which means that a freely mixed operation with synchronous and asynchronous PDOs is possible.

2.3.4 Inhibit Time

The setting of an Inhibit time for the PDOs (Object 1800_{hex} ff, Sub-Index 03_{hex}) is only supported for TPDOs. Unlike the other time values, which are given as multiples of 1 ms, the Inhibit time is defined as a multiple of 100 μs . However, since the time resolution of the system clock in the BLxx-CANopen gateway is 1 ms, Inhibit time values below $10 \times 100 \mu\text{s}$ are pointless.

2.3.5 Event Timer

The Event timer (Object 1800_{hex} ff, Sub-Index 05_{hex}) defines the maximum interval after which a TPDO will be transmitted, even though no event has occurred. This means that the Event timer determines the maximum interval between two transmissions of a TPDO.

The expiry of the interval set for the Event timer is detected as an event. If any other event occurs, the Event timer is reset and restarted.

The value of the object is interpreted as a multiple of 1 ms.

Available PDOs

BLxx:

64 PDOs are supported:

- 32 Transmit-PDOs: TPDO1 to TPDO32 (Index 1800_{hex} to $181F_{\text{hex}}$)
- 32 Receive-PDOs: RPDO1 to RPDO32 (Index 1400_{hex} to $141F_{\text{hex}}$)

BLCCO:

8 PDOs are supported:

- 4 Transmit-PDOs: TPDO1 to TPDO4 (Index 1800_{hex} to 1803_{hex})
- 4 Receive-PDOs: RPDO1 to RPDO4 (Index 1400_{hex} to 1403_{hex})

The corresponding Default Master-Slave Connection Set is supported for each of the PDOs 1 to 4, so that a COB-ID distribution is not necessary for these PDOs.

If one of the COB-IDs from xPDO1 to xPDO4 is reconfigured, then the use of a COB-ID from the Default Master-Slave Connection Set can be achieved by setting this COB-ID to 0.

2.3.6 Mapping Objects in PDOs

Mapping is the assignment of objects from an Object Dictionary in a PDO for transmission/reception through the CAN-bus. More than one object can be transmitted in a single PDO.

The Mapping parameters determine which items of information are transmitted in a PDO:

Table 5:
Object
Dictionary for
mapping
parameters

	PDO		Object Dictionary entries
	Type	Product family	Range
Transmit-PDOs	BL20/BL67	TPDO1 to TPDO32	$1A00_{\text{hex}}$ to $1A1F_{\text{hex}}$
	BLCCO	TPDO1 to TPDO4	$1A00_{\text{hex}}$ to $1A03_{\text{hex}}$
Receive-PDOs	BL20/BL67	RPDO1 to RPDO32	1600_{hex} to $161F_{\text{hex}}$
	BLCCO	RPDO1 to RPDO4	1600_{hex} to 1603_{hex}

Default-PDOs and PDO-mappings

The 4 Transmit and 4 Receive-PDOs which are specified by the Communication Profile CiA DS-301 are supported by BLxx. The mapping of these PDOs and their Transmission types are specified by the I/O-Device Profile CiA DS-401.



Note

BL67/BL20:

The Default-PDOs are only activated if the planned objects and sub-indices actually exist for the corresponding PDO. If, in a station, for example no analog I/Os are used, then the PDOs 2 to 4 are set to "Invalid" and no mapping entries will be present.

In addition to the default PDOs which are standardized by the CiA DS-301 and DS-401 profiles, other PDOs for a -CANopen gateway may be provided with mapping entries and communication parameters.

These additional PDOs (5 to 16) will be set to "Invalid" as a default (see [Table 6: Overview Default-TPDOs as per CiA DS-301 und DS-401](#) to [Table 9: Overview of the BLxx-specific Default-RPDOs](#)).

Default-PDOs as per CiA DS-301 und DS-401

The TPDOs in the following table have the following characteristics:

- The COB-ID is part of sub-index 01_{hex}
- The PDO is active!
The first digit of the 8-digit hexadecimal COB-ID-number shows amongst others, if the PDO is valid. Active PDOs are marked by a hex-digit 7. Normally, the digit is 0 or 4. → [Description of the COB-ID entry \(sub-index 01hex\)](#) (page 4-29).

Overview of the Default-TPDOs as per CiA DS-301 and DS-401

Table 6:
Overview
Default-TPDOs
as per CiA DS-
301 und DS-401

Meaning	TPDO	Sub-Index 01 _{hex} - "COB-ID"
1 group, digital input channels, (bits 0 to 63)	PDO1 1800 _{hex}	0000 0180 _{hex} + Node-ID
1 group, analog input channels, (channels 0 to 3)	PDO2 1801 _{hex}	0000 0280 _{hex} + Node-ID
2 group, analog input channels, (channels 4 to 7)	PDO3 1802 _{hex}	0000 0380 _{hex} + Node-ID
3 group, analog input channels, (channels 8 to 11)	PDO4 1803 _{hex}	0000 0480 _{hex} + Node-ID

Overview of the Default-RPDOs as per CiA DS-301 and DS-401

Table 7:
Overview
Default-RPDOs
as per CiA DS-
301 und DS-401

Meaning	RPDO	COB-ID
1 group, digital output channels, (bits 0 to 63)	PDO1 1400 _{hex}	0000 0200 _{hex} + Node-ID
1 group, analog output channels, (channels 0 to 3)	PDO2 1401 _{hex}	0000 0300 _{hex} + Node-ID
2 group, analog output channels, (channels 4 to 7)	PDO3 1402 _{hex}	0000 0400 _{hex} + Node-ID
3 group, analog output channels, (channels 8 to 11)	PDO4 1403 _{hex}	0000 0500 _{hex} + Node-ID

BLxx-spezifische Default-PDOs (gilt nicht für BL compact)

These additional PDOs will be set to "Invalid" as a default.

Before enabling these PDOs, the corresponding parameters must be checked. This applies especially to the COB-IDs, since these are taken from the Default Master-Slave Connection Set, and are assigned to other Node-IDs. For this reason, other nodes with the corresponding Node-ID must not be present in the network, or such nodes must not use the corresponding COB-IDs.

The Transmission type of these PDOs is generally 255.

Overview of the BLxx-specific Default-TPDOs (not valid for BL compact)



Note

The COB-ID definition for the TPDOs depends on the gateway used in the application (see EDS file for the gateways).

Table 8:
Overview of the
BLxx-specific
Default-TPDOs

		BL20- -GW-CO	BL67-GW-CO/ BL20-GWBR-CANopen
Meaning	TPDOs	COB-ID TPDO	COB-ID TPDO
2 group digital input channels (bits 64 to 127)	PDO5 1804 _{hex}	8000 01C0 _{hex} + Node-ID	8000 01C0 _{hex} + Node-ID
3 group digital input channels (bits 128 to 191)	PDO6 1805 _{hex}	8000 02C0 _{hex} + Node-ID	8000 02C0 _{hex} + Node-ID
4 group digital input channels (bits 192 to 255)	PDO7 1806 _{hex}	8000 03C0 _{hex} + Node-ID	C000 03C0 _{hex} + Node-ID
5 group digital input channels (bits 256 to 319)	PDO8 1807 _{hex}	8000 04C0 _{hex} + Node-ID	C000 04C0 _{hex} + Node-ID
1 group encoders (channels 0 +1)	PDO9 1808 _{hex}	8000 01E0 _{hex} + Node-ID	C000 01E0 _{hex} + Node-ID
2 group encoders (channels 2 3)	PDO10 1809 _{hex}	8000 02E0 _{hex} + Node-ID	C000 02E0 _{hex} + Node-ID
3 group encoders (channels 4 5)	PDO11 180A _{hex}	8000 03E0 _{hex} + Node-ID	C000 03E0 _{hex} + Node-ID
4 group encoders (channels 6 7)	PDO12 180B _{hex}	8000 04E0 _{hex} + Node-ID	C000 04E0 _{hex} + Node-ID
4 group analog input channels (channels 12 to 15)	PDO13 180C _{hex}	8000 01A0 _{hex} + Node-ID	C000 01A0 _{hex} + Node-ID
5 group analog input channels (channels 16 to 19)	PDO14 180D _{hex}	8000 02A0 _{hex} + Node-ID	C000 02A0 _{hex} + Node-ID
6 group analog input channels (channels 20 to 23)	PDO15 180E _{hex}	88000 000 03A0 _{hex} + Node-ID	C8000 000 03A0 _{hex} + Node-ID
7 group analog input channels (channels 24 to 27)	PDO16 180F _{hex}	8000 04A0 _{hex} + Node-ID	C000 04A0 _{hex} + Node-ID
1. group RSxx (channel 0)	PDO18 1811 _{hex}	8000 0000 _{hex}	C000 0000 _{hex}
1. group RSxx (channel 1)	PDO19 1812 _{hex}	8000 0000 _{hex}	C000 0000 _{hex}

Overview of the BLxx-specific Default-TPDOs (not valid for BL compact)

Table 9:
Overview of the
BLxx-specific
Default-RPDOs

Meaning	RPDOs	COB-ID RPDO
2 group, digital input I/Os, (bits 64 to 127)	PDO5 1404 _{hex}	8000 0240 _{hex} + Node-ID
3 group, digital input I/Os, (bits 128 to 191)	PDO6 1405 _{hex}	8000 0340 _{hex} + Node-ID
4 group, digital input I/Os, (bits 192 to 255)	PDO7 1406 _{hex}	8000 0440 _{hex} + Node-ID
5 group, digital input I/Os, (bits 256 to 319)	PDO8 1407 _{hex}	8000 0540 _{hex} + Node-ID
1 group encoders (channel 0 + 1)	PDO9 1408 _{hex}	8000 0260 _{hex} + Node-ID
2 group encoders (channel 2 + 3)	PDO10 1409 _{hex}	8000 0360 _{hex} + Node-ID
3 group encoders (channel 4 + 5)	PDO11 140A _{hex}	8000 0460 _{hex} + Node-ID
4 group encoders (channel 6 + 7)	PDO12 140B _{hex}	8000 0560 _{hex} + Node-ID
4 group analog I/Os, (channels 12 to 15)	PDO13 140C _{hex}	8000 0220 _{hex} + Node-ID
5 group analog I/Os, (channels 16 to 19)	PDO14 140D _{hex}	8000 0320 _{hex} + Node-ID
6 group analog I/Os, (channels 20 to 23)	PDO15 140E _{hex}	8000 0420 _{hex} + Node-ID
7 group analog I/Os, (channels 24 to 27)	PDO16 140F _{hex}	8000 0520 _{hex} + Node-ID
1. group RSxx (channel 0)	PDO18 1411 _{hex}	8000 0000 _{hex}
1. group RSxx (channel 1)	PDO19 1412 _{hex}	8000 0000 _{hex}

**Attention**

The COB-ID for the RSxxx-Module must be defined by the user!

Example (not valid for BLCCO)

The own Node-ID of an BLxx-CANopen gateway is 1. There are more than 12 analog input channels. As a result, appropriate mapping entries are set up for TPDO13 (Object 1A0C_{hex}), and the COB-ID (Object 180C, Sub-Index 1) is pre-loaded with the value 8000 01A1_{hex}. This PDO can only be enabled without alteration if a node with the Node-ID 33 (own Node-ID + 32) does not exist, or at least its TPDO1 is not used.+

The following table illustrates the systematic relationship:

<i>Table 10: Relationship between a Node-ID and BL20-specific PDOs</i>	PDO	Node-ID assigned to this COB-ID in the Default Master-Slave Connection Set	Original PDO assigned to this COB-ID in the Default Master-Slave Connection Set
	PDO5	own Node-ID + 64 (40 _{hex})	PDO1
	PDO6	own Node-ID + 64 (40 _{hex})	PDO2
	PDO7	own Node-ID + 64 (40 _{hex})	PDO3
	PDO8	own Node-ID + 64 (40 _{hex})	PDO4
	PDO9	own Node-ID + 96 (60 _{hex})	PDO1
	PDO10	own Node-ID + 96 (60 _{hex})	PDO2
	PDO11	own Node-ID + 96 (60 _{hex})	PDO3
	PDO12	own Node-ID + 96 (60 _{hex})	PDO4
	PDO13	own Node-ID + 32 (20 _{hex})	PDO1
	PDO14	own Node-ID + 32 (20 _{hex})	PDO2
	PDO15	own Node-ID + 32 (20 _{hex})	PDO3
	PDO16	own Node-ID + 32 (20 _{hex})	PDO4

Mappable Objects

The maximum of 64 mapping entries per PDO that is specified by Communication Profile CiA DS-301 is supported.

The following objects from the Object Dictionary can be mapped:

Table 11: Overview of mappable objects

A"n" depends on the used object as well as on the used product

Name	Index	Sub-index	Direction
Dummy Mapping Boolean	0001 _{hex}	-	Receive
Dummy Mapping Boolean Integer8	0002 _{hex}	-	Receive
Dummy Mapping Boolean Integer16	0003 _{hex}	-	Receive
Dummy Mapping Boolean Integer32	0004 _{hex}	-	Receive
Dummy Mapping Boolean Unsigned8	0005 _{hex}	-	Receive
Dummy Mapping Boolean Unsigned16	0006 _{hex}	-	Receive
Dummy Mapping Boolean Unsigned32	0007 _{hex}	-	Receive
Error register	1001 _{hex}	-	Transmit
Manu Spec Analog Input Range	5420 _{hex}	1 to n A	Transmit
RS232/RS4xx RxD	5601 _{hex}	1 to n	Receive
RS232/RS4xx TxD	5602 _{hex}	1 to n	Transmit
RFID Input Data U64	5700	1 to n	
RFID Output Data U64	5702	1 to n	
RFID Status	5708	1 to n	
Encoder Status	5802 _{hex}	1 to n	Transmit
Encoder Flags	5803 _{hex}	1 to n	Transmit
SSI Native Status	5805 _{hex}	1 to n	Transmit
SSI Optional Encoder Status	5806 _{hex}	1 to n	Transmit
Encoder Control	5808 _{hex}	1 to n	Receive
PwmStatus	5902 _{hex}	1 to n	
PwmFlags	5903 _{hex}	1 to n	
PwmControl	5908 _{hex}	1 to n	
PwmPeriodDuration	5920 _{hex}	1 to n	
Read Input 8 Bit	6000 _{hex}	1 to n	Transmit
Read Input Bit (1 to 128) A	6020 _{hex}	1 to n	Transmit
Read Input Bit (129 to 256)	6021 _{hex}	1 to n	Transmit
Read Input Bit (257 to 288)	6022 _{hex}	1 to n	Transmit

Table 11:
Overview of
mappable
objects

Name	Index	Sub-index	Direction
Read Input 16 Bit	6100 _{hex}	1 to n	Transmit
Read Input 32 Bit	6120 _{hex}	1 to n	Transmit
Write Output 8 Bit	6200 _{hex}	1 to n	Receive
Write Output Bit (1 to 128) A	6220 _{hex}	1 to n	Receive
Write Output Bit (129 to 256) A	6221 _{hex}	1 to n	Receive
Write Output Bit (257 to 288)	6222 _{hex}	1 to n	Receive
Write Output 16 Bit	6300 _{hex}	1 to n	Receive
Write Output 32 Bit	6320 _{hex}	1 to n	Receive
Read Analog Input 16 Bit	6401 _{hex}	1 to n	Transmit
Write Analog Output 16 Bit	6411 _{hex}	1 to n	Receive
Preset Value for Multi-Sensor Devices	6810 _{hex}	1 to n	Transmit
Position Value for Multi-Sensor Devices	6820 _{hex}	1 to n	Transmit
CAM1 State Register	6B00 _{hex}	1 to n	Transmit
Area State Register	6C00 _{hex}	1 to n	Transmit

Procedure for Altering PDO-Mappings

The Communication Profile CiA DS-301 Version 4 defines a detailed procedure for altering PDO-mappings.

For the gateway, this results in the following method for modifying PDO-mappings:

- The node state of the gateway must be "Pre-Operational".
- The number of mapping entries (Sub-index 0) for a PDO must be set to 0.
- The mapping entries (Sub-index 1 to 64) can be written.
- The number of mapping entries (Sub-index 0) must now be set to the valid number of mapped objects.
- Alternatively, the new mapping can be saved in non-volatile memory (Store Communication parameters).

The following abort codes (Abort-Domain-Protocol) may be sent back by the gateway in case of an error:

Table 12:
Abort code

Abort code	Description as per CiA DS-301	Possible cause
0604 0041 _{hex}	Object cannot be mapped	Invalid object-index transferred while writing the mapping entries.
0604 0042 _{hex}	Number or length of the objects exceeds the PDO length	Attempted to map too many or excessively long objects to a PDO. This will be returned on writing to the sub-index 0.

Table 12:
Abort code

Abort code	Description as per CiA DS-301	Possible cause
0609 0011 _{hex}	Sub-index does not exist.	A sub-index > 64 was addressed.
0800 0022 _{hex}	Access not possible in this node state	Write access is only possible in the "Pre-operational" node state. Write access to Sub-indices 1 to 64 is only possible if sub-index 0 is written with value 0.

2.3.7 Commands for "Parameter Save" and "Restore Defaults"

Parameter changes that are made through SDO access are only stored in volatile memory. All alterations that are made by the user will be replaced by default values at the next Reset Communication, Reset Node or Power-ON-Boot-Up.

With BL××0, it is possible to use a command to make a permanent save of the communication and/or application parameters. This is done through the "Store parameters" command (Object 1010_{hex} sub-index 1 to 3).

The command is executed by using an SDO to write the data contents 6576 6173_{hex} ("save") to one of the following entries:

- 1010_{hex} sub-index 1 saves all parameters
- 1010_{hex} sub-index 2 saves all parameters
- 1010_{hex} sub-index 3 saves all device parameters (see CiA DS-301 V4.01)

Table 13:
Data contents
0x6576 6173
(„save“)

	MSB		LSB	
ASCII	e	v	a	s
hex	65 _{hex}	76 _{hex}	61 _{hex}	73 _{hex}

Since in some circumstances it may not be possible to restore the original memory contents after a lot of alterations, BL×× supports the "Restore default Parameter" command (Object 1011_{hex} sub-index 1 to 3) with the following data contents: 6461 6F6C_{hex} ("load").

Table 14:
Data contents
0x6461 6F6C
(„load“)

	MSB		LSB	
ASCII	d	a	o	l
hex	64 _{hex}	61 _{hex}	6F _{hex}	6C _{hex}

The division of the Sub-entries corresponds to that for the "Store parameters" command.

After the command "Restore default parameters", a Reset Node must be carried out, followed by a "Store parameters" command. The default values are only saved again when this last command is executed.

3 Object dictionary - overview of all objects

3.1 Overview of all objects..... 2

3.1 Overview of all objects

The following table provides an overview of all objects supported by the BLxx-CANopen gateway.

Table 15:
Overview of all
objects

Index	Name	BLxx-GWBR-CANOPEN	B67-GW-CANOPEN	BLxx-E-GW-CO	BLCCO-xxx
Objects (according to CiA CS-301)					
1000 _{hex}	Device Type	X	X	X	X
1001 _{hex}	Error register	X	X	X	X
1005 _{hex}	SYNC COB-ID	X	X	X	X
1008 _{hex}	Device Name	X	X	X	X
1009 _{hex}	Manufacturer Hardware Version	X	X	X	X
100A _{hex}	Manufacturer Software Version	X	X	X	X
100C _{hex}	Guard Time	X	X	X	X
100D _{hex}	Lifetime Factor	X	X	X	X
1010 _{hex}	Store Parameters	X	X	X	X
1011 _{hex}	Restore Default Parameters	X	X	X	X
1014 _{hex}	Emcy COB-ID	X	X	X	X
1016 _{hex}	Consumer Heartbeat Time	X	X	X	X
1017 _{hex}	Producer Heartbeat Time	X	X	X	X
1018 _{hex}	Identity Object	X	X	X	X
1020 _{hex}	Verify Configuration	X	X	X	X
1027 _{hex}	Module List	X	X	X	
1200 _{hex} to 1203 _{hex}	Server SDO Parameters	X	X	X	X
1400 _{hex} to 1403 _{hex}	Receive PDO Communication Parameters (1 to 4)	X	X	X	X
1404 _{hex} to 141F _{hex}	Receive PDO Communication Parameters (5 to 32)	X	X	X	
1600 _{hex} to 1603 _{hex}	Receive PDO-Mapping Parameters (1 to 4)	X	X	X	X
1604 _{hex} to 161F _{hex}	Receive PDO-Mapping Parameters (5 to 32)	X	X	X	

see [Kapitel 4](#)

Table 15:
Overview of all
objects

Index	Name	BLxx-GWBR-CANOPEN	B67-GW-CANOPEN	BLxx-E-GW-CO	BLCCO-xxx	
1800 _{hex} to 1803 _{hex}	Transmit PDO-Parameters (1 to 4)	X	X	X	X	see Kapitel 4
1800 _{hex} to 181F _{hex}	Transmit PDO-Parameters (5 to 32)	X	X	X		
1A00 _{hex} to 1A03 _{hex}	Transmit PDO-Mapping Parameters (1 to 4)	X	X	X	X	
1A04 _{hex} to 1A1F _{hex}	Transmit PDO-Mapping Parameters (5 to 32)	X	X	X		
1F80 _{hex}	NMT Startup	X	X	X		
1F81 _{hex}	Slave Assignment	X	X	X		
1F82 _{hex'}	Request NMT	X	X	X		
1F83 _{hex}	Request Guarding	X	X	X		
Manufacturer specific objects						
2000 _{hex}	Serial Number	X	X	X	X	
2010 _{hex}	Node Reset Modifiers	X	X	X	X	
2400 _{hex}	System Voltages		X			
2401 _{hex}	System Voltages		X			
3000 _{hex}	XBIInputByte	X	X	X	X	see Kapitel 14
3002 _{hex}	XBIInputWord	X	X	X	X	
3004 _{hex} to 300B _{hex}	XBIInputDWord0 to XBIInputDWord8	X	X	X	X	
3020 _{hex}	XBIOutputByte	X	X	X	X	
3022 _{hex}	XBIOutputByte	X	X	X	X	
3024 _{hex} to 302B _{hex}	XBIOutputDWord0 to XBIOutputDWord8	X	X	X	X	
3040 _{hex}	XBIDiagByte	X	X	X	X	
3042 _{hex}	XBIDiagWord	X	X	X	X	
3044 _{hex} to 304B _{hex}	XBIDiagDWord0 to XBIDiagDWord8	X	X	X	X	
3060 _{hex}	XBIParamByte	X	X	X	X	

Object dictionary - overview of all objects

Table 15:
Overview of all
objects

Index	Name	BLxx-GWBR-CANOPEN	B67-GW-CANOPEN	BLxx-E-GW-CO	BLCCO-xxx	
3062 _{hex}	XBIParamWord	X	X	X	X	see Kapitel 14
3064 _{hex} to 306B _{hex}	XBIParamDWord0 to XBIParamDWord8	X	X	X	X	
3081 _{hex}	XBIReferenceModuleType	X	X	X	X	
3084 _{hex}	XBIReferenceInputSize	X	X	X	X	
3085 _{hex}	XBIReferenceOutputSize	X	X	X	X	
3086 _{hex}	XBIReferenceDiagSize	X	X	X	X	
3087 _{hex}	XBIReferenceParamSize	X	X	X	X	
3090 _{hex}	XBICurrentModuleId	X	X	X	X	
3091 _{hex}	XBICurrentModuleType	X	X	X	X	
3094 _{hex}	XBICurrentInputSize	X	X	X	X	
3095 _{hex}	XBICurrentOutputSize	X	X	X	X	
3096 _{hex}	XBICurrentDiagSize	X	X	X	X	
3097 _{hex}	XBICurrentParamSize	X	X	X	X	
5420 _{hex}	Analog Input Mode	X	X	X	X	see Kapitel 8
5440 _{hex}	Analog Output Mode	X	X	X	X	see Kapitel 9
5600 _{hex}	RS232/RS4xx parameters	X	X	X	X	see Kapitel 10
5601 _{hex}	RS232/RS4xx RxD	X	X	X	X	
5602 _{hex}	RS232/RS4xx TxD	X	X	X	X	
5801 _{hex}	Encoder Config	X	X	X	X	see Kapitel 11
5802 _{hex}	Encoder Status	X	X	X	X	
5803 _{hex}	Encoder Flags	X	X	X	X	
5804 _{hex}	Encoder Diag	X	X	X	X	
5805 _{hex}	Encoder Native Status	X	X	X	X	
5806 _{hex}	Encoder Optional Encoder	X	X	X	X	
5808 _{hex}	Encoder Control	X	X	X	X	
5810 _{hex}	Encoder Load Prepare Value	X		X		

Table 15:
Overview of all
objects

Index	Name	BLxx-GWBR-CANOPEN	B67-GW-CANOPEN	BLxx-E-GW-CO	BLCCO-xxx	
5811 _{hex}	Encoder Pulse Width	X		X		see Kapitel 11
5820 _{hex}	Measuring Integration Time	X		X		
5821 _{hex}	Measuring Low Limit					
5822 _{hex}	Measuring High Limit					
5823 _{hex}	Measuring Units Per Revolution					
5824 _{hex}	Encoder Measuring Divisor	X		X		
5825 _{hex}	Encoder Measuring Factor	X		X		
5827 _{hex}	Encoder Measuring Time Out	X		X		
5830 _{hex}	Encoder Measuring Value	X		X		
5831 _{hex}	Encoder Latch Value	X		X		
5840 _{hex}	SSI Diag Mapping	X	X	X		
5901 _{hex}	PWM Config	X		X		
5902 _{hex}	PWM Status	X		X		
5903 _{hex}	PWM Flags	X		X		
5904 _{hex}	PWM Diag	X		X		
5908 _{hex}	PWM Control	X		X		
5910 _{hex}	PWM Load Prepare Value	X		X		
5913 _{hex}	PWM Duty Cycle	X		X		
5920 _{hex}	PWM Period Duration	X		X		
5931 _{hex}	PWM Latch Value	X		X		
I/O module objects (according to CiA CS-401)						
6000 _{hex}	Read Input 8 Bit	X	X	X	X	see Kapitel 5 and Kapitel 7
6020 _{hex}	Read Input Bit 1 to 128	X	X	X	X	
6021 _{hex}	Read Input Bit 129 to 256	X	X	X	X	
6022 _{hex}	Read Input Bit 257 to 288	X	X	X	X	
6100 _{hex}	Read Input 16 Bit	X	X	X	X	
6120 _{hex}	Read Input 32 Bit	X	X	X	X	

Table 15:
Overview of all
objects

Index	Name	BLxx-GWBR-CANOPEN	B67-GW-CANOPEN	BLxx-E-GW-CO	BLCCO-xxx	
6200 _{hex}	Write Output 8 Bit	X	X	X	X	see Kapitel 6 and Kapitel 7
6206 _{hex}	Error Mode Output 8 Bit	X	X	X	X	
6207 _{hex}	Error Value Output 8 Bit	X	X	X	X	
6220 _{hex} to 6222 _{hex}	Write Output Bit 1 to 128 to Write Output Bit 257 to 288	X	X	X	X	
6250 _{hex} to 6252 _{hex}	Error Mode Output Bit 1 to 128 to Error Mode Output Bit 257 to 288	X	X	X	X	
6260 _{hex} to 6262 _{hex}	Error Value Output Bit 1 to 128 to Error Value Output Bit 257 to 288	X	X	X	X	see Kapitel 6
6300 _{hex}	Write Output 16 Bit	X	X	X	X	
6306 _{hex}	Error Mode Output 16 Bit	X	X	X	X	
6307 _{hex}	Error Value Output 16 Bit	X	X	X	X	
6320 _{hex}	Write Output 32 Bit	X	X	X	X	
6326 _{hex}	Error Mode Output 32 Bit	X	X	X	X	
6327 _{hex}	Error Value Output 32 Bit	X	X	X	X	
6401 _{hex}	Read Analog Input 16 Bit	X	X	X	X	see Kapitel 8
6411 _{hex}	Write Analog Output 16 Bit	X	X	X	X	see Kapitel 9
6421 _{hex}	Analog Input Interrupt Trigger Auswahl	X	X	X	X	see Kapitel 8
6422 _{hex}	Analog Input Interrupt Source	X	X	X	X	
6423 _{hex}	Analog Input global Interrupt Enable	X	X	X	X	
6424 _{hex}	Analog Input Interrupt Upper Limit Integer	X	X	X	X	
6425 _{hex}	Analog Input Interrupt lower Limit Integer	X	X	X	X	
6426 _{hex}	Analog Input Interrupt Delta Unsigned	X	X	X	X	
6427 _{hex}	Analog Input Interrupt Negative Delta Unsigned	X	X	X	X	
6428 _{hex}	Analog Input Interrupt Positive Delta Unsigned	X	X	X	X	

Table 15:
Overview of all
objects

Index	Name	BLxx-GWBR-CANOPEN	B67-GW-CANOPEN	BLxx-E-GW-CO	BLCCO-xxx	
6443 _{hex}	Analog Output Error Mode	X	X	X	X	see Kapitel 9
6444 _{hex}	Analog Output Error Value Integer	X	X	X	X	
67FF _{hex}	Device Type	X	X	X	X	see Kapitel 4
I/O module objects (according to CiA DS-406)						
6800 _{hex}	Operating parameters	X	X	X	X	see Kapitel 11
6810 _{hex}	Preset Value for Multi-Sensor Devices	X	X	X	X	
6820 _{hex}	Position Value for Multi-Sensor Devices	X	X	X	X	
6B00 _{hex}	CAM State Register	X	X	X	X	
6B00 _{hex}	CAM Enable Register	X	X	X	X	
6B00 _{hex}	CAM Polarity Register	X	X	X	X	
6B10 _{hex}	CAM1 Low Limit	X	X	X	X	
6B20 _{hex}	CAM1 High Limit	X	X	X	X	
67FF _{hex}	Device TypeDS401	X	X	X	X	
6FFF _{hex}	Device TypeDS406	X	X	X	X	

4 Device (gateway) objects

4.1	Objects of the Communication Profile (acc. to CiA DS-301)	2
4.1.1	Object 1000 _{hex} – Device Type.....	5
4.1.2	Object 1001 _{hex} – Error Register	5
4.1.3	Object 1005 _{hex} – SYNC COB-ID	6
4.1.4	Object 1008 _{hex} – Device Name	7
4.1.5	Object 1009 _{hex} – Manufacturer Hardware Version	8
4.1.6	Object 100A _{hex} – Manufacturer Software Version	8
4.1.7	Object 100C _{hex} – Guard Time	9
4.1.8	Object 100D _{hex} – Lifetime Factor	9
4.1.9	Object 1010 _{hex} – Store Parameters.....	10
4.1.10	Object 1011 _{hex} – Restore Default Parameters	11
4.1.11	Object 1014 _{hex} – Emcy COB-ID.....	12
4.1.12	Object 1016 _{hex} – Consumer Heartbeat Time	13
4.1.13	Object 1017 _{hex} – Producer Heartbeat Time.....	15
4.1.14	Object 1018 _{hex} – Identity Object	16
4.1.15	Object 1020 _{hex} – Verify Configuration.....	17
4.1.16	Object 1027 _{hex} – Module List.....	19
4.2	Objects for the Transfer of Service Data	20
4.2.1	Objects 1200 _{hex} to 1203 _{hex} – Server SDO Default Parameters	20
4.3	Objects for the Transfer of Process Output Data	21
4.3.1	Object 1400 _{hex} to 141F _{hex} – Receive PDO Comm. Default Parameters	21
4.3.2	Object 1600 _{hex} to 161F _{hex} – Receive PDO-Mapping Parameter.....	24
4.4	Objects for the Transfer of Process Input Data	27
4.4.1	Object 1800 _{hex} to 181F _{hex} – Transmit PDO-Parameters	27
	– Inhibit time	30
	– Event Timer.....	30
4.4.2	Objects 1A00 _{hex} to 1A1F _{hex} - Transmit PDO Mapping Parameter	30
4.5	Objects for network management (not valid for BLCCO)	33
4.5.1	Object 1F80 _{hex} – NMT Start-up.....	33
4.5.2	Object 1F81 _{hex} – Slave Assignment.....	34
4.5.3	Object 1F82 _{hex} – Request NMT.....	36
4.5.4	Object 1F83 _{hex} – Request Guarding	38
4.6	Overview about the objects of the Device Profile (acc. to CiA DS-401 and 406)	39
4.6.1	Object 67FF _{hex} – Device Type.....	39
4.6.2	Object 6FFF _{hex} – Device Type.....	40
4.7	Manufacturer specific device objects	40
4.7.1	Object 2000 _{hex} – Serial Number.....	40
4.7.2	Object 2010 _{hex} – Node ResetModifiers.....	41
4.7.3	Object 2400 _{hex} - System Voltages (only BL67)	45
4.7.4	Object 2401 _{hex} - System Currents (only BL67)	45

4.1 Objects of the Communication Profile (acc. to CiA DS-301)

The following table provides an overview of the supported entries in the object directory which are defined through the Communication Profile CiA DS-301.

The column **Object** shows the object type.

The column **Name** shows the predefined symbolic name of the entry.

The column **Type** shows the entry's data type predefined in CiA DS-301.

The column **Access** shows the access options for the entry. These are:

- rw (read/write)
- ro (read only)
- const (constant) = a read-only constant

The column **M/O/C** indicates if the entry is **M**andatory, **O**ptional or **C**onditional (depending on the Device Type, e. g. modular or compact device).

Table 16:
Object over-
view for the
communication
Profile CiA
DS-301

Index (hex)	Object	Name	Type	Access	M/O/C
1000 _{hex}	VAR	Device Type (page 4-5)	Unsigned32	const	M
1001 _{hex}	ARRAY	Error Register (page 4-5)	Unsigned8	ro	M
1005 _{hex}	VAR	SYNC COB-ID (page 4-6)	Unsigned32	rw	O
1008 _{hex}	VAR	Device Name (page 4-7)	Vis-String	const	O
1009 _{hex}	VAR	Manufacturer Hardware Version (page 4-8)	Vis-String	const	O
100A _{hex}	VAR	Manufacturer Software Version (page 4-8)	Vis-String	const	O
100C _{hex}	VAR	Guard Time (page 4-9)	Unsigned32	rw	O
100D _{hex}	VAR	Lifetime Factor (page 4-9)	Unsigned32	rw	O
1010 _{hex}	ARRAY	Store Parameters (page 4-10)	Unsigned32	rw	O
1011 _{hex}	ARRAY	Restore Default Parameters (page 4-11)	Unsigned32	rw	O
1014 _{hex}	VAR	Emcy COB-ID (page 4-12)	Unsigned32	rw	O
1016 _{hex}	ARRAY	Consumer Heartbeat Time (page 4-13)	Unsigned32	rw	O
1017 _{hex}	VAR	Producer Heartbeat Time (page 4-15)	Unsigned16	rw	O
1018 _{hex}	RECORD	Identity Object (page 4-16)	Identity	ro	O
1020 _{hex}	ARRAY	Verify Configuration (page 4-17)	Unsigned32	rw	O
1027 _{hex}	ARRAY	Module List (page 4-19)	Unsigned16	ro	C

Table 16:
Object over-
view for the
communication
Profile CiA
DS-301

Index (hex)	Object	Name	Type	Access	M/O/C
Server SDO Parameter					
1200 _{hex}	RECORD	1st Server SDO Parameter (page 4-20)	SDO-Parameters	ro	O
1201 _{hex}	RECORD	2nd Server SDO Parameter (page 4-20)	SDO-parameters	rw	O
1202 _{hex}	RECORD	3rd Server SDO Parameter (page 4-20)	SDO-parameters	rw	O
1203 _{hex}	RECORD	4th Server SDO Parameter (page 4-20)	SDO-parameters	rw	O
Receive PDO Communication Parameters					
1400 _{hex}	RECORD	1st Receive PDO Parameter (page 4-21)	PDO CommPar	rw	O
1401 _{hex}	RECORD	2nd Receive PDO Parameter (page 4-21)	PDO CommPar	rw	O
1402 _{hex}	RECORD	3rd Receive PDO Parameter (page 4-21)	PDO CommPar	rw	O
...
141F _{hex}	RECORD	32nd Receive PDO Parameter (page 4-21)	PDO CommPar	rw	O
Receive PDO-Mapping Parameters					
1600 _{hex}	ARRAY	1st Receive PDO-Mapping (page 4-24)	PDO mapping	rw	O
1601 _{hex}	ARRAY	2nd Receive PDO-Mapping (page 4-24)	PDO mapping	rw	O
1602 _{hex}	ARRAY	3rd Receive PDO-Mapping (page 4-24)	PDO mapping	rw	O
...
161F _{hex}	ARRAY	32nd Receive PDO-Mapping (page 4-24)	PDO mapping	rw	O
Transmit PDO Communication Parameter					
1800 _{hex}	RECORD	1st Transmit PDO Parameter (page 4-27)	PDO CommPar	rw	O
1801 _{hex}	RECORD	2nd Transmit PDO Parameter (page 4-27)	PDO CommPar	rw	O

Table 16:
Object overview for the
communication
Profile CiA
DS-301

Index (hex)	Object	Name	Type	Access	M/O/C
1802 _{hex}	RECORD	3rd Transmit PDO Parameter (page 4-27)	PDO CommPar	rw	O
...
181F _{hex}	RECORD	32nd Transmit PDO Parameter (page 4-27)	PDO CommPar	rw	O
Transmit PDO-Mapping Parameter					
1A00 _{hex}	ARRAY	1st Transmit PDO-Mapping (page 4-30)	PDO mapping	rw	O
1A00 _{hex}	ARRAY	2nd Transmit PDO-Mapping (page 4-30)	PDO mapping	rw	O
1A02 _{hex}	ARRAY	3rd Transmit PDO-Mapping (page 4-30)	PDO mapping	rw	O
...
1A1F _{hex}	ARRAY	32nd Transmit PDO Mapping (page 4-30)	PDO mapping	rw	O
NMT Master Objects					
1F80 _{hex}	VAR	NMT Start-up (page 4-33)	Unsigned32	rw	O
1F81 _{hex}	ARRAY	Slave Assignment (page 4-34)	Unsigned32	rw	O
1F82 _{hex}	ARRAY	Request NMT (page 4-36)	Unsigned8	rw	O
1F83 _{hex}	ARRAY	Request Guarding (page 4-38)	Unsigned8	rw	O

4.1.1 Object 1000_{hex} – Device Type

Object 1000_{hex} contains the Type and Function for the station.

The value FFFF 0191_{hex} indicates that all Device Profiles are supported.

Table 17:
Object 1000_{hex}

Object description	
INDEX	1000 _{hex}
Name	Device Type
Object code	VAR
Data type	Unsigned32
Value range	
Access	ro
PDO mapping	No
Value range	Unsigned32
Default value, BLxx	FFFF 0191 _{hex}
Default value, BLxx	depends on the respective module

4.1.2 Object 1001_{hex} – Error Register

The object 1001_{hex} contains the Error register for the CANopen gateway. It thus contains, in one byte, the internal errors that occur.

Table 18:
Object 1001_{hex}

Object description	
INDEX	1001 _{hex}
Name	Error register
Object code	VAR
Data type	Unsigned8
Value range	
Access	ro
PDO mapping	Optional
Value range	Unsigned8
Default value, BLxx	00 _{hex}

Error register

Bit 0	Bit 1	Bit 2	Bit 3	Bit 4	Bit 5	Bit 6	Bit 7
Generic	Current	Voltage	0	Comm.	0	0	Manu.

Abbreviations:

Abbr.	Meaning	Valid for Modules
generic	General error	all modules
Current	Output short-circuit/ current error	DO, AI,TC
Voltage	voltage error	PF, DO, AI, AO
Comm.	communication error	all modules
Manu.	Manufacturer-specific error	all modules

4.1.3 Object 1005_{hex} – SYNC COB-ID

Object 1005_{hex} defines the COB-ID and thus the priority (→ „Identifier for the die standard objects“) of the synchronization object (SYNC). The BLxx-CANopen-gateway is not able to generate, but only to receive, SYNC messages.

Structure of the SYNC COB-ID entry (Unsigned32):

Bits	MSB			LSB	
	31	30	29	28 to 11	10 to 0
11-bit ID	x	0	0	00 0000 0000 0000 0000	11-bit Identifier
29-bit ID	x	0	1	29-bit Identifier	

Table 19:
Description of
the SYNC COB-
ID entry

Bit no.	Value	Description
31 (MSB)	X	fixed
30	0	Module does not generate a SYNC message
	1	Module generates a SYNC message
29	0	11-bit ID (CAN 2.0A) for BLxx
	1	29-bit ID (CAN 2.0B)
28 to 11	0	if bit 29 = 0
	X	if bit 29 = 1 bits 28 to 11 of the SYNC-COB-ID
10 to 0 (LSB)	X	bits 10 to 0 of the SYNC-COB-ID



Note

Bit 30 is static, i.e. cannot be changed.

Table 20:
Object 1005_{hex}

Object description	
INDEX	1005 _{hex}
Name	COB-ID
Object code	VAR
Data type	Unsigned32
Value range	
Access	rw
PDO mapping	No
Value range	Unsigned32
Default value, BLxx	0000 0080h

4.1.4 Object 1008_{hex} – Device Name

Object 1008_{hex} contains the manufacturer-specific device name

Table 21:
Object 1008_{hex}

Object description	
INDEX	1008 _{hex}
Name	manufacturer specific device name
Object code	VAR
Data type	Visible String
Value range	
Access	const.
PDO mapping	No
Value range, BLxx	–
Default value	depends on the gateway/ module

4.1.5 Object 1009_{hex} – Manufacturer Hardware Version

Object 1009_{hex} contains the designation for the Hardware Version.

Table 22:
Object 1009_{hex}

Object description	
INDEX	1009 _{hex}
Name	Hardware version
Object code	VAR
Data type	Visible String
Value range	
Access	const.
PDO mapping	No
Value range, BLxx	–
Default value, BLxx	depends on the gateway/ module

4.1.6 Object 100A_{hex} – Manufacturer Software Version

Object 100A_{hex} contains the device's software version.

Table 23:
Object 100A_{hex}

Object description	
INDEX	100A _{hex}
Name	Software version
Object code	VAR
Data type	Visible String
Value range	
Access	const.
PDO mapping	No
Value range, BLxx	–

4.1.7 Object 100C_{hex} – Guard Time

Object 100C_{hex} contains the Guard time in milliseconds. The product of "Lifetime factor" (Object 100D_{hex}) and Guard time is the "Lifetime" for the Node Guarding.

Table 24:
Object 100C_{hex}

Object description	
INDEX	100C _{hex}
Name	Guard Time
Object code	VAR
Data type	Unsigned16
Value range	
Access	rw
PDO mapping	No
Value range, BLxx	Unsigned16
Default value, BLxx	0

4.1.8 Object 100D_{hex} – Lifetime Factor

If the Lifetime factor is multiplied by the Guard time, the result is the Lifetime for Node Guarding.

Example:

Guard Time 100 ms

Lifetime Factor:.....3

With a Guard Time of 100 ms, the network nodes expect a guard telegram every 100 ms. The Lifetime factor enables a setting to be made in the BLxx-gateway for how often a Guard Frame from the Master can be missed before an error condition is recognized. In this example, the relevant time would be 300 ms. The evaluation would only become active after the message had been missing for 300 ms.

Table 25:
Object 100D_{hex}

Object description	
INDEX	100D _{hex}
Name	Lifetime Factor
Object code	VAR
Data type	Unsigned8
Value range	
Access	rw
PDO mapping	No
Value range, BLxx	Unsigned8
Default value, BLxx	0

4.1.9 Object 1010_{hex} – Store Parameters

The object 1010_{hex} can be used to save parameter changes in non-volatile memory. The command is executed by writing the data contents 6576 6173_{hex} ("save") to one of the Sub-indices.

Table 26:
Object 1010_{hex}

Object description	
INDEX	1010 _{hex}
Name	Store Parameters
Object code	3 _{hex}
Data type	Unsigned32
Value description	
Sub-index	00 _{hex}
Description	Largest Supported Index
Access	ro
PDO mapping	No
Default value, BLxx	3 _{hex}
Sub-index	01 _{hex}
Description	Save all Parameters
Access	rw
PDO mapping	No
Value range, BLxx	Unsigned32
Default value, BLxx	-
Sub-index	02 _{hex}
Description	Save Communication Parameters
Access	rw
PDO mapping	No
Value range, BLxx	Unsigned32
Default value, BLxx	-
Sub-index	03 _{hex}
Description	Save Application Parameters
Access	rw
PDO mapping	No
Value range, BLxx	Unsigned32
Default value, BLxx	-

4.1.10 Object 1011_{hex} – Restore Default Parameters

The object 1011_{hex} can be used to restore the default parameters. The command is executed by writing the data contents 6461 6F6C_{hex} ("load") to one of the Sub-indices.

Table 27:
Object 1011_{hex}

Object description	
INDEX	1011 _{hex}
Name	Restore Default Parameters
Object code	ARRAY
Data type	3 _{hex}
Value description	
Sub-index	00 _{hex}
Description	Largest Supported Index
Access	ro
PDO mapping	No
Sub-index	01 _{hex}
Description	Restore All Default Parameters
Access	rw
PDO mapping	No
Value range, BLxx	Unsigned32
Default value, BLxx	-

Table 27:
Object 1011_{hex}

Object description	
Value description	
Sub-index	02 _{hex}
Description	Restore Communication Parameters
Access	rw
PDO mapping	No
Value range, BLxx	Unsigned32
Default value, BLxx	-
Sub-index	03 _{hex}
Description	Restore Application Parameters
Access	rw
PDO mapping	No
Value range, BLxx	Unsigned32
Default value, BLxx	-

4.1.11 Object 1014_{hex} – Emcy COB-ID

Object 1014_{hex} contains the Identifier for the Emergency Messages

Bits	MSB				LSB
	31	30	29	28 to 11	10 to 0
11-bit ID	0/1	0	0	00 0000 0000 0000 0000	11-bit Identifier
29-bit ID	0/1	0	1	29-bit Identifier	

Table 28:
Description of
the Emcy COB-
ID entry

Bit no.	Value	Description
31 (MSB)	0	EMCY exists/ is valid
	1	EMCY does not exist/ is not valid
30	0	reserved (always 0)
29	0	11-bit ID (CAN 2.0A) ∅ for BLxx
	1	29-bit ID (CAN 2.0B)
28 to 11	0	if bit 29 = 0
	X	if bit 29 = 1 bits 28 to 11 of 29-bit-COB-ID

Table 28:
Description of
the Emcy COB-
ID entry

Bit no.	Value	Description
10 to 0 (LSB)	X	bits 10 to 0 of COB-ID



Note

Bit 30 is static, i.e. cannot be changed.

Table 29:
Object 1014_{hex}

Object description	
INDEX	1014 _{hex}
Name	Emcy COB-ID
Object code	VAR
Data type	Unsigned32
Value description	
Access	rw
PDO mapping	No
Value range, BLxx	Unsigned32
Default value, BLxx	0000 0080 _{hex} + Node-ID

4.1.12 Object 1016_{hex} – Consumer Heartbeat Time

The Heartbeat Protocol is used to monitor the operational capability of other CANopen bus nodes. The Heartbeat Protocol must be seen as an alternative to Node-/Life-Guarding, which, unlike Guarding, does not use Remote-Frames.

A device generates the Heartbeat with a specific cycle time (see object 1017_{hex} "Producer heartbeat time"). Another device receives the Heartbeat and monitors the cycle time. Another device receives the Heartbeat and monitors the cycle time.

Object 1016 defines the cycle time (interval) at which the Heartbeat is expected. This cycle time should be longer than the corresponding cycle time for the transmitter (see object 1017_{hex}). The monitoring of the Heartbeat starts when the first Heartbeat Frame is received. If the Consumer heartbeat time = 0, then the corresponding entry will not be used.

The time is set as a multiple of 1 ms.

Structure of the entry for Consumer heartbeat time (Unsigned32):

	MSB		LSB
Bits	31 to 24	23 to 16	15 to 0
Value	reserved (default: 00 _{hex})	Node-ID	Heartbeat Time
Data type	–	Unsigned8	Unsigned16

Table 30:
Object 1016_{hex}

Object description	
INDEX	1016 _{hex}
Name	Consumer Heartbeat Time
Object code	ARRAY
Data type	Unsigned32
Value description	
Sub-index	00 _{hex}
Description	Number of Entries
Category	Mandatory
Access	ro
PDO mapping	No
Value range, BLxx	1
Default value, BLxx	1
Sub-index	01 _{hex}
Description	Consumer Heartbeat Time
Category	Mandatory
Access	rw
PDO mapping	No
Value range, BLxx	Unsigned32
Default value, BLxx	0

4.1.13 Object 1017_{hex} – Producer Heartbeat Time

The object 1017_{hex} defines the cycle time for the Heartbeat.

If the cycle time = 0, then Heartbeat will not be used. The content of the object is interpreted as a multiple of 1 ms.

Table 31:
Object 1017_{hex}

Object description	
INDEX	1017 _{hex}
Name	Producer Heartbeat Time
Object code	VAR
Data type	Unsigned16
Value description	
Access	rw
PDO mapping	No
Value range, BLxx	Unsigned16
Default value, BLxx	0

4.1.14 Object 1018_{hex} – Identity Object

Object 1018_{hex} contains general information about the BLxx gateway.

The Vendor-ID (Sub-index_{hex}) is a unique ID which precisely identifies the manufacturer. The manufacturer-specific Product-Code (Sub-index 02_{hex}) identifies a specific device version. The manufacturer-specific Revision-Number (Sub-index 03_{hex}) consists of a major revision number and a minor revision number. The major revision number defines a special CANopen functionality. If the CANopen functionality is expanded, then the major revision number must be incremented. The minor revision number identifies various versions that have the same CANopen functionality.

	MSB	LSB
Bits	31 to 16	15 to 0
Value	Major Revision Number	Minor Revision Number

Table 32:
Object 1018_{hex}

Object description

INDEX	1018 _{hex}
Name	Device Specification
Object code	RECORD
Data type	Identity

Value description

Sub-index	00 _{hex}
Description	Number of Entries
Category	Mandatory
Access	ro
PDO mapping	No
Default value, BLxx	4

Value description

Sub-index	01 _{hex}
Description	Manufacturer-ID
Category	Mandatory
Access	ro
PDO mapping	No
Value range, BLxx	Unsigned32
Default value, BLxx	0000 009C _{hex}

Table 32:
 Object 1018_{hex}

Object description

Sub-index	02 _{hex}
Description	Product Code
Category	Option
Access	ro
PDO mapping	No
Value range, BLxx	Unsigned32
Sub-index	03 _{hex}
Description	Revision number
Category	Option
Access	ro
PDO mapping	No
Value range, BLxx	Unsigned32
Default value, BLxx	No
Sub-index	04 _{hex}
Description	Serial number
Category	Option
Access	ro
PDO mapping	No
Value range, BLxx	Unsigned32

4.1.15 Object 1020_{hex} – Verify Configuration

Object 1020_{hex} is used to check the station configuration after a device reset.

The BLxx-CANopen gateway supports the non-volatile storage of parameters. A network configuration tool or an CANopen Manager can use object 1020_{hex} to test the station configuration after a reset, and so check whether a reconfiguration is necessary. The configuration tool saves the time and date simultaneously in object 1020_{hex} and the corresponding DCF file. After a reset, the most recent configuration and the signature will be restored, either automatically on request. If the configuration values are altered by some other command, then the object will be set to 0.

The Configuration Manager compares the signature and the configuration with the values from the DCF file. If it discovers any deviations, a reconfiguration will be necessary.

Table 33:
Object 1020_{hex}

Object description	
INDEX	1020 _{hex}
Name	Verify Configuration
Object code	ARRAY
Data type	Unsigned16
Value description	
Sub-index	00 _{hex}
Description	Number of entries
Access	rw
PDO mapping	No
Default value, BLxx	02 _{hex}
Sub-index	01 _{hex}
Description	Configuration date
Access	rw
PDO mapping	No
Value range, BLxx	Unsigned32
Default value, BLxx	No
Sub-index	02 _{hex}
Description	Configuration time
Access	rw
PDO mapping	No
Value range, BLxx	Unsigned32
Default value, BLxx	No



Note

The configuration date contains the number of days since January 01 1984. The configuration time contains the number of milliseconds since midnight.

4.1.16 Object 1027_{hex} – Module List

Object 1027_{hex} describes all the actually installed modules in a station.

It is only valid for modular devices and thus not for BLCCO.

Table 34:
Object 1027_{hex}

Object description		
INDEX	1027 _{hex}	
Name	Module List	
Object code	ARRAY	
Data type	Unsigned16	
Access	ro	
Value description		
Sub-index	00 _{hex}	
Description	Number of connected modules	
Access	ro	
PDO mapping	No	
Value range, BLxx	00 _{hex} to 4A _{hex}	
Default value, BLxx	No	
Sub-index	01 _{hex}	
Description	Module 1	
...	...	
	BL20	BL67
Sub-index	4A _{hex}	20 _{hex}
Description	Module 74	Module 32

The sequential Sub-indices 01_{hex} to 4A_{hex} (BL20) or resp. 20_{hex} (BL67) describe the corresponding BLxx modules in the sequence in which they are installed in the station. Each entry contains a number that identifies the particular module. Each entry contains a number which identifies the respective module.



Note

There is one identifier for each type of BLxx module.

In the EDS-file, the individual extensions to object 1027_{hex} (e.g. M1SubExt1027) for all the optional BLxx module types are listed in the section [Supported Modules]. The default values (e.g. default value=8000_{hex}) correspond to the identifiers for the particular module types (e.g. [M1ModuleInfo] ProductName=Generic BLxx-BR/-PF).

4.2 Objects for the Transfer of Service Data

4.2.1 Objects 1200_{hex} to 1203_{hex} – Server SDO Default Parameters

Objects 1200_{hex} to 1203_{hex} define the priority for the transmission of SDO1 to SDO4.
The priority of the data is defined through the Identifier/ COB-ID

Table 35:
Object 1200_{hex}
to 1203_{hex}

Object description	
INDEX	1200 _{hex} to 1203 _{hex}
Name	Server SDO Parameters
Object code	RECORD
Number of Elements	3 _{hex}
Data type	SDO-parameters
Value description	
Sub-index	00 _{hex}
Description	Number of entries
Access	ro
PDO mapping	No
Default value, BLxx	02 _{hex}
Sub-index	01 _{hex}
Description	COB-ID Client Server (rx)
Access	Index 1200 _{hex} :ro Index 1201 _{hex} to 1203 _{hex} :rw
PDO mapping	No
Value range, BLxx	Unsigned32
Default value, BLxx	Index 1200 _{hex} : 0000 0600 _{hex} + Node-ID Index 1201 _{hex} to 1203 _{hex} :rwNo
Sub-index	02 _{hex}
Description	COB-ID Server Client (rx)
Access	Index 1200 _{hex} :ro Index 1201 _{hex} to 1203 _{hex} :rw
PDO mapping	No
Value range, BLxx	Unsigned32

Table 35:
Object 1200_{hex}
to 1203_{hex}

Object description

Default value, BLxx	Index 1200 _{hex} : 0000 0580 _{hex} + Node-ID Index 1201 _{hex} to 1203 _{hex} :rwNo
---------------------	---

4.3 Objects for the Transfer of Process Output Data

The objects 1400_{hex} to 141F_{hex} define, together with objects 1600_{hex} to 161F_{hex}, which output data have to be transferred via RPDO. In addition to that, the priority and the transmission type for the RPDO-transfer are defined.

Object 1400_{hex} defines the priority and the transmission type for the RPDO1. Object 1600_{hex} defines the object-index, the sub-index and the data length for the data which have to be transferred via RPDO1.

Objects 1401_{hex} and 1601_{hex} thus define the RPDO2, etc.

The priority of the data is defined through the Identifier/ COB-ID

The values are already entered by default for objects 1400_{hex} to 1403_{hex} and 1600_{hex} to 1603_{hex}.

A station with up to 64 digital outputs and 12 analog outputs therefore transfers the process output data automatically via RPDOs.

4.3.1 Object 1400_{hex} to 141F_{hex} – Receive PDO Comm. Default Parameters

Objects 1400_{hex} to 141F_{hex} define the priority for the transmission of RPDO11 to RPDO32.

The priority is defined via the identifier/COB-ID (see „Identifier for the Standard Objects“) in sub-index 01_{hex}.

With the highest bit of sub-index 01_{hex}, the further content can be defined as valid/invalid. The respective highest_{hex} adecimal number is then > 8.

The transmission type is defined with the sub-index 02_{hex}.

Which data content is to be transferred with the RPDO1 to RPDO32 is defined with the objects 1600_{hex} to 161F_{hex}.

Table 36:
Object 1400_{hex}
to 141F_{hex}

Object description

	BLxx	BLC
INDEX	1400 _{hex} to 141F _{hex}	1400 _{hex} to 1403 _{hex}

Name Receive PDO Parameters

Object code RECORD

Data type PDO CommPar

Value description

Sub-index 00_{hex}

Description Maximum Number of Entries

Access ro

Device (gateway) objects

Table 36:
Object 1400_{hex}
to 141F_{hex}

Object description	BLxx	BLC
PDO mapping		No
Value range, BLxx		2
Default value, BLxx		02 _{hex}
Sub-index		01 _{hex}
Description	COB-ID for the PDOs (see Table 37:)	
Access		rw
PDO mapping		No
Value range, BLxx		Unsigned32
Default value, BLxx	Index 1400 _{hex} : 0000 0200 _{hex} + Node-ID Index 1401 _{hex} : 0000 0300 _{hex} + Node-ID Index 1402 _{hex} : 0000 0400 _{hex} + Node-ID Index 1403 _{hex} : 0000 0500 _{hex} + Node-ID	
	Index 1404 _{hex} to 141F _{hex} : reserved	
Sub-index		02 _{hex}
Description	Transmission type (see Table 38:)	
Access		rw
PDO mapping		No
Value range, BLxx		Unsigned8
Default value, BLxx		FF _{hex}

Structure of the COB-ID entry

Bits	MSB				LSB
	31	30	29	28 to 11	10 to 0
11-bit ID	0/1	0/1	0	00 0000 0000 0000 0000	11-bit Identifier
29-bit ID	0/1	0/1	1	29-bit Identifier	

Table 37:
Description of
the COB-ID-
entry

Bit no.	Value	Meaning
31 (msb)	0	PDO exists / is valid
	1	PDO does not exist / is invalid
30	0	RTR is possible in this PDO
	1	RTR is not possible in this PDO
29	0	11-Bit-ID (CAN 2.0A) (standard application)
	1	29-bit ID (CAN 2.0B)
28 to 11	0	if bit 29=0 (Standard application)
	X	if bit 29 = 1 bits 28 to 11 of COB-ID
10 to 0 (lsb)	X	bits 10 to 0 of COB-ID

The Transmission type (Sub-index 02_{hex}) can have the following values:

Table 38:
Description of
the
Transmission
Type

Transmission Type	PDO transmission				
	cyclic	acyclic	synchr.	asynchr.	only with RTR
0		×	×		
1	×		×		
2 to 254	reserved				
255				×	

4.3.2 Object 1600_{hex} to 161F_{hex} – Receive PDO-Mapping Parameter

Objects 1600_{hex} to 161F_{hex} (BLCCO: 1600_{hex} to 1603_{hex}) define, which data have to be transferred with RPDO1 to RPDO32 (BLCCO: RPDO1 to RPDO 4).

The data content (here: process output data) is represented by product specific mappable objects.

→ [Mappable Objects \(page 2-22\)](#)

For example, the process output data for the digital channels are entered in objects 6200_{hex}, 6220_{hex} etc.

The description of these objects can be found in the following chapter.

Sub-indices 01_{hex} ff. of the objects 1600_{hex} to 161F_{hex} (BLCCO: 1600_{hex} to 1603_{hex}) contain the object number, the sub-index and the length of the data that have to be transferred via the respective RPDO.

An RPDO can transfer a maximum number of 8 bytes (64 bit).

The number of sub-indices depends on the data length. For larger projects, it has to be calculated and entered by user.

At a data length of 8 bit, 8 sub-indices are needed to represent a total number of 64 bit. At a data length of 1 bit, 64 sub-indices are needed to represent a total number of 64 bit.

Objects 1600_{hex} to 1603_{hex} (RPDO1 to RPDO4) references by default the values for the first 64 digital output channels and for the first 12 analog output channels, provided that the values are represented by the objects 6200_{hex} (digital values) and 6411_{hex} (analog values).

Table 39:
Object 1600_{hex}
to 161F_{hex}

Object description	BLxx	BLCCO
INDEX	1600 _{hex} to 161F _{hex}	1600 _{hex} to 1603 _{hex}
Name	Receive PDO-Mapping Parameters	
Object code	RECORD	
Data type	PDO mapping	
Value description		
Sub-index	00 _{hex}	
Description	NumberOfMappedApplication Objects	Receive PDO-Mapping Parameters
Access	rw	rw
PDO mapping	No	No
Value range, BLxx	0 to 64	-
Default value, BLxx	see Table 16:	-
Sub-index		01 _{hex}
Description	1st Mapping Object	
Access	rw	
PDO mapping	No	

Table 39:
Object 1600_{hex}
to 161F_{hex}

Object description	BLxx	BLCCO
Value range, BLxx		Unsigned32
Default value, BLxx		see Table 16:
...		...
Sub-index	40 _{hex}	03 _{hex}
Description	64th Mapping Object	4th Mapping Object
Access	rw	rw
PDO mapping	No	No
Value range, BLxx	Unsigned32	Unsigned32
Default value, BLxx	No	No

Default values for objects 1600_{hex} to 1603_{hex}:



Note

The number of mapping objects, which are automatically generated by the gateway during start-up, depends on the actual physical structure of the BLxx-station.

Table 40:
Default values
for objects
1600_{hex} to
1603_{hex}

Object	Product	Sub-index	Default value	Description	valid for
1600 _{hex}	BLxx	01 _{hex}	6200 0108 _{hex}	1st Mapping Object (digital output)	RPDO1
		
		08 _{hex}	6200 0808 _{hex}	8th Mapping Object (digital output)	
1601 _{hex}	BLCCO	01 _{hex}	6200 0108 _{hex}	1st Mapping Object (digital output)	RPDO1
		
		04 _{hex}	6411 0410 _{hex}	4th Mapping Object (analog output)	
1600 _{hex}	BLxx	01 _{hex}	6411 0110 _{hex}	1st Mapping Object (analog output)	RPDO2
		
		04 _{hex}	6411 0410 _{hex}	4th Mapping Object (analog output)	
1601 _{hex}	BLCCO	01 _{hex}	6411 0110 _{hex}	1st Mapping Object (analog output)	RPDO2
		
		04 _{hex}	6411 0410 _{hex}	4th Mapping Object (analog output)	

Device (gateway) objects

Table 40:
Default values
for objects
1600_{hex} to
1603_{hex}

Object	Product	Sub-index	Default value	Description	valid for
1602 _{hex}	BLxx	01 _{hex}	6411 0510 _{hex}	1st Mapping Object (analog output)	RPDO3
		
		04 _{hex}	6411 0810 _{hex}	4th Mapping Object (analog output)	
BLCCO					
1603 _{hex}	BLxx	01 _{hex}	6411 0910 _{hex}	1st Mapping Object (analog output)	RPDO4
		
		04 _{hex}	6411 0C10 _{hex}	4th Mapping Object (analog output)	
BLCCO					
		01 _{hex}	6411 0510 _{hex}	1st Mapping Object (analog output)	RPDO4

The following structure applies to the parameters for sub-indices:

Structure of the PDO Mapping entries:

MSB		LSB
Index (16 bit)	Sub-Index (8 bit)	Object length (8 bit)



Note

To change the number of mapping entries, follow the instructions in section .
[Procedure for Altering PDO-Mappings \(page 2-23\).](#)

4.4 Objects for the Transfer of Process Input Data

Objects 1800_{hex} to 181F_{hex} (BLCCO: 1800_{hex} to 1803_{hex}) define, together with objects 1A00_{hex} to 1A1F_{hex} (BLCCO: 1A00_{hex} to 1A03_{hex}), which input data are transferred. Additionally they define the priority and the mode for the data transfer via TPDO.

Object 1800_{hex} defines the priority, the minimum inhibit time, the event timer and the transmission type for TPDO1. Object 1A00_{hex} defines the object-index, the sub-index and the data length for the data which have to be transferred via TPDO1.

Objects 1801_{hex} and 1A01_{hex} thus define the TPDO2, etc.

The priority of the data is defined through the Identifier/ COB-ID

The values are already entered by default for objects 1800_{hex} to 1803_{hex} and 1A00_{hex} to 1A03_{hex}.

A station with up to 64 digital outputs and 12 analog outputs therefore transfers the process input data automatically via TPDOs.

4.4.1 Object 1800_{hex} to 181F_{hex} – Transmit PDO-Parameters

Objects 1800_{hex} to 181F_{hex} (BLCCO: 1800_{hex} to 1803_{hex}) define the priority, the transmission type, the inhibit time and the event timer for TPDO1 to TPDO32.

The priority is defined via the identifier/COB-ID (see „Identifier for the Standard Objects“) in sub-index 01_{hex}.

With the highest bit of sub-index 01_{hex}, the further content can be defined as valid/invalid. The respective highest_{hex} adecimal number is then > 8.

The transmission type is defined with the sub-index 02_{hex}.

The inhibit time is defined in sub-index 03_{hex}.

The maximum time between 2 transmissions, the event timer, is defined in sub-index 05_{hex}.

Which data content is to be transferred with the RPDO1 to RPDO32 is defined with the objects 1A00_{hex} to 1A1F_{hex}. (BLCCO: 1A00_{hex} to 1A03_{hex}).

Table 41:
Object 1800_{hex}
to 181F_{hex}

Object description	BLxx	BLCCO
INDEX	1800 _{hex} to 181F _{hex}	1800 _{hex} to 1803 _{hex}
Name	Transmit PDO-parameters	
Object code	RECORD	

Table 41:
Object 1800_{hex}
to 181F_{hex}

Object description	BLxx	BLCCO
Data type		PDO CommPar
Value description		
Sub-index		00 _{hex}
Description		Highest Sub-Index Used
Access		ro
PDO mapping		No
Value range		5
Default value		No
<hr/>		
Sub-index		01 _{hex}
Description		COB-ID of the PDO
Access		rw
PDO mapping		No
Value range, BLxx		Unsigned32
Default value, BLxx		Index 1800 _{hex} : 0000 0180 _{hex} + Node-ID Index 1801 _{hex} : 0000 0280 _{hex} + Node-ID Index 1802 _{hex} : 0000 0380 _{hex} + Node-ID Index 1803 _{hex} : 0000 0480 _{hex} + Node-ID
	Index 1804 _{hex} to 181F _{hex} :	-
Value description		
Sub-index		02 _{hex}
Description		Transmission Type
Access		rw
PDO mapping		No
Value range, BLxx		Unsigned8
Default value, BLxx		FFh
<hr/>		
Sub-index		03 _{hex}
Description		Inhibit Time
Access		rw
PDO mapping		No
Value range, BLxx		Unsigned16

Table 41:
Object 1800_{hex}
to 181F_{hex}

Object description	BLxx	BLCCO
Default value, BLxx		0
Sub-index		04 _{hex}
Description		reserved
Sub-index		05 _{hex}
Description		Event Timer
Access		rw
PDO mapping		No
Value range, BLxx		Unsigned16 (0 is not used)
Default value, BLxx		0

The COB-ID (sub-Index 01_{hex}) shows the following structure:

	MSB	LSB			
Bits	31	30	29	28 to 11	10 to 0
11-bit ID	0/1	0/1	0	00 0000 0000 0000 0000	11-bit Identifier
29-bit ID	0/1	0/1	1	29-bit Identifier	

Table 42:
Description of
the COB-ID
entry (sub-index
01_{hex})

Bit no.	Value	Description
31 (MSB)	0	PDO exists / is valid
	1	PDO does not exist / is invalid
30	0	RTR is possible in this PDO
	1	RTR is not possible in this PDO
29	0	11-Bit-ID (CAN 2.0A) (standard application)
	1	29-bit ID (CAN 2.0B)
28 to 11	0	if bit 29=0 (Standard application)
	X	if bit 29 = 1 bits 28 to 11 of COB-ID
10 to 0 (LSB)	X	bits 10 to 0 of COB-ID

The Transmission type (Sub-index 02_{hex}) can have the following values:

Table 43:
Transmission
Type

Transmission Type	PDO transmission				
	cyclic	acyclic	synchr.	asynchr.	only with RTR
0		×	×		
1	×		×		
2 to 252	reserved				
253				×	×
254	reserved				
255				×	

Inhibit time

In order to avoid a permanent occupation of the field bus by high-prior messages, the Inhibit Time is defined.

With sub-Index 03_{hex}, the Inhibit time is defined as a multiple of 100 μs. However, since the time resolution of the system clock in the BLxx-CANopen gateway is 1 ms, Inhibit time values below 10 x 100 μs are pointless.

Event Timer

Sub-index 03_{hex} defines the maximum interval after which a TPDO will be transmitted, even though no event has occurred. The expiry of the interval set for the Event timer is detected as an event.

If any other event occurs, the Event timer is reset and restarted.

The value of the object is interpreted as a multiple of 1 ms.

4.4.2 Objects 1A00_{hex} to 1A1F_{hex} - Transmit PDO Mapping Parameter

Die Objects 1A00_{hex} to 1A1F_{hex} (BLCCO: 1A00_{hex} to 1A03_{hex}) define, which data have to be transferred with TPDO1 to TPDO32.

The data content (here: process input data) is represented by product specific mappable objects.

see [Mappable Objects \(page 2-22\)](#)

For example, the process input data for the digital channels are entered in objects 6000_{hex}, 6020_{hex} etc.

The description of these objects can be found in the following chapter.

Sub-indices 01_{hex} ff. of the objects 1A00_{hex} to 1A1F_{hex} (BLCCO: 1A00_{hex} to 1A03_{hex}) contain the object number, the sub-index and the length of the data that have to be transferred via the respective TPDO.

A TPDO can transfer a maximum number of 8 bytes (64 bit).

The number of sub-indices depends on the data length. For larger projects, it has to be calculated and entered by user.

At a data length of 8 bit, 8 sub-indices are needed to represent a total number of 64 bit. At a data length of 1 bit, 64 sub-indices are needed to represent a total number of 64 bit.

Objects 1600_{hex} to 1603_{hex} (RPDO1 to RPDO4) references by default the values for the first 64 digital output channels and for the first 12 analog output channels, provided that the values are represented by the objects 6000_{hex} (digital values) and 6401_{hex} (analog values).

Table 44:
Object 1A00_{hex}
to 1A1F_{hex}

Object description	BLxx	BLCCO
INDEX	1A00 _{hex} to 1A1Fh	1A00 _{hex} to 1A03h
Name	Transmit PDO-Mapping Parameters	
Object code	RECORD	
Data type	PDO mapping	
Value description		
Sub-index	00 _{hex}	
Description	Number of Mapped Application Objects in the PDO	Transmit PDO-Mapping Parameters
Access	rw	
PDO mapping	No	
Value range, BLxx	0 deactivated 1 to 64: activated	
Default value, BLxx	see Table 38 :	
...		
Sub-index	01 _{hex}	
Description	1st Mapping Object	
Access	rw	
PDO mapping	No	
Value range, BLxx	Unsigned32	
Default value, BLxx	see page 4-32	
...		
Sub-index	40 _{hex}	
Description	64th Mapping Object	
Access	rw	
PDO mapping	No	
Value range, BLxx	Unsigned32	
Default value, BLxx	No	

Default values for objects 1A00_{hex} to 1A03_{hex} :



Note

The number of mapping objects, which are automatically generated by the gateway during start-up, depends on the actual physical structure of the BLxx-station.

Table 45:
Default values
for objects
1A00_{hex} to
1A03_{hex}

Object	Product	Sub-Index	Default value	Description	valid for
1A00 _{hex}	BLxx	01 _{hex}	6000 0108 _{hex}	1st Mapping Object (digital input)	TPDO1
		
	BLCCO	08 _{hex}	6000 0808 _{hex}	8th Mapping Object (digital input)	
		01 _{hex}	6000 0108 _{hex}	1st Mapping Object (digital input)	TPDO1
1A00 _{hex}	BLxx	01 _{hex}	6401 0110 _{hex}	1st Mapping Object (analog input)	TPDO2
		
	BLCCO	04 _{hex}	6401 0410 _{hex}	4th Mapping Object (analog input)	
		01 _{hex}	6401 0110 _{hex}	1st Mapping Object (analog input)	
1A02 _{hex}	BLxx	01 _{hex}	6401 0510 _{hex}	1st Mapping Object (analog input)	TPDO3
		
	BLCCO	04 _{hex}	6401 0810 _{hex}	4th Mapping Object (analog input)	
		01 _{hex}	6401 0510 _{hex}	1st Mapping Object (analog input)	TPDO3
1A03 _{hex}	BLxx	01 _{hex}	6401 0910 _{hex}	1st Mapping Object (analog input)	TPDO4
		
	BLCCO	04 _{hex}	6401 0C10 _{hex}	4th Mapping Object (analog input)	
		01 _{hex}	6401 0910 _{hex}	1st Mapping Object (analog input)	TPDO4

The following structure applies to the parameters for sub-indices 01_{hex} ff.:

MSB		LSB
Index (16 bit)	Sub-Index (8 bit)	Object length (8 bit)



Note

To change the number of mapping entries, follow the instructions in section [Procedure for Altering PDO-Mappings \(page 2-23\)](#).

4.5 Objects for network management (not valid for BLCCO)

Objects 1F80_{hex} to 1F83_{hex} are only relevant if the BLxx-station is to work as a Network Management Master. The activation is done via bit 0 from object 1F80_{hex}.

4.5.1 Object 1F80_{hex} – NMT Start-up

Object 1F80_{hex} describes the start-up behavior of BLxx in NMT (Network-Management).

Table 46:
Object 1F80_{hex}
to 1A1F_{hex}

Object description

INDEX	1F80 _{hex}
Name	NMT Start-up
Object code	VAR
Data type	Unsigned32
Access	rw

Table 47:
Structure of the
NMT-Start-up

Bit	Value	Meaning
0	0	BLxx station is not the NMT-Master All further bits will be ignored. The objects in the network list will be ignored.
	1	BLxx is the NMT-Master
1	0	Only the explicitly selected slaves will be started.
	1	After boot-up, the service "NMT Start Remote Node All Nodes" will be performed.
2	0	BLxx moves automatically to the "Operational" state.
	1	BLxx does not automatically move to the "Operational" state. The status change is defined through the respective application.
3	0	Starting of the slave is permitted.
	1	Starting of the slave is not permitted.

Table 47:
Structure of the
NMT-Start-up

Bit	Value	Meaning
4	0	An error event in an obligatory slave deals with the slave individually.
	1	An error event in an obligatory slave triggers an NMT Reset All Nodes (see object 1F81 _{hex} , bit 3).
5 to 31		Reserved; set to 0

4.5.2 Object 1F81_{hex} – Slave Assignment

Object 1F82_{hex} describes, as per CiA DSP-302, all the slaves that can be connected to Network Management (NMT). It contains information on error control and on actions which will be engaged through error events. All other parameters for a slave are only valid if this slave is described in object 1F81_{hex}.



Note

Object 1F81_{hex} is only valid if BLxx is defined as NMT Master (see „Object 1F80_{hex}“, Bit 0).

Table 48:
Object 1F81_{hex}

Object description	
INDEX	1F81 _{hex}
Name	Slave Assignment
Object code	ARRAY
Data type	Unsigned32
Access	rw
Value description	
Sub-index	00 _{hex}
Description	Maximum Number of Entries
Access	rw
PDO mapping	No
Value range	1 to 127
Default value	127
Sub-index	01 _{hex}
Description	Slave with Node-ID 1
Access	rw
PDO mapping	No
Value range, BLxx	Unsigned32
...	

Table 48:
Object 1F81_{hex}

Object description

Sub-index	3Fh
Description	Slave with Node-ID 63
Access	rw
PDO mapping	No
Value range, BLxx	Unsigned32
Default value, BLxx	No



Note

Each sub-index corresponds to the slave with the respective Node-ID. The sub-index with the Node-ID of the NMT-Master will be ignored.

Table 49:
Structure of the
object 1F81_{hex}
Slave
Assignment

Byte	Bit	Value	Meaning
0	0	0	The node with this ID is not a slave.
		1	The node with this ID is not a slave. After configuration, the node will be put into the "Operational" state.
1	0	0	An error event or other event detection by a slave during boot-up leads to information from the application.
		1	An error event or other event detection by a slave during boot-up leads to information from the application and to automatic start of Error Control Services.
2	0	0	An error event or other event detection by a slave during boot-up does not lead to information from the application or automatic start of Error Control Services.
		1	An error event or other event detection by a slave during boot-up leads to the start of "Start Boot Slaves".
3	0	0	Optional slave: the network can also be started if this node is not connected.
		1	Mandatory slave: the network will not be started if this node is not connected during the slave boot-up.
4	0	0	The slave can be reset by the "NMT Reset Communication" command, depending on its state.
		1	The NMT-Master does not have to send an "NMT Reset Communication" command for this slave, if the slave is in the "Operational" state.

Table 49:
Structure of the
object 1F81_{hex}
Slave
Assignment

Byte	Bit	Value	Meaning
0	5	0	Verification of the application software version is not required for this node.
		1	Verification of the application software version is required for this node.
	6	0	Automatic update of the application software (download) is not permitted.
		1	Automatic update of the application software (download) is permitted.
	7	Reserved; set to 0	
1			8 bit value for the Retry Factor
2 to 3	0		16 bit value for the Guard time

4.5.3 Object 1F82_{hex} – Request NMT

Object 1F82_{hex} describes, as per CiA DSP-302, all the slaves that can present queries to the Network Management (NMT).

Table 50:
Object 1F82_{hex}

Object description	
INDEX	1F82 _{hex}
Name	Query NMT
Object code	ARRAY
Data type	Unsigned8
Access	ro/rw
Value description	
Sub-index	00 _{hex}
Description	Supported Number of Slaves
Access	ro
PDO mapping	No
Value	128
Sub-index	01 _{hex}
Description	Request NMT-Service for slave with Node-ID 1
Access	rw

Table 50:
Object 1F82_{hex}

Object description

PDO mapping	No
Value range, BLxx	Unsigned8
Default value, BLxx	No
Sub-index	3Fh
Description	Request NMT-Service for slave with Node-ID 63
Access	rw
PDO mapping	No
Value range, BLxx	Unsigned8
Default value, BLxx	No
Sub-index	80 _{hex}
Description	Request NMT-Service for all slaves
Access	wo
PDO mapping	No
Value range, BLxx	Unsigned8
Default value, BLxx	No

For a write access to this object, the value corresponds to the state for the node to which the query is directed. For read access, the object contains the present state of the node.

Table 51:
Value range

Status	Value for Write access	Value for Read access
Stopped	4	4
Operational	5	5
Reset Node	6	–
Reset Communication	7	–
Pre-Operational	127	127
unknown	–	0
Node missing	–	1

4.5.4 Object 1F83_{hex} – Request Guarding

Object 1F83_{hex} describes, as per CiA DSP-302, all the slaves that can be monitored through the Network Management (NMT).

Table 52:
Object 1F83_{hex}

Object description	
INDEX	1F83 _{hex}
Name	Request Guarding
Object code	ARRAY
Data type	Unsigned8
Access	ro/rw
Value description	
Sub-index	00 _{hex}
Description	Supported Number of Slaves
Access	ro
PDO mapping	No
Value	128
Sub-index	01 _{hex}
Description	Request NMT-Service for slave with Node-ID 1
Access	rw
PDO mapping	No
Value range, BLxx	Unsigned8
Value	0 = Slave being monitored at present 1 = Slave not being monitored at present
...	
Sub-index	7Fh
Description	Request Guarding for Slave with Node-ID 63
Access	rw
PDO mapping	No
Value range	Unsigned8
Value	0 = Slave being monitored at present 1 = Slave not being monitored at present

Table 52:
Object 1F83_{hex}

Object description

Sub-index	80 _{hex}
Description	Request Start/Stop Guarding for all slaves
Access	wo
PDO mapping	No
Value range, BLxx	Unsigned8
Default value, BLxx	No

4.6 Overview about the objects of the Device Profile (acc. to CiA DS-401 and 406)

4.6.1 Object 67FF_{hex} – Device Type

The object 67FF_{hex} specifies the type of the first device profile supported.

The object contains the value 000x0191_{hex}.

Das Low-Word (0191_{hex}) specifies the device profile (acc. to CiA DS-401: I/O modules).

the high word (000x_{hex}) the I/O-types, see CiA DS-401.

Table 53:
Object 67FF_{hex}

Feature Description/ Value

Name	Device Type
Object code	VAR
Data type	Unsigned32
Access	ro
Default value	No
PDO mapping	No

4.6.2 Object 6FFF_{hex} – Device Type

Object 6FFF_{hex} (corresponds to object 67FF_{hex} in accordance with CiA DS-406) specifies the type of the second device profile supported.

The object contains the value 000A0191_{hex}.

The low word (0196_{hex} = 406dez) specifies the device profile.

The high word (000A_{hex}) describes the encoder type in accordance with CiA DS-406 (10dec = Multi Sensor Encoder Interface).

Table 54:
Object 6FFF_{hex}

Feature	Description
Name	Device Type
Object code	VAR
PDO Mapping	No
Data type	Unsigned32
Access	ro

4.7 Manufacturer specific device objects

4.7.1 Object 2000_{hex} – Serial Number

Object 2000_{hex} corresponds to sub-index 04_{hex} of object 1018_{hex} and contains the ident-number of the used BLxx-gateway.



Note

We recommend using object 1018_{hex}, sub-index 04_{hex} for the serial number.

4.7.2 Object 2010_{hex} – Node ResetModifiers

Object 2010_{hex} is used for a temporary (volatile) modification to the module behavior.

Table 55:
Object 2010_{hex}

Object description	
INDEX	2010 _{hex}
Name	Node ResetModifiers
Object code	ARRAY
Data type	Unsigned32
Value description	
Sub-index	00 _{hex}
Description	Number of Entries
Access	ro
PDO mapping	No
Value range, BLxx	Unsigned8
Default value, BLxx	No
Sub-index	01 _{hex}
Description	Hard Reset Node Identifier
Access	rw
PDO mapping	No
Value range, BLxx	Unsigned32
Default value, BLxx	No
Sub-index	02 _{hex}
Description	Save Reference Reset Modifier
Access	rw
PDO mapping	No
Value range, BLxx	Unsigned32
Default value, BLxx	No

Table 55:
Object 2010_{hex}

Object description	
Sub-index	03 _{hex}
Description	Save Current Reset Modifier
Access	rw
PDO mapping	No
Value range, BLxx	Unsigned32
Default value, BLxx	No

The Hard-Reset-Modifier determines whether, in the event of a Reset Node command, a normal fast reset should be performed, or a hard processor reset, which can take several seconds to be carried out.

For writing, the value that is transferred in Unsigned 32 format will be interpreted as a string:

Table 56:
Hard Reset
(processor reset)
selection

MSB		LSB	
t	s	r	h
74 _{hex}	73 _{hex}	72 _{hex}	68 _{hex}

Table 57:
Normal Reset
selection

MSB		LSB	
t	s	r	s
74 _{hex}	73 _{hex}	72 _{hex}	73 _{hex}

After the next Reset-Node or the next "Reset Communication" command, the operating mode will in all cases be reset to "normal Reset Node".

2010_{hex} at BLxx

The Index "Save reference module list" determines that, in the event of a Reset Node command, the BLxx reference module list (Objects 3080_{hex} and 3081_{hex}) will be saved in non-volatile memory, and then followed by a hard processor reset. This hardware reset is necessary, because changes to the BLxx0 reference module list cannot be dynamically accepted in the CANopen I/O mirror. If the module list is altered, all the CANopen parameters will be reset to the default values.

For writing, the value that is transferred in Unsigned 32 format will be interpreted as a string:

Table 58:
Selection: "Save
and Hardware-
Reset"

MSB		LSB	
v	a	s	r
76 _{hex}	61 _{hex}	73 _{hex}	72 _{hex}

<i>Table 59: Normal Reset selection</i>	MSB			LSB
	t	s	r	s
	74 _{hex}	73 _{hex}	72 _{hex}	73 _{hex}

After the next Reset-Node or the next "Reset Communication" command, the operating mode will in all cases be reset to "normal Reset Node".

The Index "Save Current Reset Modifier" determines that, in the event of a Reset Node command, the actual BLx module list (Objects 3090_{hex} and 3091_{hex}) will be saved in non-volatile memory, and then followed by a hard processor reset. This hardware reset is necessary, because changes to the reference module list cannot be dynamically accepted in the CANopen I/O mirror. If the module list is altered, all the CANopen parameters will be reset to the default values.

For writing, the value that is transferred in Unsigned 32 format will be interpreted as a string:

<i>Table 60: Save and Hard- ware-Reset selection</i>	MSB			LSB
	v	a	s	c
	76 _{hex}	61 _{hex}	73 _{hex}	63 _{hex}

<i>Table 61: Normal Reset selection</i>	MSB			LSB
	t	s	r	s
	74 _{hex}	73 _{hex}	72 _{hex}	73 _{hex}

After the next Reset-Node or the next "Reset Communication" command, the operating mode will in all cases be reset to "normal Reset Node".

4.7.3 Object 2400_{hex} - System Voltages (only BL67)

This object enables the reading of up to 4 system voltages.

At the moment, the BL67-GW-CO supports the reading of U_{sys} from sub-index 1. The sub-indices 2..4 give out 0.

Table 62:
Object 2400_{hex}

Object description	
INDEX	2400 _{hex}
Name	System Voltages
Object code	ARRAY
Data type	Unsigned16
Access	ro
PDO mapping	No
Default value	No

4.7.4 Object 2401_{hex} - System Currents (only BL67)

This object enables the reading of up to 4 system currents.

Table 63:
Object 2401_{hex}

Object description	
INDEX	2401 _{hex}
Name	System Currents
Object code	ARRAY
Data type	Unsigned16
Access	ro
PDO mapping	No
Default value	No

5 Objects for digital input modules

5.1	Digital input modules BLxx	2
5.2	General object overview for digital input modules	2
5.2.1	Object 6000 _{hex} – Read Input 8 Bit	4
5.2.2	Object 6020 _{hex} – Read Input Bit (1 to 128), Object 6021 _{hex} – Read Input Bit (129 to 256), Object 6022 _{hex} – Read Input Bit (257 to 288)	5
5.2.3	Object 6100 _{hex} – Read Input 16 Bit	6
5.2.4	Object 6120 _{hex} – Read Input 32 Bit	6

5.1 Digital input modules BLxx

The objects are used in the following modules:

*Table 64:
BLxx - digital
input modules*

Product family	Module
BL20	BL20-xDI-24VDC-P
	BL20-xDI-24VDC-N
	BL20-2DI-120/230VAC
	BL20-4DI-NAMUR
	BL20-E-xDI-24VDC-P
BL67	BL67-xDI-P
	BL67-xDI-N
	BL67-xDI-PD
BLC	miscellaneous

5.2 General object overview for digital input modules

*Table 65:
General object
overview for
digital input
modules*

Object	Name	Page
3064 _{hex}	XBIParam Dword	page 14-10
6000 _{hex}	Read Input 8 Bit	page 5-4
6020 _{hex}	Read Input Bit 1 to 128	page 5-5
6021 _{hex}	Read Input Bit 129 to 256	page 5-5
6022 _{hex}	Read Input Bit 257 to 288	page 5-5
6100 _{hex}	Read Input 16 Bit	page 5-6
6120 _{hex}	Read Input 32 Bit	page 5-6

The following figure shows the relationship between the digital input objects for an 8-bit access:

Figure 5:
Relationship
between the
digital
digital input
modules
(according to CiA
Standard DS401)

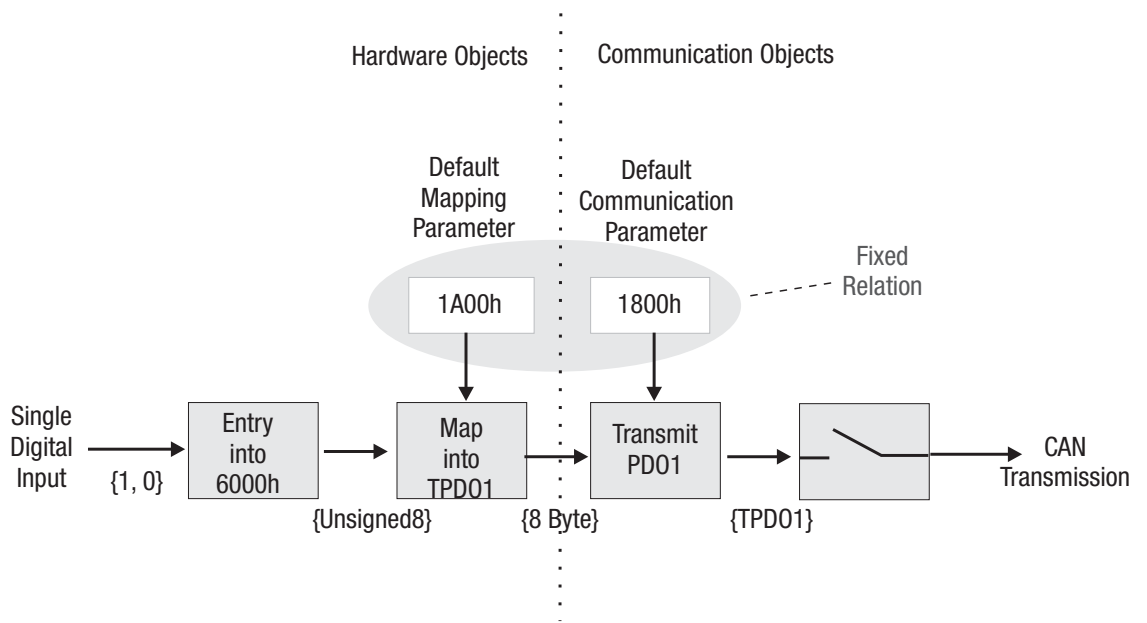

5.2.1 Object 6000_{hex} – Read Input 8 Bit

The object presents the values for the digital input modules in 8-bit groups.

A total of 36 groups (each 8 bit) can be displayed (288 digital input channels).

PDO mapping of this object is always executed by default and automatically for the first 8 sub-indexes. This corresponds to 64 input channels.

If more than 64 input channels are present, then the PDO-mapping must be carried out by the user.

Table 66:
Object 6000_{hex}

Feature	Description/ Value
Name	Read Input 8 Bit
Object code	ARRAY
PDO mapping	Yes
Sub-index	00 _{hex}
Data type	Unsigned8
Access	ro
Default value, BLxx	No
Sub-index	01 _{hex} to 24 _{hex}
Data type	Unsigned8
Access	ro
Default value, BLxx	No

5.2.2 Object 6020_{hex} – Read Input Bit (1 to 128), Object 6021_{hex} – Read Input Bit (129 to 256), Object 6022_{hex} – Read Input Bit (257 to 288)

The objects defined the values bit-wise. Each sub-index for these objects is a Boolean value.

A total of 128 bits can be represented (128 digital input channels).

If more than 128 input channels are present, then object 6021_{hex} is used.

If more than 256 input channels are present, then object 6022_{hex} is used.

Since the number of digital input channels in a station is limited to 288, it is not possible to make use of the complete range of the array in object 6022_{hex}.

Table 67:
Objects 6020_{hex},
6021_{hex} and
6022_{hex}

Feature	Description/ Value
Name	Read Input Bit
Object code	ARRAY
PDO mapping	Yes
Sub-index	00 _{hex}
Data type	Unsigned8
Access	ro
Default value, BLxx	No
Sub-index	01 _{hex} to 80 _{hex}
Data type	Boolean
Access	ro
Default value, BLxx	No

5.2.3 Object 6100_{hex} – Read Input 16 Bit

The object presents the values for the digital input modules in 16-bit groups.
A total of 18 groups (each 16 bit) can be displayed (288 digital input channels).

Table 68:
Object 6100_{hex}

Feature	Description/ Value
Name	Read Input 16 Bit
Object code	ARRAY
PDO mapping	Yes
Sub-index	00 _{hex}
Data type	Unsigned8
Access	ro
Sub-index	01 _{hex} to 12 _{hex}
Data type	Unsigned16
Access	ro

5.2.4 Object 6120_{hex} – Read Input 32 Bit

The object presents the values for the digital input modules in 32-bit groups.
A total of 9 groups (each 32 bit) can be displayed (288 digital input channels).

Table 69:
Object 6120_{hex}

Feature	Description/ Value
Name	Read Input 32 Bit
Object code	ARRAY
PDO mapping	Yes
Sub-index	00 _{hex}
Data type	Unsigned8
Access	ro
Sub-index	01 _{hex} to 09 _{hex}
Data type	Unsigned32
Access	ro

6 Objects for digital output modules

6.1	Digital output modules BLxx	2
6.2	General object overview for digital output modules	3
6.2.1	Object 6200 _{hex} – Write Output 8 Bit	4
6.2.2	Object 6206 _{hex} – Error Mode Output 8 Bit	5
6.2.3	Object 6207 _{hex} – Error State Output 8 Bit	6
6.2.4	Object 6220 _{hex} – Write Output Bit (1 to 128), Object 6221 _{hex} – Write Output Bit (129 to 256), Object 6222 _{hex} – Write Output Bit (257 to 288)	7
6.2.5	Object 6250 _{hex} – Error Mode Output Bit (1 to 128), Object 6251 _{hex} – Error Mode Output Bit (129 to 256), Object 6252 _{hex} – Error Mode Output Bit (257 to 288)	8
6.2.6	Object 6260 _{hex} – Error State Output Bit (1 to 128), Object 6261 _{hex} – Error State Output Bit (129 to 256), Object 6262 _{hex} – Error State Output Bit (257 to 288)	9
6.2.7	Object 6300 _{hex} – Write Output 16 Bit	10
6.2.8	Object 6306 _{hex} – Error Mode Output 16 Bit	10
6.2.9	Object 6307 _{hex} – Error State Output 16 Bit	11
6.2.10	Object 6320 _{hex} – Write Output 32 Bit	12
6.2.11	Object 6326 _{hex} – Error Mode Output 32 Bit	13
6.2.12	Object 6327 _{hex} – Error State Output 32 Bit	14

6.1 Digital output modules BLxx

The objects are used in the following modules:

<i>Table 70: BLxx - digital output modules</i>	Product family	Module
	BL20	BL20-xDO-24VDC-0.5A-P BL20-xDO-24VDC-0.5A-N BL20-2DO-24VDC-2A-P BL20-xDO-24VDC-0.5A-P BL20-2DO-120/230VAC-0.5A BL20-2DO-R-NC BL20-2DO-R-NO BL20-2DO-R-CO
	BL67	BL67-xDO-0.5A-P BL67-4DO-2A-P BL67-4DO-4A-P BL67-16DO-0.1A-P BL67-4DO-2A-N BL67-8DO-0.5A-N BL67-8DO-R-NO BL67-4DI4DO-PD BL67-8XSG-PD
	BLC	miscellaneous

6.2 General object overview for digital output modules

<i>Table 71: General object overview for digital output modules</i>	Object	Name	page
	6200 _{hex}	Write Output 8 Bit	page 6-4
	6206 _{hex}	Error Mode Output 8 Bit	page 6-5
	6207 _{hex}	Error State Output 8 Bit	page 6-6
	6220 _{hex}	Write Output 8 Bit (1 to 128)	page 6-7
	6221 _{hex}	Write Output 8 Bit (129 to 256)	page 6-7
	6222 _{hex}	Write Output 8 Bit (257 to 288)	page 6-7
	6250 _{hex}	Error Mode Output Bit (1 to 128)	page 6-8
	6251 _{hex}	Error Mode Output Bit (129 to 256)	page 6-8
	6252 _{hex}	Error Mode Output Bit (257 to 288)	page 6-8
	6260 _{hex}	Error State Output Bit (1 to 128)	page 6-9
	6261 _{hex}	Error State Output Bit (129 to 256)	page 6-9
	6300 _{hex}	Write Output 16 Bit	page 6-10
	6306 _{hex}	Error Mode Output 16 Bit	page 6-10
	6307 _{hex}	Error State Output 16 Bit	page 6-11
	6320 _{hex}	Write Output 32 Bit	page 6-12
	6326 _{hex}	Error Mode Output 32 Bit	page 6-13
	6327 _{hex}	Error State Output 32 Bit	page 6-14

The following figure shows the relationship between the digital output objects for an 8-bit access:

Figure6:
Relationship
between the
digital output
objects
(according to CiA
Draft Standard
DS401)

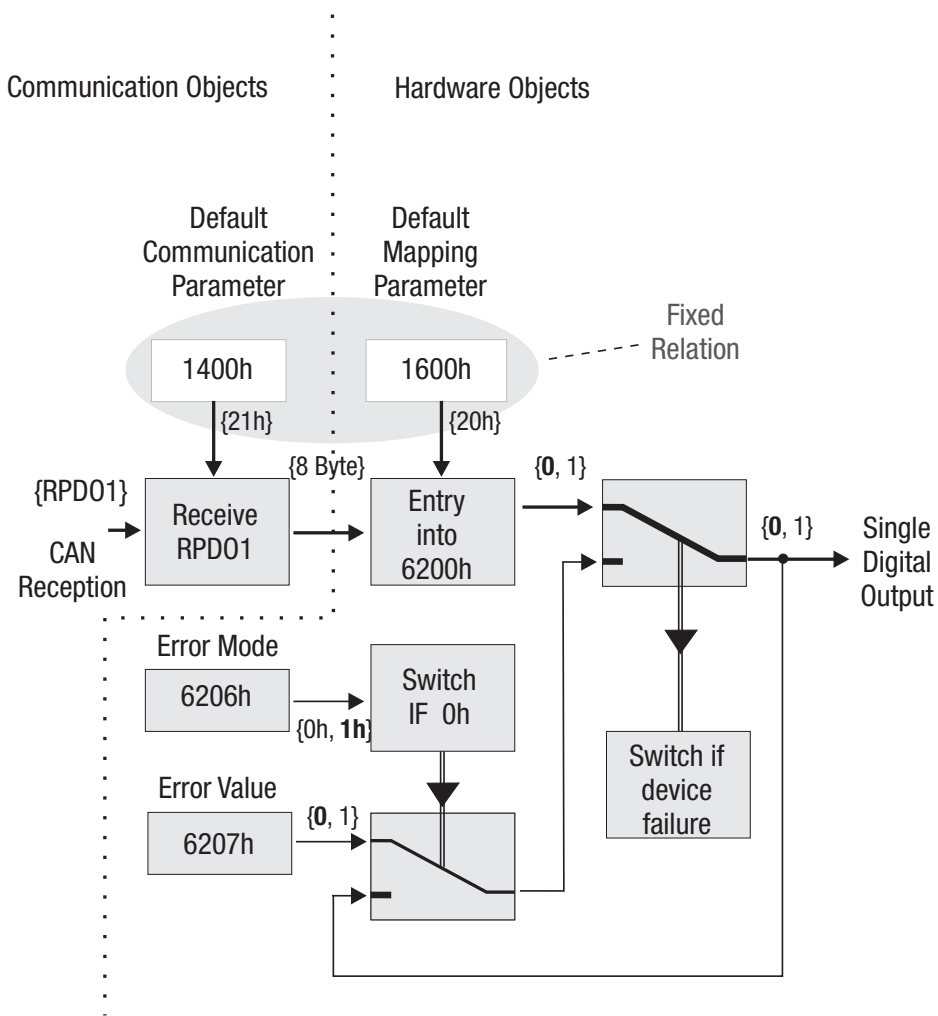

6.2.1 Object 6200_{hex} – Write Output 8 Bit

The object presents the values for the digital output modules in 8-bit groups.
A total of 36 groups (each 8 bit) can be displayed (288 digital output channels).

PDO mapping of this object is always executed by default and automatically for the first 8 sub-indexes. This corresponds to 64 digital output channels. If more than 64 output channels are present, then the PDO-mapping must be carried out by the user.

Table 72:
Object 6200_{hex}

Feature	Description/ Value
Name	Write Output 8 Bit
Object code	ARRAY
PDO mapping	Yes
Sub-index	00 _{hex}
Data type	Unsigned8
Access	ro
Default value, BLxx	No
Sub-index	01 _{hex} to 24 _{hex}
Data type	Unsigned8
Access	rw
Default value, BLxx	0

6.2.2 Object 6206_{hex} – Error Mode Output 8 Bit

The object defines values in 8-bit groups.

A total of 36 groups (each 8 bit) can be displayed (288 digital output channels).

It defines (for each digital output channel) whether or not the output should take on a substitute value in the event of an error.

The following applies:

- 0 The output maintains its value if an error occurs.
- 1 The output is set to a substitute value if an error occurs.

The substitute values for the digital output channels are defined by the Error state output object (e.g. 6207_{hex}).

Table 73:
Object 6206_{hex}

Feature	Description/ Value
Name	Error Mode Output 8 Bit
Object code	ARRAY
PDO mapping	No
Sub-index	00 _{hex}
Data type	Unsigned8
Access	ro
Default value, BLxx	No
Sub-index	01 _{hex} to 24 _{hex}
Data type	Unsigned8
Access	rw
Default value, BLxx	FF _{hex}

6.2.3 Object 6207_{hex} – Error State Output 8 Bit

The object defines values in 8-bit groups. A total of 36 groups (each 8 bit) can be displayed (288 digital output channels).

A substitute value is assigned to each analog channel. The substitute values will only be sent in case of an error, object Error Mode Output (6206_{hex}) is set to "1" for the respective channel.

Substitute values:

- 0 The output will be switched off if an error occurs.
- 1 The output will be switched on if an error occurs.

Table 74:
Object 6207_{hex}

Feature	Description/ Value
Name	Error State Output 8 Bit
Object code	ARRAY
PDO mapping	No
Sub-index	00 _{hex}
Data type	Unsigned8
Access	ro
Default value, BLxx	No
Sub-index	01 _{hex} to 24 _{hex}
Data type	Unsigned8
Access	rw
Default value, BLxx	00 _{hex}

6.2.4 Object 6220_{hex} – Write Output Bit (1 to 128), Object 6221_{hex} – Write Output Bit (129 to 256), Object 6222_{hex} – Write Output Bit (257 to 288)

The objects defined the values bit-wise.

Each sub-index for these objects is a Boolean value.

A total of 128 bits can be represented (128 digital output channels).

If more than 128 output channels are present, then object 6221_{hex} is used.

If more than 256 output channels are present, then object 6222_{hex} is used.

Since the number of digital output channels in a station is limited to 288, it is not possible to make use of the complete range of the array in object 6222_{hex}.

Table 75:
Objected
6220_{hex}
6221_{hex} 6222_{hex}

Feature	Description/ Value
Name	Write Output Bit
Object code	ARRAY
PDO mapping	Yes
Sub-index	00 _{hex}
Data type	Unsigned8
Access	ro
Default value, BLxx	No

Table 75:
Objected
6220_{hex}
6221_{hex} 6222_{hex}

Feature	Description/ Value
Sub-index	01 _{hex} to 80 _{hex}
Data type	Boolean
Access	rw
Default value, BLxx	0

6.2.5 Object 6250_{hex} – Error Mode Output Bit (1 to 128), Object 6251_{hex} – Error Mode Output Bit (129 to 256), Object 6252_{hex} – Error Mode Output Bit (257 to 288)

The objects define the values bit-wise. Each sub-index for these objects is a Boolean value.

A total of 128 bits can be represented (128 digital output channels).

If more than 128 output channels are present, then object 6251_{hex} is used. If more than 256 output channels are present, then object 6252_{hex} is used.

Since the number of digital output channels in a station is limited to 288, it is not possible to make use of the complete range of the array in object 6252_{hex}.

It defines (for each digital output channel) whether or not the output should take on a substitute value in the event of an error. The following applies:

- 0 The output maintains its value if an error occurs.
- 1 The output is set to a substitute value if an error occurs.

The substitute values for the digital output channels are defined by the Error state output objects (e.g. 6260_{hex}, 6261_{hex} and 6262_{hex}).

Table 76:
Objected
6250_{hex}
6251_{hex} 6252_{hex}

Feature	Description/ Value
Name	Error Mode Output Bit
Object code	ARRAY
PDO mapping	No
Sub-index	00 _{hex}
Data type	Unsigned8
Access	ro
Default value, BLxx	No
Sub-index	01 _{hex} to 80 _{hex}
Data type	Boolean
Access	rw
Default value, BLxx	1

6.2.6 Object 6260_{hex} – Error State Output Bit (1 to 128), Object 6261_{hex} – Error State Output Bit (129 to 256), Object 6262_{hex} – Error State Output Bit (257 to 288)

The objects define the values bit-wise. Each sub-index for these objects is a Boolean value.

A total of 128 bits can be represented (128 digital output channels).

If more than 128 output channels are present, then object 6261_{hex} is used. If more than 256 output channels are present, then object 6262_{hex} is used.

Since the number of digital output channels in a station is limited to 288, it is not possible to make use of the complete range of the array in object 6262_{hex}.

A substitute value is assigned to each analog channel. The substitute values will only be sent in case of an error, object Error Mode Output object (62506250_{hex}, 6251_{hex} and 6252_{hex}) is set to "1" for the respective channel.

Substitute values:

- 0 The output will be switched off if an error occurs.
- 1 The output will be switched on if an error occurs.

<i>Table 77: Objected 6260_{hex} 6261_{hex} 6262_{hex}</i>	Feature	Description/ Value
	Name	Error State Output Bit
	Object code	ARRAY
	PDO mapping	No
	Sub-index	00 _{hex}
	Data type	Unsigned8
	Access	ro
	Default value, BLxx	No
	Sub-index	01 _{hex} to 80 _{hex}
	Data type	Boolean
	Access	rw
	Default value, BLxx	0

6.2.7 Object 6300_{hex} – Write Output 16 Bit

The object presents the values for the digital output modules in 16-bit groups. A total of 18 groups (each 16 bit) can be displayed (288 digital output channels).

Table 78:
Object 6300_{hex}

Feature	Description/ Value
Name	Write Output 16 Bit
Object code	ARRAY
PDO mapping	Yes
Sub-index	00 _{hex}
Data type	Unsigned8
Access	ro
Default value, BLxx	No
Sub-index	01 _{hex} to 12 _{hex}
Data type	Unsigned16
Access	rw
Default value, BLxx	0000 _{hex}

6.2.8 Object 6306_{hex} – Error Mode Output 16 Bit

The object defines values in 16-bit groups. A total of 18 groups (each 16 bit) can be displayed (288 digital output channels).

It defines (for each digital output channel) whether or not the output should take on a substitute value in the event of an error. The following applies:

- 0 The output maintains its value if an error occurs.
- 1 The output is set to a substitute value if an error occurs.

The substitute values for the digital output channels are defined by the Error state output object (e.g. 6307_{hex}).

Table 79:
Object 6306_{hex}

Feature	Description/ Value
Name	Error Mode Output 16 Bit
Object code	ARRAY
PDO mapping	No
Sub-index	00 _{hex}
Data type	Unsigned8
Access	ro
Default value, BLxx	No

Table 79:
Object 6306_{hex}

Feature	Description/ Value
Sub-index	01 _{hex} to 12 _{hex}
Data type	Unsigned16
Access	rw
Default value, BLxx	FFFF _{hex}

6.2.9 Object 6307_{hex} – Error State Output 16 Bit

The object defines values in 16-bit groups. A total of 18 groups (each 16 bit) can be displayed (288 digital output channels).

A substitute value is assigned to each analog channel. The substitute values will only be sent in case of an error, object Error Mode Output (6306_{hex}) is set to "1" for the respective channel.

Substitute values:

- 0 The output will be switched off if an error occurs.
- 1 The output will be switched on if an error occurs.

Table 80:
Object 6307_{hex}

Feature	Description/ Value
Name	Error State Output 16 Bit
Object code	ARRAY
PDO mapping	No
Sub-index	00 _{hex}
Data type	Unsigned8
Access	ro
Default value, BLxx	No
Sub-index	01 _{hex} to 12 _{hex}
Data type	Unsigned16
Access	rw
Default value, BLxx	0000 _{hex}

6.2.10 Object 6320_{hex} – Write Output 32 Bit

The object presents the values for the digital output modules in 32-bit groups.
 A total of 9 groups (each 32 bit) can be displayed (288 digital output channels).

Table 81:
 Object 6320_{hex}

Feature	Description/ Value
Name	Write Output Bit
Object code	ARRAY
PDO mapping	Yes
Sub-index	00 _{hex}
Data type	Unsigned8
Access	ro
Default value, BLxx	No
Sub-index	01 _{hex} to 09 _{hex}
Data type	Unsigned32
Access	rw
Default value, BLxx	0000 0000 _{hex}

6.2.11 Object 6326_{hex} – Error Mode Output 32 Bit

The object defines values in 32-bit groups. A total of 9 groups (each 32 bit) can be displayed (288 digital output channels).

It defines (for each digital output channel) whether or not the output should take on a substitute value in the event of an error. The following applies:

- 0 The output maintains its value if an error occurs.
- 1 The output is set to a substitute value if an error occurs.

The substitute values for the digital output channels are defined by the Error state output object (e.g. 6327_{hex}).

Table 82:
Object 6326_{hex}

Feature	Description/ Value
Name	Error Mode Output 32 Bit
Object code	ARRAY
PDO mapping	No
Sub-index	00 _{hex}
Data type	Unsigned8
Access	ro
Default value, BLxx	No
Sub-index	01 _{hex} to 09 _{hex}
Data type	Unsigned32
Access	rw
Default value, BLxx	FFFF FFFF _{hex}

6.2.12 Object 6327_{hex} – Error State Output 32 Bit

The object defines values in 32-bit groups. A total of 9 groups (each 32 bit) can be displayed (288 digital output channels).

A substitute value is assigned to each analog channel. The substitute values will only be sent in case of an error, object Error Mode Output (6326_{hex}) is set to "1" for the respective channel.

Substitute values:

- 0 The output will be switched off if an error occurs.
- 1 The output will be switched on if an error occurs.

Table 83:
Object 6327_{hex}

Feature	Description/ Value
Name	Error State Output 32 Bit
Object code	ARRAY
PDO mapping	No
Sub-index	00 _{hex}
Data type	Unsigned8
Access	ro
Default value, BLxx	No
Sub-index	01 _{hex} to 09 _{hex}
Data type	Unsigned32
Access	rw
Default value, BLxx	0000 0000 _{hex}

7 Objects for digital combi modules

7.1	Digital combi modules BLxx	2
7.2	General object overview for digital combi modules	2

7.1 Digital combi modules BLxx

The objects are used in the following modules:

*Table 84:
BLxx - digital
combi modules*

Product family	Module
BL67	BL67-4DI-4DO-PD
	BL67-8XSG-PD
BLC	miscellaneous

7.2 General object overview for digital combi modules



Note

The objects for digital combi modules correspond to those of the digital in- and output modules. Please read [chapter 5, Objects for digital input modules](#) and [chapter 6, Objects for digital output modules](#).

The parameterization of the combi modules is realized through the manufacturer specific objects described in the following.

*Table 85:
General object
overview for
digital combi
modules*

Object	Name	page
Input objects		
6000 _{hex}	Read Input 8 Bit	page 5-4
6020 _{hex} , 6021 _{hex} , 6022 _{hex}	Read Input 8 Bit	page 5-5
6100 _{hex}	Read Input 16 Bit	page 5-6
6120 _{hex}	Read Input 32 Bit	page 5-6
Output objects		
6200 _{hex}	Write Output 8 Bit	page 6-4
6206 _{hex}	Error Mode Output 8 Bit	page 6-5
6207 _{hex}	Error State Output 8 Bit	page 6-6
6220 _{hex} , 6221 _{hex} , 6222 _{hex}	Write Output 8 Bit	page 6-7
6250 _{hex} , 6251 _{hex} , 6252 _{hex}	Error Mode Output Bit	page 6-8
6260 _{hex} , 6261 _{hex}	Error State Output Bit (1 to 128), Bit (129 to 256)	page 6-9
6300 _{hex}	Write Output 16 Bit	page 6-10
6306 _{hex}	Error Mode Output 16 Bit	page 6-10
6307 _{hex}	Error State Output 16 Bit	page 6-11
6320 _{hex}	Write Output 32 Bit	page 6-12
6326 _{hex}	Error Mode Output 32 Bit	page 6-13
6327 _{hex}	Error State Output 32 Bit	page 6-14



Parameter object

3064_{hex}

XBIParam Dword

[page 14-10](#)

8 Objects for analog input modules

8.1	Analog input modules BLxx.....	2
8.2	General object overview for analog input modules.....	2
8.2.1	Object 5420 _{hex} – Manu Spec Analog Input Range	3
	– Analog input modules, current	4
	– Analog input modules, voltage	4
	– analog input modules, current/ voltage	5
	– Analog input modules, PT/Ni	5
	– Analog input modules, 2AI-THERMO/TC	6
	– Analog input modules, 4AI-TC	7
	– Analog input modules, -8AI-U/I-4PT/NI	8
8.2.2	Object 6401 _{hex} – Read Analog Input 16 Bit	10
8.2.3	Object 6421 _{hex} – Analog Input Interrupt Trigger Selection	11
8.2.4	Object 6422 _{hex} – Analog Input Interrupt Source	13
8.2.5	Object 6423 _{hex} – Analog Input Global Interrupt Enable	14
8.2.6	Object 6424 _{hex} – Analog Input Interrupt Upper Limit Integer	14
8.2.7	Object 6425 _{hex} – Analog Input Interrupt Lower Limit Integer	15
8.2.8	Object 6426 _{hex} – Analog Input Interrupt Delta Unsigned	15
8.2.9	Object 6427 _{hex} – Analog Input Interrupt Negative Delta Unsigned	16
8.2.10	Object 6428 _{hex} – Analog Input Interrupt Positive Delta Unsigned	16

8.1 Analog input modules BLxx

The objects are used in the following modules:

*Table 86:
BLxx - analog
input modules*

Product family	Module
BL20	BL20-xAI-I(0/4...20MA)
	BL20-xAI-U(-10/0...+10VDC)
	BL20-2AI-PT/NI-2/3
	BL20-2AI-THERMO-PI
	BL20-4AI-U/I
	BL20-E-8AI-U/I-4PT/NI
	BL20-2AIH-I
BL67	BL67-2AI-I
	BL67-2AI-V
	BL67-2AI-PT
	BL67-2AI-TC
	BL67-4AI-V/I
BLC	miscellaneous

8.2 General object overview for analog input modules

*Table 87:
General object
overview for
analog input
modules*

Object	Name	page
5420 _{hex}	Manu Spec Analog Input Range	page 8-3
6401 _{hex}	Read analog Input 16 Bit	page 8-10
6421 _{hex}	Analog Input Interrupt Trigger Selection	page 8-11
6422 _{hex}	Analog Input Interrupt Source	page 8-13
6423 _{hex}	Analog Input Global Interrupt Enable	page 8-14
6424 _{hex}	Analog Input Interrupt Upper Limit Integer	Seite 8-14
6425 _{hex}	Analog Input Interrupt Lower Limit Integer	Seite 8-15
6426 _{hex}	Analog Input Interrupt Delta Unsigned	Seite 8-15
6427 _{hex}	Analog Input Interrupt Negative Delta Unsigned	Seite 8-16
6428 _{hex}	Analog Input Interrupt Positive Delta Unsigned	Seite 8-16

The following figure shows the relationship between the analog input objects for an 16-bit access:

Figure7:
Relationship
between the
analog output
objects
(according to CiA
Draft Standard
DS401)

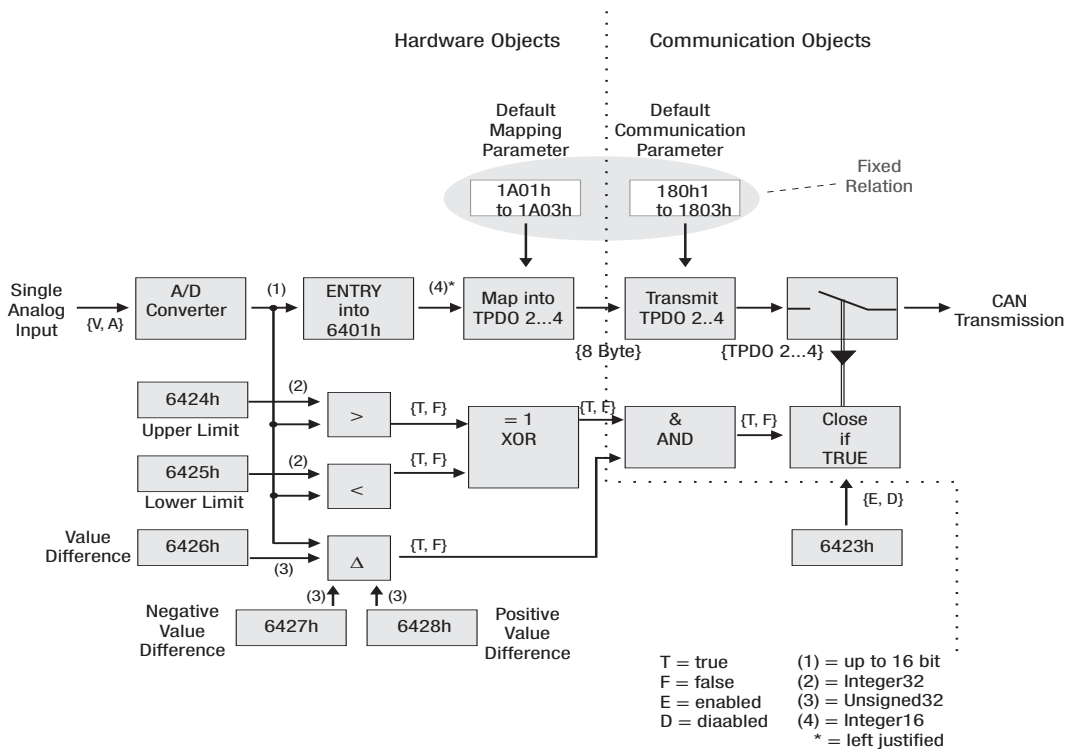

8.2.1 Object 5420_{hex} – Manu Spec Analog Input Range

The object defines the parameters of the analog input channels.

Write accesses initiate a parameter update via the internal BLxx-module bus.

The parameter is stored as a non-volatile parameter in the gateway and is restored with every node reset.

The Sub-indices 01_{hex} – 8E_{hex} define the parameters for the analog input channel 1 to 142.

Table 88:
Object 5420_{hex}

Feature	Description/ Value
Name	Manu Spec Analog Input Range
Object code	ARRAY
PDO mapping	No
Sub-index	00 _{hex}
Data type	Unsigned8
Access	ro
Default value, BLxx	No
Sub-index	01 _{hex} bis 8E _{hex}

Table 88:
Object 5420_{hex}

Feature	Description/ Value
Data type	Unsigned16
Access	rw
Default value, BLxx	No

The structure of the 2 bytes of parameter data depends on the module concerned.

A sub-index is assigned for **each** channel. The following explains the structure for each module type.

Analog input modules, current

Table 89:
Parameters,
analog input
modules,
current

ADefault-
setting

Byte	Bit	Parameters	Value/ meaning
n	0	current mode	0 = 0...20 mA A 1 = 4...20 mA
	1	Value representation	0 = Integer (15 bit + sign) A 1 = reserved
	2	Diagnostic	0 = release A 1 = block
	3	Channel x	0 = activate A 1 = deactivate
	4 to 7	reserved	

Analog input modules, voltage

Table 90:
Parameter,
analog
input modules,
voltage

ADefault-
setting

Byte	Bit	Parameters	Value/ meaning
n	0	voltage mode	0 = 0...10 V A 1 = -10...10 V
	1	Value representation	0 = Integer (15 bit + sign) A 1 = reserved
	2	Diagnostic	0 = release A 1 = block
	3	Channel x	0 = activate A 1 = deactivate
	4 to 7	reserved	

analog input modules, current/ voltage

Table 91: Parameter, analog input modules, current/voltage
ADefault-setting

Byte	Bit	Parameters	Value/ meaning
n	0	Range	0 = 0...10 V/0...20 mA A 1 = -10...10 V/4...20 mA
	1	Value representation	0 = Integer (15 bit + sign) A 1 = reserved
	2	Diagnostic	0 = release A 1 = block
	3	Channel x	0 = activate A 1 = deactivate
	4	Operation mode	0 = voltage A 1 = current
	5 to 7	reserved	

Analog input modules, PT/Ni

Table 92: Parameter, analog input modules, PT/Ni
ADefault-setting

Byte	Bit	Parameters	Value/ meaning
n	0	Mains suppression	0 = 50 Hz A 1 = 60 Hz
	1	Value representation	0 = Integer (15 bit + sign) A 1 = reserved
	2	Diagnostic	0 = release A 1 = block
	3	Channel x	0 = activate A 1 = deactivate
	4 to 7	Element	0000 = Pt100, -200...850 °C A 0001 = Pt100, -200...150 °C 0010 = Ni100, -60...250 °C 0011 = Ni100, -60...150 °C 0100 = Pt200, -200...850 °C 0101 = Pt200, -200...150 °C 0110 = Pt500, -200...850 °C 0111 = Pt500, -200...150 °C 1000 = Pt1000, -200...850 °C 1001 = Pt1000, -200...150 °C 1010 = Ni1000, -60...250 °C 1011 = Ni1000, -60...150 °C 1100 = resistance, 0...100 Ω 1101 = resistance, 0...200 Ω 1110 = resistance, 0...400 Ω 1111 = resistance, 0...1000 Ω
n + 1	0	Measurement mode	0 = 2-wire A 1 = 3-wire

Analog input modules, 2AI-THERMO/TC

Table 93:
Parameter,
analog
input modules,
4AI-TC

Byte	Bit	Parameters	Value/ meaning
n	0	Cold junction sensor	0 = Pt1000 A 1 = Pt100
	1	Value representation	0 = Integer (15 bit + sign) A 1 = reserved
	2	Diagnostic	0 = release A 1 = block
	3	Channel x	0 = activate A 1 = deactivate
	6 to 4	Element	0000 = Type K, -270...1370 °C 0001 = Type B, +100...1820 °C 0010 = Type E, -270...1000 °C 0011 = Type J, -210...1200 °C 0100 = Type N, -270...1300 °C 0101 = Type R, -50...1760 °C 0110 = Type S, -50...1540 °C 0111 = Type T, -270...400 °C 1000 = ±50 mV 1001 = ±100 mV 1010 = ±500 mV 1011 = ±1000 mV 1100 = Type J, -454... 2498 °F 1101 = Type J, -346... 2192 °F 1110 = Type C, 0...2320 °C 1111 = Type G, 0...2320 °C
	7	reserved	

ADefault-
setting

Analog input modules, 4AI-TC

<i>Table 94: Parameter, analog input modules, THERMO</i>	Byte	Bit	Parameters	Value/ meaning
	n	0	Mains suppression	0 = 50 Hz A 1 = 60 Hz
		1	Value representation	0 = Integer (15 bit + sign) A 1 = reserved
A Default-setting		2	Diagnostic	0 = release A 1 = block
		3	Channel x	0 = activate A 1 = deactivate
		6 to 4	Element	0000 = Type K, -270...1370 °C 0001 = Type B, +100...1820 °C 0010 = Type E, -270...1000 °C 0011 = Type J, -210...1200 °C 0100 = Type N, -270...1300 °C 0101 = Type R, -50...1760 °C 0110 = Type S, -50...1540 °C 0111 = Type T, -270...400 °C 1000 = ±50 mV 1001 = ±100 mV 1010 = ±500 mV 1011 = ±1000 mV
		7	reserved	

Analog input modules, -8AI-U/I-4PT/NI

Table 95:	Assignment		Parameters	Meaning
<i>Module parameters BL20-E-8AI-U/I-4PT/NI</i>	Byte	Bit		
A Default settings	0 - 7	0 - 5	Operation mode Kx	000000 = Voltage 0...10 V DC Standard A
B In Pt, Ni and R-, measurement, only the first of the used channels is parameterized (channel 1,3,5,7).. The parameterization of the second channel will be ignored.				000001 = Voltage -10...10 V DC Standard
				000010 = Voltage 0...10 V DC PA (NE 43)
				000011 = Voltage -10...10 V DC PA (NE 43)
				000100 = Voltage -10...10 V DC Ext. range
				000101 = Voltage 0...10 V DC Ext. range
				001000 = Current 0 ... 20 mA Standard
				001001 = Current 4 ... 20 mA Standard
				001010 = Current 0 ... 20 mA PA (NE 43)
				001011= Current 4 ... 20 mA PA (NE 43)
				001100 = Current 0 ... 20 mA Ext. range
				001001 = Current 4 ... 20 mA Ext. range
				010000 = Pt100-200 °C ... 850 °C, 2-wire B
				010001 = Pt 100-200 °C ... 150 ? 2-wire
				010010 = Pt200-200 °C ... 850 °C 2-wire
				010011 = Pt200-200 °C ... 150 °C 2-wire
				010100 = Pt500-200 °C ... 850 °C 2-wire
				010101 = Pt500-200 °C ... 150 °C 2-wire
				010110 = Pt1000-200 °C ... 850 °C 2-wire
				010111 = Pt1000-200 °C ... 150 °C 2-wire
				011000 = Pt100-200 °C ... 850 °C 3-wire
				011001 = Pt100-200 °C ... 150 °C 3-wire
				011010 = Pt200-200 °C ... 850 °C 3-wire
				011011 = Pt200-200 °C ... 150 °C 3-wire
				011100 = Pt500-200 °C ... 850 °C 3-wire
				011101 = Pt500-200 °C ... 150 °C 3-wire
				011110 = Pt1000-200 °C ... 850 °C 3-wire
				011111 = Pt1000-200 °C ... 150 °C 3-wire
				100000 = Ni100, -60°C..150°C, 2-wire
				100001 = Ni100, -60°C..150°C, 2-wire

Table 95:
Module parameters BL20-E-8AI-U/I-4PT/NI

Assignment		Parameters	Meaning
Byte	Bit		
0 - 7	0 - 5	Operation mode Kx	100010 = Ni1000, -60°C..250°C, 2-wire
			100011 = Ni1000, -60°C..250°C, 2-wire
			100100 = NI1000TK5000, -60 °C .. 150°C, 2-wire
			100101 = Ni100, -60°C..150°C, 3-wire
			100110 = Ni100, -60°C..150°C, 3-wire
			100111 = Ni1000, -60°C..250°C, 3-wire
			101010 = Ni1000, -60°C..250°C, 3-wire
			101001 = NI1000TK5000, -60 °C .. 150°C, 3-wire
			110000 = resistance, 0 ... 250 W
			110001 = resistance, 0 ... 400 W
			110010 = resistance, 0 ... 800 W
			110011 = resistance, 0 ... 1000 W
			110100 = resistance, 0 ... 2000 W
			110101 = channel not active
0 - 7	6	Value representation Kx	Integer (15bit + sign) A A 12 bit (left-justified)
	7	Diagnostic Kx	release A block

8.2.2 Object 6401_{hex} – Read Analog Input 16 Bit

The object represents the measured values for the analog input modules with 16 bits for each channel.



Attention

The process data traffic for the analog input values is not started until the object 6423_{hex} is switched from the default setting FALSE to TRUE!



Attention

the possibility of 12-bit value representation (left-justified) is not useful for CANopen since all reference values (upper limit, lower limit) must be defined with 16 bits.

Table 96:
Object 6401_{hex}

Feature	Description/ Value
Name	Read Analog Input 16 Bit
Object code	ARRAY
PDO mapping	Yes
Sub-index	00 _{hex}
Data type	Unsigned8
Access	ro
Default value, BLxx	No
Sub-index	01 _{hex} bis 8E _{hex}
Data type	Integer16
Access	ro
Default value, BLxx	No

8.2.3 Object 6421_{hex} – Analog Input Interrupt Trigger Selection



Note

Objects 6421 – 6428_{hex} can be used to control the event-triggered transmission of the process input data. As well as these event-triggered control objects, the transmission frequency of the process input data is also controlled by means of objects 1800_{hex} to 181F_{hex}.



Attention

Object 6423_{hex} Analog Input Global Interrupt Enable, [page 8-14](#) must be used in order to enable the possibility of transmitting the process input data using an interrupt signal!

The object defines which event is to trigger the transmitting of the analog input data (TPDOs) by means of an interrupt signal.

The triggering event is defined for each input channel using a corresponding sub-index of the object.

Table 97:
Object 6421_{hex}

Feature	Description/ Value
Name	Analog Input Interrupt Trigger Selection
Object code	ARRAY
PDO mapping	No
Sub-index	00 _{hex}
Data type	Unsigned8
Access	ro
Default value, BLxx	No
Sub-index	01 _{hex} bis 8E _{hex}
Data type	Unsigned8
Access	rw
Default value	
- BL20	Firmware: ≤ version 4.02/ 2.02 = 0 ≥ version 4.02/ 2.02 = 7
- BL67/BLCCO	7

Table 98:
Structure of the
Sub-Index 01_{hex}
to 8E_{hex}

AThe upper/lower limit values and the delta values are defined using the objects 6424_{hex}, 6425_{hex}, 6426_{hex}, 6427_{hex} and 6428_{hex}.

Bit	Trigger event
0	1 „upper limit“ A exceeded A - the value at the input has exceeded the upper limit.
1	1 Input below „lower limit“ A - the value at the input is below the lower limit.
2	1 Input changed by more than „Delta“ A - the value at the input has changed by a defined "Delta" value.
3	1 Input reduced by more than „negative delta“ A - the value at the input has reduced by a defined "Delta" value.
4	1 Input increased by more than „positive delta“ A - the value at the input has increased by a defined "Delta" value.
5 – 7	reserved



Note

Several bits can be set simultaneously so that the transmitting of the input process data can be triggered by several events.



Note

The transmitting of the analog input data (TPDOs) by means of an interrupt signal is triggered repeatedly with every change of the analog input value if the value stays above the upper limit or below the lower limit.

If another triggering event occurs at the same time (e.g. increase by "Delta value"), the repeated transmitting is aborted.

8.2.4 Object 6422_{hex} – Analog Input Interrupt Source

The object indicates if an analog input channel has fulfilled a condition for triggering an interrupt signal.

The conditions were defined with object 6421_{hex}. If a condition for triggering an interrupt signal on a channel is fulfilled, the corresponding bit is set to 1. The corresponding bits for channels 0 to 31 are set in sub-index 01_{hex} and the bits for channels 32 to 63 in sub-index 02_{hex} etc.

The bits can be read using a SDO. The reading causes a bit reset to "0".

Table 99:
Object 6422_{hex}

Feature	Description/ Value
Name	Analog Input Interrupt Source
Object code	ARRAY
PDO mapping	No
Sub-index	00 _{hex}
Data type	Unsigned8
Access	ro
Default value, BLxx	No
Sub-index	01 _{hex} to 08 _{hex}
Data type	Unsigned32
Access	ro
Default value, BLxx	00 _{hex}

8.2.5 Object 6423_{hex} – Analog Input Global Interrupt Enable

With this object the possibility of generating an interrupts signal will be enabled. If the value is set as defined per default from FALSE to TRUE, than sending the analog input values (TPDOs) can be triggered using an interrupt signal..

Table 100:
Object 6423_{hex}

Feature	Description/ Value
Name	Analog Input Global Interrupt Enable
Object code	VAR
PDO mapping	No
Sub-index	00 _{hex}
Data type	Boolean
Access	rw
Default value, BLxx	FALSE

8.2.6 Object 6424_{hex} – Analog Input Interrupt Upper Limit Integer

The object 6424_{hex} defines the value for an upper limit.

Values above this "upper limit" can be defined as the condition for generating an interrupt signal.

→ „6421_{hex} Analog input interrupt trigger selection“, [page 8-11](#).

Table 101:
Object 6424_{hex}

Feature	Description/ Value
Name	Analog Input Interrupt Upper Limit Integer
Object code	ARRAY
PDO mapping	No
Sub-index	00 _{hex}
Data type	Unsigned8
Access	ro
Default value, BLxx	No
Sub-index	01 _{hex} bis 8E _{hex}
Data type	Integer32
Access	rw
Default value, BLxx	00000000 _{hex}

8.2.7 Object 6425_{hex} – Analog Input Interrupt Lower Limit Integer

The object 6425_{hex} defines the value for an lower limit.

Values below this "lower limit" can be defined as the condition for generating an interrupt signal. → „6421_{hex} Analog input interrupt trigger selection“, [page 8-11](#).

Table 102:
Object 6425_{hex}

Feature	Description/ Value
Name	Analog Input Interrupt Lower Limit Integer
Object code	ARRAY
PDO mapping	No
Sub-index	00 _{hex}
Data type	Unsigned8
Access	ro
Default value, BLxx	No
Sub-index	01 _{hex} bis 8E _{hex}
Data type	Integer32
Access	rw
Default value, BLxx	00000000 _{hex}

8.2.8 Object 6426_{hex} – Analog Input Interrupt Delta Unsigned

The object 6426_{hex} defines a Delta value.

Values that deviate from the input value by this "Delta value" can be defined as the condition for generating an interrupt signal. → „6421_{hex} Analog input interrupt trigger selection“, [page 8-11](#).

Table 103:
Object 6426_{hex}

Feature	Description/ Value
Name	Analog Input Interrupt Delta Unsigned
Object code	ARRAY
PDO mapping	No
Sub-index	00 _{hex}
Data type	Unsigned8
Access	ro
Default value, BLxx	No
Sub-index	01 _{hex} bis 8E _{hex}
Data type	Unsigned32
Access	rw
Default value, BLxx	00000000 _{hex}

8.2.9 Object 6427_{hex} – Analog Input Interrupt Negative Delta Unsigned

The object 6427_{hex} defines a Delta value.

Values with a **negative** deviation of the input value by more than this "Delta value" can be defined as the condition for generating an interrupt signal.

→ „6421_{hex} Analog input interrupt trigger selection“, [page 8-11](#).

Table 104:
Object 6427_{hex}

Feature	Description/ Value
Name	Analog Input Interrupt Negative Delta Unsigned
Object code	ARRAY
PDO mapping	No
Sub-index	00 _{hex}
Data type	Unsigned8
Access	ro
Default value, BLxx	No
Sub-index	01 _{hex} bis 8E _{hex}
Data type	Unsigned32
Access	rw
Default value, BLxx	0000 0000 _{hex}

8.2.10 Object 6428_{hex} – Analog Input Interrupt Positive Delta Unsigned

The object 6428_{hex} defines a Delta value.

Values with a **positive** deviation of the input value by more than this "Delta value" can be defined as the condition for generating an interrupt signal.

→ „6421_{hex} Analog input interrupt trigger selection“, [page 8-11](#).

Table 105:
Object 6428_{hex}

Feature	Description/ Value
Name	Analog Input Interrupt Positive Delta Unsigned
Object code	ARRAY
PDO mapping	No
Sub-index	00 _{hex}
Data type	Unsigned8
Access	ro
Default value, BLxx	No
Sub-index	01 _{hex} bis 8E _{hex}

Table 105:
Object 6428_{hex}

Feature	Description/ Value
Data type	Unsigned32
Access	rw
Default value, BLxx	00000000 _{hex}

9 Objects for analog output modules

9.1	Analog output modules BLxx	2
9.2	General object overview for analog output modules	2
9.2.1	Object 5440 _{hex} – Manu Spec Analog Output Range	4
	– Analog output modules, current	4
	– Analog output modules, voltage.....	5
	– analog output modules, current/ voltage	5
9.2.2	Object 6411 _{hex} – Write Analog Output 16 Bit	6
9.2.3	Object 6443 _{hex} - Analog Output Error Mode	7
9.2.4	Object 6444 _{hex} – Analog Output Error State	8

9.1 Analog output modules BLxx

The objects are used in the following modules:

*Table 106:
BLxx - analog
output modules*

Product family	Module
BL20	BL20-xAO-I(0/4...20MA)
	BL20-2AO-U(-10/0...+10VDC)
	BL20-E-4AO-U/I
	BL20-2AOH-I
BL67	BL67-2AO-I
	BL67-2AO-V
	BL67-4AO-V
BLC	miscellaneous

9.2 General object overview for analog output modules

*Table 107:
General object
overview for
analog output
modules*

Object	Name	page
5440 _i	Manu Spec Analog Output Range	page 9-4
6411 _{hex}	Write Analog Output 16 Bit	page 9-6
6443 _{hex}	Analog Output Error Mode	page 9-6
6444 _{hex}	Analog Output Error State	page 9-8

The following figure shows the relationship between the analog output objects for an 16-bit access:

Figure8:
Relationship
between the
objects for analog
output modules
(according to CiA
Draft Standard
401)

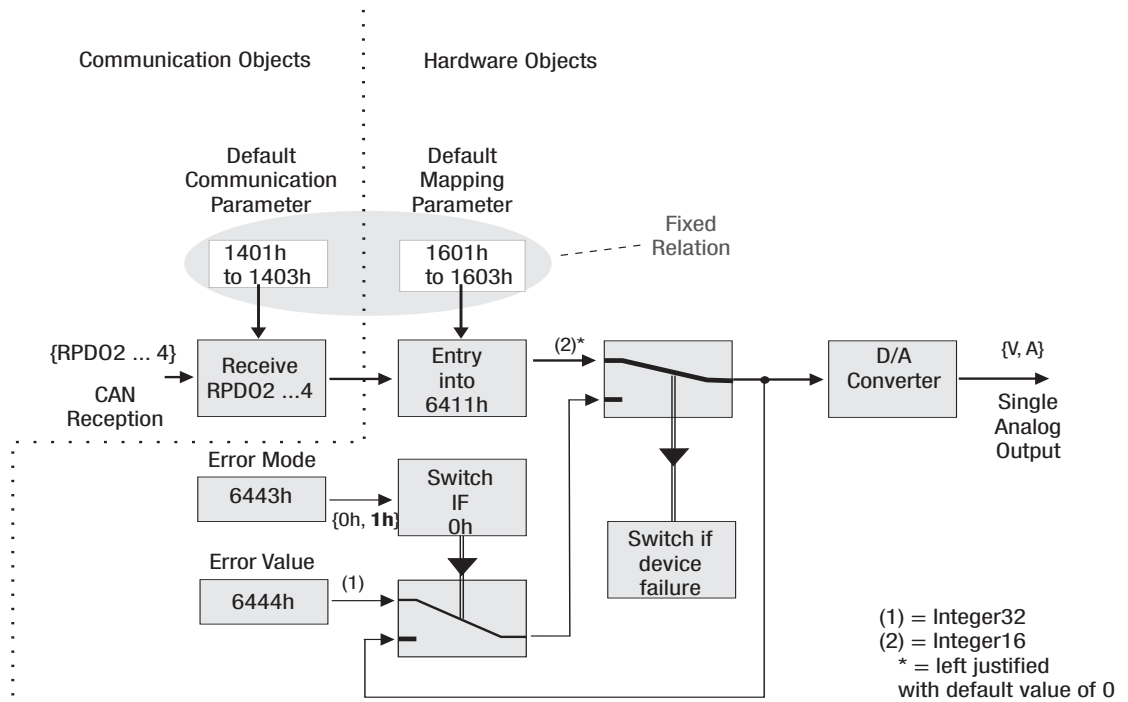

9.2.1 Object 5440_{hex} – Manu Spec Analog Output Range

The object defines the parameters of the analog output channels. Write accesses initiate a parameter update via the internal BLxx-module bus.

The parameter is stored as a non-volatile parameter in the gateway and is restored with every node reset.

The Sub-indices 01_{hex} – 8E_{hex} define the parameters for the analog output channels 1 to 142.

Table 108:
Object 5440_{hex}

Feature	Description/ Value
Name	Manu Spec Analog Output Range
Object code	ARRAY
PDO mapping	No
Sub-index	00 _{hex}
Data type	Unsigned8
Access	ro
Default value, BLxx	No
Sub-index	01 _{hex} – 8E _{hex}
Data type	Unsigned16
Access	rw
Default value, BLxx	No

The structure of the 2 bytes of parameter data depends on the module concerned.

A sub-index is assigned for each channel. The following explains the structure for each module type.

Analog output modules, current

Table 109:
Parameter,
analog
Analog output
modules,
current
ADefault-
setting

Byte	Bit	Parameters	Value/ meaning
n	0	Current mode	0 = 0...20 mA A 1 = 4...20 mA
	1	Value representation	0 = Integer (15 bit + sign) A 1 = reserved
	3	Channel x	0 = activate A 1 = deactivate
n + 1 and n + 2		substitute value A1	The substitute value will be transmitted if the respective parameters of the gateway have been set to "output substitute value".

Analog output modules, voltage

Table 110: Parameters, analog output modules, voltage
ADefault-setting

Byte	Bit	Parameters	Value/ meaning
n	0	Current mode	0 = 0...10 V A 1 = -10...10 V
	1	Value representation	0 = Integer (15 bit + sign) A 1 = reserved
	3	Channel x	0 = activate A 1 = deactivate
n + 1 and n + 2		substitute value A1	The substitute value will be transmitted if the respective parameters of the gateway have been set to "output substitute value".

analog output modules, current/ voltage

Table 111: Parameters, analog output modules, current/voltage
ADefault-setting

Byte	Bit	Parameters	Value/ meaning	
n	0 - 3	voltage	0000 = -10...10 V DC Std A 0001 = 0...10 V DC Std 0010 = -10...10 V DC PA (NE 43) 0011 = 0...10 V DC PA (NE 43) 0100 = -10...10 V DC Ext. range 0101 = 0...10 V DC Ext. range	
			current	1000 = 0 ... 20 mA Std A 1001 = 4 ... 20 mA Std 1010 = 0 ... 20 mA PA (NE 43) 1011 = 4 ... 20 mA PA (NE 43) 1100 = 0 ... 20 mA Ext. range 1101 = 4 ... 20 mA Ext. range
			deactivate	1111
			4	Value representation
	5	Diagnostics	0 = release A 1 = block	
	6+7	Behavior on module bus error Ax	00 = output substitute value 01 = hold current value	
n + 1		Substitute value A x / LOW Byte		
n + 2		Substitute value A x / HIGH Byte		

9.2.2 Object 6411_{hex} – Write Analog Output 16 Bit

The object represents the values for the analog output modules with 16 bits for each channel.

Table 112:
Object 6411_{hex}

Feature	Description/ Value
Name	Write Analog Output 16 Bit
Object code	ARRAY
PDO mapping	Yes
Sub-index	00 _{hex}
Data type	Unsigned8
Access	ro
Default value, BLxx	No
Sub-index	01 _{hex} to 8E _{hex}
Data type	Integer16
Access	rw
Default value, BLxx	00 _{hex}

9.2.3 Object 6443_{hex} - Analog Output Error Mode

It defines (for each digital output channel) whether or not the output should take on a substitute value in the event of an error. The Sub-indices 01_{hex} – 8E_{hex} define the parameters for the analog output channels 1 to 142.

The following applies:

00_{hex} The output maintains its value if an error occurs.

_{hex}The output is set to the substitute value if an error occurs.

The substitute values for the analog output channels are defined by the Analog Output Error State object (6444_{hex}).

Table 113:
Object 6443_{hex}

Feature	Description/ Value
Name	Analog Output Error Mode
Object code	ARRAY
PDO mapping	No
Sub-index	00 _{hex}
Data type	Unsigned8
Access	ro
Default value, BLxx	No
Sub-index	01 _{hex} to 8E _{hex}
Data type	Unsigned16
Access	rw
Default value, BLxx	00 _{hex}

9.2.4 Object 6444_{hex} – Analog Output Error State

A substitute value is assigned to each analog channel. The substitute values will only be sent in case of an error, object Analog Output Error Mode (6443_{hex}) is set to "01_{hex}".

The Sub-indices 01_{hex} to 8E_{hex} define the parameters for the analog output channels 1 to 142.

Table 114:
Object 6444_{hex}

Feature	Description/ Value
Name	Analog Output Error State
Object code	ARRAY
PDO mapping	No
Sub-index	00 _{hex}
Data type	Unsigned8
Access	ro
Default value, BLxx	No
Sub-index	01 _{hex} to 8E _{hex}
Data type	Unsigned16
Access	rw
Default value, BLxx	0000 0000 _{hex}

10 Objects for RS232/RS4xx modules

10.1	RSxxx modules BLxx	2
10.2	Allgemeine Objektübersicht für RS232/RS4xx-Module	2
10.2.1	Object 5600 _{hex} – RS232/RS4xx Parameters.....	2
10.2.2	Object 5601 _{hex} – RS232/RS4xx RxD	4
10.2.3	Object 5602 _{hex} – RS232/RS4xx TxD.....	7

10.1 RSxxx modules BLxx

The objects are used in the following modules:

<i>Table 115: BLxx - RSxxx modules</i>	Product family	Module
	BL20	BL20-1RS232
		BL20-1RS485/422
	BL67	BL67-1RS232
		BL67-1RS485/422
	BLC	miscellaneous

10.2 Allgemeine Objektübersicht für RS232/RS4xx-Module

<i>Table 116: General object overview for RS232/RS4xx modules</i>	Object	Name	page
	5600 _{hex}	RS232/RS4xx parameters	page 10-2
	5601 _{hex}	RS232/RS4xx RxD	page 10-4
	5602 _{hex}	RS232/RS4xx TxD	page 10-7

10.2.1 Object 5600_{hex} – RS232/RS4xx Parameters

The parameter setting of the BL20-1RSxxx module enables communication with different data terminal devices. The handshake procedure (software/hardware) can be selected. The number of data bits embedded in the telegram, the type of parity, the number of stop bits, the bit transmission rate and the XON/XOFF character used must be configured in the module with the appropriate parameters in order to adapt it to the data format of the data terminal device.

4 bytes are used for the module parameters.

<i>Table 117: Object 5600_{hex}</i>	Feature	Description
	Name	RS232/RS4xx parameters
	Object code	ARRAY
	Data type	Unsigned32
	Access	rw
	Default value	No
	PDO mapping	No

	Bit 7	Bit 6	Bit 5	Bit 4	Bit 3	Bit 2	Bit 1	Bit 0
Byte 0	Disable Diagnostics	Disable Reduced Control	X	Select RS485	Bit Rate			
Byte 1	X	X	Flow Control		Data	Parity	Stop	
Byte 2	XONChar							
Byte 3	XOFFChar							

Table 118:
Parameters
BLxx-1RSxxx
A Default-setting

Parameters	Value/ meaning
DisableDiagnostics (Diagnostics)	<p>0 = Diagnostics activated</p> <hr/> <p>1 = Diagnostics deactivated This controls the separate field bus-specific diagnostics signal - not the diagnostics signal embedded in the process input data (object 5601_{hex}).</p>
DisableReducedCtrl	<p>The diagnostics messages are not part of the process input data (object 5601_{hex}). Bytes 1 to 7 can therefore be used for the user data.</p> <hr/> <p>1 = The diagnostics messages are contained in byte 1 of the object 5601_{hex} (irrespective of "DisableDiagnostics"). Byte 0 contains the status and control byte. Bytes 2 to 7 are available for the user data. The structure of the object 5602_{hex} is also changed by this setting. At the location of the first data byte, byte 1 of the object 5602_{hex} contains a byte with two control bits. These can initiate a clearing of the receive and transmit buffer.</p>
BitRate Data rate	<p>0000 = reserved 0001 = 300 bps 0010 = 600 bps 0011 = 1200 bps 0100 = 2400 bps 0101 = 4800 bps 0110 = 9600 bps A 0111 = 14400 bps 1000 = 19200 bps 1001 = 28800 bps 1010 = 38400 bps 1011 = 57600 bps 1100 = 115200 bps 1101 = reserved 1110 = reserved 1111 = reserved</p>

FlowControl	00 = none A 01 = XON/XOFF 10 = RTS/CTS 11 = reserved
Data bits	0 = 7 A 1 = 8
Parity	00 = none 01 = odd (The parity bit is set so that the number of bits set to 1 (data and parity bit together) is odd.) A 10 = even (The parity bit is set so that the number of bits set to 1 (data and parity bit together) is even.)
Stop bits	0 = 1 1 = 2 A
XONChar	0 to 255 XON character (17 A) This character is used to start the data transfer of the data terminal device with software handshake activated.
XOFFChar	0 to 255 XOFF character (19 A) This character is used to stop the data transfer of the data terminal device with software handshake activated.

10.2.2 Object 5601_{hex} – RS232/RS4xx RxD

Process input data is data that is transmitted from the connected field device via the BL20-1RSxxx module to the communication partner (e.g. PLC). The data received from the device by the BL20-1RSxxx module is entered in a 128 byte receive buffer and then transferred in segments to the communication partner via the module bus and the gateway.

The transmission is realized in a 8-byte format which is structured as follows:

- 6 bytes or 7 bytes are used to contain the user data.
- 1 byte contains the diagnostics data depending on the parameter setting.
- 1 status byte is required to ensure trouble-free transmission of the data.

Table 119:
Object 5601_{hex}

Feature	Description
Name	RS232/RS4xx RxD
Object code	ARRAY
Data type	Unsigned64
Access	ro
Default value	No
PDO mapping	Yes

Structure of the data bytes with DisableReducedControl = 1 (in object 5600_{hex}):

	Bit 7	Bit 6	Bit 5	Bit 4	Bit 3	Bit 2	Bit 1	Bit 0
Byte 0 (Status)	STAT	TX_CNT_ACK		RX_CNT		RX_BYTE_CNT		
Byte 1 (Diag.)	BufOfI	Frame Err	HndShErr	Hw_Failure	PrmErr	X	X	X
Byte 2	data byte 0							
...	...							
Byte 7	data byte 5							

Structure of the data bytes with DisableReducedControl = 0 (in object 5600_{hex}):

	Bit 7	Bit 6	Bit 5	Bit 4	Bit 3	Bit 2	Bit 1	Bit 0
Byte 0 (Status)	STAT	TX_CNT_ACK		RX_CNT		RX_BYTE_CNT		
Byte 1	data byte 0							
...	...							
Byte 7	data byte 6							

Table 120:
Meaning of the
data bits

Designation	Value	Description
STAT	0-1	1 The communication with the data terminal equipment (DTE) is error free 0 The communication with the data terminal equipment (DTE) is disturbed. A diagnosis message is generated if the parameter „Diagnostics“ is set to "0" = release. The diagnostic data show the cause of the communication disturbance. The user has to set back this bit in the process output data by using STATRES (Object 5602 _{hex}).
TX_CNT_ACK	0-3	The value TX_CNT_ACK is a copy of the value TX_CNT. The value TX_CNT was transferred together with the last data segment of the process output data. The value TX_CNT_ACK is a confirmation of successful acceptance of the data segment using TX_CNT.
RX_CNT	0-3	This value is transferred together with every data segment. The RX_CNT values are sequential: 00->01->10->11->00... (decimal: 0->1->2->3->0...) Errors in this sequence show the loss of data segments.
RX_BYTE_CNT	0-7	Number of the valid bytes in this data segment.

Table 120:
Meaning of the
data bits

Designation	Value	Description
BufOvfl	Bit 7	0 = ok 1 = buffer overflow Overflow of the receive-buffer (RX-buffer).
FrameErr	Bit 6	0 = ok 1 = frame error The module has to be parameterized for adaptation to the data structure of the data terminal equipment (DTE). A frame error occurs in case of inconsequent parameterization (number of data bits, stop bits, method of parity,...).
HndShErr	Bit 5	0 = ok 11 = Data flow control error The DTE connected to the module does not react to XOFF or RTS handshake. The internal receive-buffer may overflow (buffer-overflow = 1).
HwFailure	Bit 4	0 = ok 1 = Hardware failure The module has to be replaced (e.g. error in EEPROM or UART).
PrmErr	Bit 3	0 = ok 1 = Parameterization error The parameter settings can not be supported.

10.2.3 Object 5602_{hex} – RS232/RS4xx TxD

Process output data are data which are sent from the PLC via the gateway and the RSxxx-module to a connected field device.

The data received from the PLC are loaded into the 64-bit transmit-buffer in the RSxxx-module.

The transmission is realized in a 8-byte format which is structured as follows:

- 6 bytes or 7 bytes are used to contain the user data.
- If parameterized, 1 byte contains, signals to start the flushing of transmit- and receive buffer.
- 1 control byte is required to ensure trouble-free transmission of the data.

Table 121:
Object 5602_{hex}

Feature	Description
Name	RS232/RS4xx TxD
Object code	ARRAY
Data type	Unsigned64
Access	rw
Default value	No
PDO mapping	Yes

Structure of the data bytes with DisableReducedControl = 1 (in object 5600_{hex}):

	Bit 7	Bit 6	Bit 5	Bit 4	Bit 3	Bit 2	Bit 1	Bit 0
Byte 0 (Status)	STAT RES	RX_CNT_ACK		TX_CNT		TX_BYTE_CNT		
Byte 1 (Diag.)	reserved						RXBUF FLUSH	TXBUF FLUSH
Byte 2	data byte 0							
...	...							
Byte 7	data byte 5							

Structure of the data bytes with DisableReducedControl = 0 (in object 5600_{hex}):

	Bit 7	Bit 6	Bit 5	Bit 4	Bit 3	Bit 2	Bit 1	Bit 0
Byte 0 (Status)	STAT RES	RX_CNT_ACK		TX_CNT		TX_BYTE_CNT		
Byte 1	data byte 0							
...	...							
Byte 7	data byte 6							

Table 122:
Meaning of the
data bits

Designation	Value	Description
STATRES	0-1	The STATRES bit is used for resetting the STAT bit of the process input data (object 5601 _{hex}). The STAT bit is reset (from 0 to 1) with the transition from 1 to 0 (falling edge). If this bit is 0, all changes in the data fields TX_BYTE_CNT, TX_CNT and RX_CNT_ACK are ignored. The clearing of the receive and transmit buffer by RXBUF FLUSH/TXBUF FLUSH is possible. The value 1 or the transition from 0 to 1 disables the clearing of the receive and transmit buffer by the RXBUF FLUSH/TXBUF FLUSH.
RX_CNT_ACK	0-3	The value RX_CNT_ACK is a copy of the value RX_CNT. The value RX_CNT was transferred together with the last data segment of the process input data (Object 5601 _{hex}). The value RX_CNT_ACK is a confirmation of successful acceptance of the data segment using RX_CNT.
TX_CNT	0-3	The value TX_CNT is transferred together with every data segment of the process output data. The TX_CNT values are sequential: 00->01->10->11->00... (decimal: 0->1->2->3->0...) Errors in this sequence show the loss of data segments.
TX_BYTE_CNT	0-7	Number of the valid bytes in this data segment.
RXBUF FLUSH	0-1	The RXBUF FLUSH bit is used for clearing the receive buffer. If STATRES = 1: A request with RXBUF FLUSH = 1 will be ignored. If STATRES = 0: RXBUF FLUSH = 1 will clear the receive buffer.
TXBUF FLUSH	0-1	The TXBUF FLUSH bit is used for clearing the transmit buffer. If STATRES = 1: A request with TXBUF FLUSH = 1 will be ignored. If STATRES = 0: TXBUF FLUSH = 1 will clear the receive buffer.

11 Objects for Encoder modules (SSI, CNT)

11.1	Encoder module BLxx	4
11.2	General object overview for encoder modules	4
11.2.1	Object 5800 _{hex} – Encoder Basic Mode	6
	– BL20-1CNT-24VDC	7
	– BL67-1CNT/ENC	7
11.2.2	Object 5801 _{hex} – Encoder Config	7
	– BLxx-1SSI	8
	– BL20-1CNT-24VDC	9
	– BL20-E-2CNT-2PWM	10
	– BL67-1CNT/ENC	11
11.2.3	Object 5802 _{hex} – Encoder Status	11
	– BLxx-1SSI	12
	– BL20-1CNT-24VDC	12
	– BL20-E-2CNT-2PWM	12
	– BL67-1CNT/ENC	13
11.2.4	Object 5803 _{hex} – Encoder Flags	13
	– BLxx-1SSI	13
	– BL20-1CNT-24VDC	14
	– BL20-E-2CNT-2PWM	14
	– BL67-1CNT/ENC	14
11.2.5	Objekt 5804 _{hex} – Encoder Diag	15
	– BLxx-1SSI	15
	– BL20-1CNT-24VDC	15
	– BL20-E-2CNT-2PWM	15
	– BL67-1CNT/ENC	16
11.2.6	Object 5805 _{hex} – Encoder Native Status	16
	– BLxx-1SSI	17
	– BL20-E-2CNT-2PWM	17
	– BL67-1CNT/ENC	17
11.2.7	Object 5806 _{hex} – Optional Encoder Status	18
	– BLxx-1SSI	18
	– BL20-E-2CNT-2PWM	19
	– BL67-1CNT/ENC	19
11.2.8	Object 5808 _{hex} – Encoder Control	19
	– BLxx-1SSI	19
	– BL20-1CNT-24VDC	20
	– BL20-E-2CNT-2PWM	20
	– BL67-1CNT/ENC	20
11.2.9	Object 5810 _{hex} – Encoder Load Prepare Value	21
	– BL20-1CNT-24VDC	21
	– BL20-E-2CNT-2PWM	21
	– BL67-1CNT/ENC	21
11.2.10	Object 5811 _{hex} – Encoder Pulse Width	22
	– BL20-1CNT-24VDC	22
	– BL20-E-2CNT-2PWM	22
11.2.11	Object 5820 _{hex} – Measuring Integration Time	22
	– BL20-1CNT-24VDC	23
	– BL20-E-2CNT-2PWM	23
11.2.12	Object 5821 _{hex} – Measuring Low Limit	23
	– BL20-1CNT-24VDC	23
11.2.13	Object 5822 _{hex} – Measuring High Limit	25
	– BL20-1CNT-24VDC	25

Objects for Encoder modules (SSI, CNT)

11.2.14	Object 5823 _{hex} – Measuring Units Per Revolution	25
	– BL20-1CNT-24VDC	26
11.2.15	Object 5824 _{hex} – Measuring Divisor	26
	– BL20-E-2CNT-2PWM	26
	– BL67-1CNT/ENC	26
11.2.16	Object 5825 _{hex} – Measuring Factor	27
	– BL20-E-2CNT-2PWM	27
	– BL67-1CNT/ENC	27
11.2.17	Object 5827 _{hex} – Measuring Timeout	27
	– BL20-E-2CNT-2PWM	28
	– BL67-1CNT/ENC	28
11.2.18	Object 5830 _{hex} – Measuring Value	28
	– BL20-E-2CNT-2PWM	28
	– BL67-1CNT/ENC	28
11.2.19	Object 5831 _{hex} – Encoder Latch Value	29
	– BL20-E-2CNT-2PWM	29
11.2.20	Object 5840 _{hex} – Diag Mapping	29
	– BLxx-1SSI	29
11.2.21	Object 5901 _{hex} – PWM Config	31
	– BL20-E-2CNT-2PWM	31
11.2.22	Object 5902 _{hex} – PWM Status	33
	– BL20-E-2CNT-2PWM	33
11.2.23	Object 5903 _{hex} – PWM Flags	34
11.2.24	Object 5904 _{hex} – PWM Diag	35
11.2.25	Object 5908 _{hex} – PWM Control	36
11.2.26	Object 5910 _{hex} – PWM Load Prepare Value	37
11.2.27	Object 5913 _{hex} – PWM Duty Cycle	38
11.2.28	Object 5920 _{hex} – PWM Period Duration	38
11.2.29	Object 5931 _{hex} – PWM Latch Value	39
11.2.30	Object 6800 _{hex} – Operating Parameters	39
11.2.31	Objekt 6810 _{hex} – Preset Values for Multi-Sensor Devices	40
	– BLxx-1SSI	40
	– BL20-1CNT-24VDC	40
	– BL20-E-2CNT-2PWM	40
	– BL67-1CNT/ENC	40
11.2.32	Object 6820 _{hex} – Position Value	41
	– BLxx-1SSI	41
11.2.33	Object 6B00 _{hex} – CAM State Register	41
	– BLxx-1SSI	42
	– BL20-1CNT-24VDC	42
	– BL20-E-2CNT-2PWM	42
11.2.34	Object 6B01 _{hex} – CAM1 Enable Register	43
11.2.35	Object 6B02 _{hex} – CAM Polarity Register	44
11.2.36	Object 6B10 _{hex} – CAM1 Low Limit	45
	– BLxx-1SSI	45
	– BL20-1CNT-24VDC	45
	– BL20-E-2CNT-2PWM	46
11.2.37	Object 6B20 _{hex} – CAM1 High Limit	46
	– BLxx-1SSI	46
	– BL20-1CNT-24VDC	46
	– BL20-E-2CNT-2PWM	47
11.2.38	Object 6B30 _{hex} – CAM1 Hysteresis	47
	– BL20-1CNT-24VDC	47
	– BL20-E-2CNT-2PWM	47
11.2.39	Object 6C00 _{hex} – Area State Register	48

– BL20-1CNT-24VDC	48
11.2.40 Object 6C01 _{hex} – Work Area Low Limit	49
– BL20-1CNT-24VDC	50
– BL20-E-2CNT-2PWM	50
11.2.41 Object 6C02 _{hex} – Work Area High Limit	50
– BL20-1CNT-24VDC	50
– BL20-E-2CNT-2PWM	50
11.2.42 Object 6D00 _{hex} – Operating Status, Object 6D01 _{hex} – SingleTurn Resolution (rotary), Measuring step (linear), Object 6D02 _{hex} – Number of Distinguishable Revolutions	51
11.2.43 Object 6FFF _{hex} – Device Type	51
11.3 Process output/ control interface of the Encoder modules	51
11.3.1 Meaning of the process output bits of BLxx-1SSI	51
11.3.2 Meaning of the process output bits of BL20-1CNT-24VDC	52
11.3.3 Meaning of the process output bits of BL20-E-2CNT-2PWM	55
11.3.4 Meaning of the process output bits of BL67-1CNT/ENC	57
11.4 Meaning of the process input bits of the Encoder modules	58
11.4.1 Meaning of the process input bits of BLxx-1SSI	58
11.4.2 Meaning of the process input bits of BL20-1CNT-24VDC	60
11.4.3 Meaning of the process input bits of BL20-E-2CNT-2PWM	62
11.4.4 Meaning of the process input bits of BL67-1CNT/ENC	65
11.5 Parameter interface of the Encoder modules	66
11.5.1 Meaning of the parameter bits of BLxx-1SSI	66
11.5.2 Meaning of the parameter bits of BL20-1CNT-24VDC	68
11.5.3 Meaning of the parameter bits of BL20-E-2CNT-2PWM	70
11.5.4 Meaning of the parameter bits of BL67-1CNT/ENC	73
11.6 Diagnostic interface of the Encoder modules	75
11.6.1 Meaning of the diagnostic bits of BLxx-1SSI	75
11.6.2 Meaning of the diagnostic bits of BL20-1CNT-24VDC	76
11.6.3 Meaning of the diagnostic bits of BL20-E-2CNT-2PWM	77
11.6.4 Meaning of the diagnostic bits of BL67-1CNT/ENC	78

11.1 Encoder module BLxx

The objects are used in the following modules:

*Table 123:
BLxx-Encoder
modules*

Product family	Module
BL20	BL20-1CNT-24VDC
	BL20-1SSI
	BL20-E-2CNT-2PWM
BL67	BL67-1SSI
	BL67-1CNT/ENC
BLC	miscellaneous

11.2 General object overview for encoder modules

*Table 124:
General object
overview for
encoder
modules*

Object	Name	Page
5800 _{hex}	Encoder Basic Mode	page 11-6
5801 _{hex}	Encoder Config	page 11-7
5802 _{hex}	Encoder Status	page 11-11
5803 _{hex}	Encoder Flags	page 11-13
5804 _{hex}	Encoder Diag	page 11-15
5805 _{hex}	SSI Native Status	page 11-16
5806 _{hex}	SSI Optional Encoder status	page 11-18
5808 _{hex}	Encoder Control	page 11-19
5810 _{hex}	Encoder Load Prepare	page 11-19
5811 _{hex}	Encoder Pulse Width	page 11-22
5820 _{hex}	Measuring Integration Time	page 11-22
5821 _{hex}	Measuring Low Limit	page 11-23
5822 _{hex}	Measuring High Limit	page 11-25
5823 _{hex}	Measuring Units Per Revolution	page 11-25
5824 _{hex}	Measuring Divisor	page 11-26
5825 _{hex}	Measuring Factor	page 11-27
5827 _{hex}	Measuring Timeout	page 11-27
5830 _{hex}	Measuring Value	page 11-28

5831 _{hex}	Encoder Latch Value	page 11-29
5840 _{hex}	Diag Mapping	page 11-29
5901 _{hex}	PWM Config	page 11-31
5902 _{hex}	PWM Status	page 11-33
5903 _{hex}	PWM Flags	page 11-34
5904 _{hex}	PWM Diag	page 11-35
5908 _{hex}	PWM Control	page 11-36
5910 _{hex}	PWM Load Prepare	page 11-38
5913 _{hex}	PWM Duty Cycle	page 11-39
5920 _{hex}	PWM Period Duration	page 11-39
5931 _{hex}	PWM Latch Value	page 11-40
6800 _{hex}	Operating Parameters	page 11-40
6810 _{hex}	Preset Value for Multi-Sensor Devices	page 11-41
6820 _{hex}	Position Value	page 11-42
6B00 _{hex}	CAN State Register	page 11-42
6B00 _{hex}	CAM Enable Register	page 11-44
6B00 _{hex}	CAM Polarity Register	page 11-45
6B10 _{hex}	CAM Low Limit	page 11-46
6B20 _{hex}	CAM High Limit	page 11-47
6B30 _{hex}	CAM1 Hysteresis	page 11-48
6C00 _{hex}	Area State Register	page 11-49
6C01 _{hex}	Work Area Low Limit	page 11-50
6C02 _{hex}	Work Area High Limit	page 11-51
6D00 _{hex}	Operating Status	page 11-52
6D01 _{hex}	SingleTurn Resolution (rotary), Measuring step (linear)	page 11-52
6D02 _{hex}	Number of Distinguishable Revolutions	page 11-52
6FFF _{hex}	Device Type	page 11-52

11.2.1 Object 5800_{hex} – Encoder Basic Mode

The object 5800_{hex} affects parts of the module parameters:

Write accesses initiate a parameter update via the internal module bus. The parameter is stored as a non-volatile parameter in the gateway and is restored with every node reset.

This object is used in the following modules. In all other encoder modules, this objects can only be found for compatibility reasons.

- BL20-1CNT-24VDC
- BL67-1CNT/ENC

Table 125:
Object 5800_{hex}

Feature	Description
Name	Encoder Basic Mode
Object code	ARRAY
PDO mapping	No
Sub-index	00 _{hex}
Data type	Unsigned8
Access	ro
Default value, BLxx	No
Sub-index	01 _{hex} - 47 _{hex}
Data type	Unsigned32
Access	rw
Default value, BLxx	No

BL20-1CNT-24VDC

The object 5800_{hex} affects the operation mode parameters of the BL20 counter module. It serves amongst others for setting the count operation or the measurement operation mode.

Structure of the data bytes for the count operation:

	Bit 7	Bit 6	Bit 5	Bit 4	Bit 3	Bit 2	Bit 1	Bit 0
Byte 0	reserved		Counter mode					
Byte 1	reserved	Main count direction		Synchroni- zation	Function DI		Digital input DI	Gate func- tion
Byte 2	reserved							
Byte 3	reserved							

X = reserved



Note

Please find a detailed description of the parameters in the table [Meaning of the parameter bits of BL20-1CNT-24VDC \(page 11-69\)](#).

Structure of the data bits in the measurement mode:

	Bit 7	Bit 6	Bit 5	Bit 4	Bit 3	Bit 2	Bit 1	Bit 0
Byte 0	reserved		Measurement mode					
Byte 1	reserved				Function DI		Digital input DI	reserved
Byte 2	reserved							
Byte 3	reserved							



Note

Please find a detailed description of the parameters in the table [Meaning of the parameter bits of BL20-1CNT-24VDC \(page 11-69\)](#).

BL67-1CNT/ENC

For this module, this object describes **parameter byte 14**.

Byte 14 of the modules' parameter data serves for defining the number of the register from the register interface (REG_PARA; REG_COUNTER_VALUE, REG_LOWER_LIMIT etc. see [D300572](#)) whose content has to be mapped into the process input data of the module.

The default value for the module BL67-1CNT/ENC is 32 (register-no. 32 „REG_COUNTER_VALUE“).

11.2.2 Object 5801_{hex} – Encoder Config

The object takes effect on parts of the respective module parameters and serves for configuration setting. Write accesses initiate a parameter update via the internal module bus. The parameter is stored as a non-volatile parameter in the gateway and is restored with every node reset.

This object is used in the following modules. In all other encoder modules, this objects can only be found for compatibility reasons.

- BLxx-1SSI
- BL20-1CNT-24VDC

- BL20-E-2CNT-2PWM
- BL67-1CNT/ENC

Table 126:
Object 5801_{hex}

Feature	Description
Name	Encoder Config
Object code	ARRAY
Data type	Unsigned32
Access	rw
Default value	No
PDO mapping	No

BLxx-1SSI

The Object Encoder Config takes effect on parameter bytes 0 ... 3 of the BL20-SSI module.

Structure of the data bytes 0 to 3 for the SSI-module:

	Bit 7	Bit 6	Bit 5	Bit 4	Bit 3	Bit 2	Bit 1	Bit 0
Byte 0 (Status)	reserved		DIS_ERR_SSI	reserved				
Byte 1	INVALID_BITS_MSB			INVALID_BITS_LSB				
Byte 2	reserved				SSI_BIT_RATE			
Byte 3	SSI_CODE_G/D	reserved	SSI_FRAME_LENGTH					



Note

Please find a detailed description of the parameters in the table [Meaning of the parameter bits of BLxx-1SSI \(page 11-67\)](#).

BL20-1CNT-24VDC

The Object Encoder Config takes effect on parameter bytes 12 ... 15 of the counter module.

Count operation:

	Bit 7	Bit 6	Bit 5	Bit 4	Bit 3	Bit 2	Bit 1	Bit 0
Byte 0	Function Do2			Function DO1			diagnostic DO1	substitute value DO1
Byte 1	direction input (B)	sensor (A)		sensor/ input filter (DI)	sensor/ input filter (BI)	sensor/ input filter (A)	signal evaluation (A B)	
Byte 2	reserved		behavior CPU/ master stop		reserved		Common diagnostics	
Byte 3	reserved							



Note

Please find a detailed description of the parameters in the table [Meaning of the parameter bits of BL20-1CNT-24VDC \(page 11-69\)](#).

Structure of the data bytes for the measurement operation:

	Bit 7	Bit 6	Bit 5	Bit 4	Bit 3	Bit 2	Bit 1	Bit 0
Byte 0				Function DO1			diagnostic DO1	substitute value DO1
Byte 1	direction input (B)	sensor (A)		sensor/ input filter (DI)	sensor/ input filter (BI)	sensor/ input filter (A)	signal evaluation (A B)	
Byte 2	reserved		behavior CPU/ master stop		reserved		Common diagnostics	
Byte 3	reserved							



Note

Please find a detailed description of the parameters in the table [Meaning of the parameter bits of BL20-1CNT-24VDC \(page 11-69\)](#).

BL20-E-2CNT-2PWM

Object Encoder Config takes effect on parameter bytes 0...2 and 10 (channel 1), or respectively 3...5 and 12 (channel 2) of the BL20-E-2CNT-2PWM.

Byte	Bit 7	Bit 6	Bit 5	Bit 4	Bit 3	Bit 2	Bit 1	Bit 0
0	input A1	input B1	input Z1	res.	diag- nostic CNT1	measure- ment mode CNT1	main count direction CNT1	
1	filter Z1		filter A1, B1		res.	pull up Z1	res.	threshold input A,B,Z CNT1
2	mode Z1				mode CNT1			
3	input A2	input B2	input Z2	res.	diagnostic	measure- ment mode CNT2	main count direction CNT2	
4	filter Z2		filter A2, B2		res.	pull up Z2	res.	threshold input A,B,Z CNT2
5	mode Z2				mode CNT2			
...	Object 5901							
10	res.	ADR AUX REG1 RD DATA						
...	Object 5901							
12	res.	ADR AUX REG3 RD DATA						
...	Object 5901							



Note

Please find a detailed description of the parameters in the table [Meaning of the parameter bits of BL20-E-2CNT-2PWM](#) (page 11-71).

BL67-1CNT/ENC

The Object Encoder Config has effect on parameter bytes 0 ... 0.3 of the BL67-1CNT/ENC module.

Byte	Bit 7	Bit 6	Bit 5	Bit 4	Bit 3	Bit 2	Bit 1	Bit 0
0	input A	input B	reserved	count direction	Signal evaluation		input filter (A B)	
1	input Z	reserved	Sync. with Z	reserved	Encoder signal	Function DO3	Function DI3	PullUp Z
2	threshold input A, B and Z							
3	reserved		Measurement mode	Counter mode	Gate	Gate function		
...								

input = input

Sync. = synchronization



Note

Please find a detailed description of the parameters in table [Meaning of the parameter bits of BL67-1CNT/ENC \(page 11-74\)](#).

11.2.3 Object 5802_{hex} – Encoder Status

The object Encoder Status displays the status of the modules' count direction.

This object is used in the following modules. In all other encoder modules, this objects can only be found for compatibility reasons.

- BLxx-1SSI
- BL20-1CNT-24VDC
- BL20-E-2CNT-2PWM
- BL67-1CNT/ENC

Table 127:
Object 5802_{hex}

Feature	Description
Name	Encoder Status
Object code	ARRAY
Data type	Unsigned8
Access	ro
Default value	No
PDO mapping	Yes

BLxx-1SSI

Bit 7	Bit 6	Bit 5	Bit 4	Bit 3	Bit 2	Bit 1	Bit 0
STS_DNS	STS_UP	reserved					



Note

Please find a detailed description of the status bits in the process input in table [Meaning of the process input bits of BLxx-1SSI \(page 11-59\)](#).

BL20-1CNT-24VDC

Bit 7	Bit 6	Bit 5	Bit 4	Bit 3	Bit 2	Bit 1	Bit 0
STS_DN	STS_UP	reserved	STS_DO2	STS_DO1	reserved	STS_DI	STS_GATE



Note

Please find a detailed description of the status bits in the process input in table [Meaning of the process input bits of BL20-1CNT-24VDC \(page 11-61\)](#).

BL20-E-2CNT-2PWM

The object 5802_{hex} supplies the following status messages:

- count direction
- status of in- and outputs
- operation status of the counter

Structure of the data bytes

Sub-index	Bit 7 (msb)	Bit 6	Bit 5	Bit 4	Bit 3	Bit 2	Bit 1	Bit 0 (lsb)
0x00 ≤ n ≤ 0x47								
n = CNT1	STS_CNT1_DN	STS_CNT1_UP	STS_CNT1_SFKT_EN	STS_DBP1	D1	STS_CNT1_GENERAL_EN	Z1	STS_CNT1_RUN
n + 1 = CNT2	STS_CNT2_DN	STS_CNT2_UP	STS_CNT2_SFKT_EN	STS_DBP2	D2	STS_CNT2_GENERAL_EN	Z2	STS_CNT2_RUN



Note

Please find a detailed description of the status bits in the process input in table [Meaning of the process input bits of BL20-E-2CNT-2PWM \(page 11-63\)](#).

BL67-1CNT/ENC

Bits 6 and 7 of the object Encoder Status describe the up/down direction of the current values.

Bit 7	Bit 6	Bit 5	Bit 4	Bit 3	Bit 2	Bit 1	Bit 0
STS_DNS	STS_UP	reserved					



Note

Please find a detailed description of the status bits in the process input in table [Meaning of the process input bits of BL67-1CNT/ENC \(page 11-66\)](#).

11.2.4 Object 5803_{hex} – Encoder Flags

The object contains volatile status messages as well as module flags.

This object is used in the following modules. In all other encoder modules, this objects can only be found for compatibility reasons.

- BLxx-1SSI
- BL20-1CNT-24VDC
- BL20-E-2CNT-2PWM
- BL67-1CNT/ENC

Table 128:
Object 5803_{hex}

Feature	Description
Name	Encoder Flags
Object code	ARRAY
Data type	Unsigned8
Access	rw
Default value	No
PDO mapping	Yes

BLxx-1SSI

The bits STS_OFLW and STS_UFLW are volatile status bits for the SSI module.

Writing the object with any value will reset the markers FLAG_CMP1 and FLAG_CMP2.

Exception:

if the relevant condition for setting a marker is still fulfilled, this marker will continue to remain set.

Structure of the data byte

Bit 7	Bit 6	Bit 5	Bit 4	Bit 3	Bit 2	Bit 1	Bit 0
reserved	STS_UFLW	STS_OFLW	FLAG_CMP2	FLAG_CMP1	reserved		



Note

Please find a detailed description of the status bits in the process input in table [Meaning of the process input bits of BLxx-1SSI \(page 11-59\)](#).

BL20-1CNT-24VDC

The object reads byte 6 of the check-back interface of the counter module.

This byte sends the stored status of some module flags.

The flags are reset by writing this object with any value.

Exception:

if the relevant condition for setting a marker is still fulfilled, this marker will continue to remain set.

Bit 7	Bit 6	Bit 5	Bit 4	Bit 3	Bit 2	Bit 1	Bit 0
STS_ND	STS_UFLW	STS_OFLW	STS_CMP2	STS_CMP1	reserved		STS_SYN



Note

Please find a detailed description of the status bits in the process input in table [Meaning of the process input bits of BL20-1CNT-24VDC \(page 11-61\)](#).

BL20-E-2CNT-2PWM

Sub-index $0 \times 00 \leq n \leq 0 \times 47$	Bit 7 (msb)	Bit 6	Bit 5	Bit 4	Bit 3	Bit 2	Bit 1	Bit 0 (lsb)
n = CNT1	MSG_CNT1_ND	MSG_CNT1_UFLW	MSG_CNT1_OFLW	MSG_CNT1_CMP1	MSG_CNT1_CMP0	MSG_CNT1_SW_LR	MSG_CNT1_SFKT	MSG_CNT1_FQE
n + 1 = CNT2	MSG_CNT2_ND	MSG_CNT2_UFLW	MSG_CNT2_OFLW	MSG_CNT2_CMP1	MSG_CNT2_CMP0	MSG_CNT2_SW_LR	MSG_CNT2_SFKT	MSG_CNT2_FQE



Note

Please find a detailed description of the status bits in the process input in table [Meaning of the process input bits of BL20-E-2CNT-2PWM \(page 11-63\)](#).

BL67-1CNT/ENC

The flags are reset by writing this object with any value.

Exception:

if the relevant condition for setting a marker is still fulfilled, this marker will continue to remain set.

Bit 7	Bit 6	Bit 5	Bit 4	Bit 3	Bit 2	Bit 1	Bit 0
STS_ZC	STS_UFLW	STS_OFLW	reserved				



Note

Please find a detailed description of the status bits in the process input in table [Meaning of the process input bits of BL67-1CNT/ENC \(page 11-66\)](#).

11.2.5 Objekt 5804_{hex} – Encoder Diag

This object reads the diagnostic byte of the encoder module.

This object is used in the following modules. In all other encoder modules, this objects can only be found for compatibility reasons.

- BLxx-1SSI
- BL20-1CNT-24VDC
- BL20-E-2CNT-2PWM
- BL67-1CNT/ENC

Table 129:
Object 5804_{hex}

Feature	Description
Name	Encoder Diag
Object code	ARRAY
Data type	Unsigned8
Access	ro
Default value	No
PDO mapping	No

BLxx-1SSI

Bit 7	Bit 6	Bit 5	Bit 4	Bit 3	Bit 2	Bit 1	Bit 0
reserved			ERR_ PARA	STS_ UFLW	STS_ OFLW	ERR_ SSI	SSI_ DIAG



Note

Please find a detailed description of the status bits in the process input in table [Meaning of the diagnostic bits of BLxx-1SSI \(page 11-76\)](#).

BL20-1CNT-24VDC

Bit 7	Bit 6	Bit 5	Bit 4	Bit 3	Bit 2	Bit 1	Bit 0
MEAS_ MODE	OPER_ MODE	ERR_ PARA				ERR_ 24Vdc	ERR_ DO



Note

Please find a detailed description of the status bits in the process input in table [Meaning of the diagnostic bits of BL20-1CNT-24VDC \(page 11-77\)](#).

BL20-E-2CNT-2PWM

Sub-index $0 \times 00 \leq n \leq 0 \times 47$	Bit 7 (msb)	Bit 6	Bit 5	Bit 4	Bit 3	Bit 2	Bit 1	Bit 0 (lsb)
n = CNT1	HW_ERR	CNT1_ PAR_ERR	CNT1_ERR_ UFLW	CNT1_ERR_ OFLW	reserved			
n + 1 = CNT2	HW_ERR	CNT2_ PAR_ERR	CNT2_ERR_ UFLW	CNT2_ERR_ OFLW	reserved			



Note

Please find a detailed description of the status bits in the process input in table [Meaning of the diagnostic bits of BL20-E-2CNT-2PWM \(page 11-78\)](#).

BL67-1CNT/ENC

Bit 7	Bit 6	Bit 5	Bit 4	Bit 3	Bit 2	Bit 1	Bit 0
ERR_ PARA	reserved	DIA_DO3	DIA_DO2	DIA_DO1	DIA_DO0	STS_ OFLW	STS_ UFLW



Note

Please find a detailed description of the status bits in the process input in table [Meaning of the diagnostic bits of BL67-1CNT/ENC \(page 11-79\)](#).

11.2.6 Object 5805_{hex} – Encoder Native Status

The object Encoder Native Status reads bytes 0 to 1 the the module's process input data.

This object is used in the following modules. In all other encoder modules, this objects can only be found for compatibility reasons.

- BLxx-1SSI
- BL20-E-2CNT-2PWM
- BL67-1CNT/ENC

Table 130:
Object 5805_{hex}

Feature	Description
Name	Encoder Native Status
Object code	ARRAY
Data type	Unsigned16
Access	rw
Default value	No
PDO mapping	Yes

BLxx-1SSI

Writing the object with any value will reset the non-volatile flags FLAG_CMP1 and FLAG_CMP2.

Exception:

if the relevant condition for setting a marker is still fulfilled, this marker will continue to remain set.

	Bit 7	Bit 6	Bit 5	Bit 4	Bit 3	Bit 2	Bit 1	Bit 0
Byte 0	STS_STOP	reserved		ERR_PARA	STS_UFLW	STS_OFLW	ERR_SSI	SSI_DIAG
Byte 1	STS_UP	STS_DN	REL_CMP2	FLAG_CMP2	STS_CMP2	REL_CMP1	FLAG_CMP1	STS_CMP1



Note

Please find a detailed description of the status bits in the process input in table [Meaning of the process input bits of BLxx-1SSI \(page 11-59\)](#).

BL20-E-2CNT-2PWM

The object reads the process input bytes 0 to 1 (channel 1) and 2 to 3 (channel 2) of the module.

Sub-index	Byte	Bit 7	Bit 6	Bit 5	Bit 4	Bit 3	Bit 2	Bit 1	Bit 0
$0 \times 00 \leq n \leq 0 \times 47$									
n = CNT1	0	A1	B1	Z1	STS_CNT1_DIR	STS_CNT1_LOGMSG	STS_CNT1_SFKT_EN	STS_CNT1_RUN	STS_CNT1_GENERAL_EN
	1	MSG_CNT1_SW_LR	MSG_CNT1_SFKT	MSG_CNT1_FQE	MSG_CNT1_ND	MSG_CNT1_OFLW	MSG_CNT1_UFLW	MSG_CNT1_CMP1	MSG_CNT1_CMP0
n + 1 = CNT2	2	A2	B2	Z2	STS_CNT2_DIR	STS_CNT2_LOGMSG	STS_CNT2_SFKT_EN	STS_CNT2_RUN	STS_CNT2_GENERAL_EN
	3	MSG_CNT2_SW_LR	MSG_CNT2_SFKT	MSG_CNT2_FQE	MSG_CNT2_ND	MSG_CNT2_OFLW	MSG_CNT2_UFLW	MSG_CNT2_CMP1	MSG_CNT2_CMP0



Note

Please find a detailed description of the status bits in the process input in table [Meaning of the process input bits of BL20-E-2CNT-2PWM \(page 11-63\)](#).

BL67-1CNT/ENC

The object reads the module's process input bytes 1 and 2.

Writing the object with any value will reset the non-volatile flags STS_ZC, STS_OFLW and STS_UFLW.

Byte	Bit 7	Bit 6	Bit 5	Bit 4	Bit 3	Bit 2	Bit 1	Bit 0	
1	ERR_PARA	SYNC_AKN	reserved						count direction
2	REG_WR_ACCEPT	REG_WR_AKN	reserved			STS_ZC	STS_OFLW	STS_UFLW	



Note

Please find a detailed description of the status bits in the process input in table [Meaning of the process input bits of BL67-1CNT/ENC](#) (page 11-66).

11.2.7 Object 5806_{hex} – Optional Encoder Status

The object Optional Encoder Status reads different bytes of the module's process input data.

This object is used in the following modules. In all other encoder modules, this objects can only be found for compatibility reasons.

- BLxx-1SSI
- BL20-E-2CNT-2PWM
- BL67-1CNT/ENC

Table 131:
Object 5806_{hex}

Feature	Description
Name	Optional Encoder Status
Object code	ARRAY
Data type	Unsigned8
Access	ro
Default value	No
PDO mapping	Yes

BLxx-1SSI

The object Optional Encoder Status reads byte 2 of the process input data of the BLxx-1SS module. Bits 6 and 7 are masked out.

Structure of the data byte

Bit 7	Bit 6	Bit 5	Bit 4	Bit 3	Bit 2	Bit 1	Bit 0
masked (0)	masked (0)	reserved		SSI_ STS3	SSI_ STS2	SSI_ STS1	SSI_ STS0



Note

Please find a detailed description of the status bits in the process input in table [Meaning of the process input bits of BLxx-1SSI](#) (page 11-59).

BL20-E-2CNT-2PWM

The object reads process input byte 6 of the 2CNT-2PWM module. Bits 5 to 7 are masked out.

Sub-index	Byte	Bit 7	Bit 6	Bit 5	Bit 4	Bit 3	Bit 2	Bit 1	Bit 0 (lsb)
$0 \times 00 \leq n \leq 0 \times 47$									
n = CNT1	0	reserved						STS_DBP1	D1
n + 1 = CNT2	0	reserved						STS_DBP2	D2



Note

Please find a detailed description of the status bits in the process input in table [Meaning of the process input bits of BL20-E-2CNT-2PWM \(page 11-63\)](#).

BL67-1CNT/ENC

The object reads process input byte 0 of the BL67-1CNT/ENC module.

Bit 7	Bit 6	Bit 5	Bit 4	Bit 3	Bit 2	Bit 1	Bit 0
reserved	A	B	Z	DI3	DI2	DI1	DI0



Note

Please find a detailed description of the status bits in the process input in table [Meaning of the process input bits of BL67-1CNT/ENC \(page 11-66\)](#).

11.2.8 Object 5808_{hex} – Encoder Control

Object 5808_{hex} writes and reads the different bytes of the modules' control interface and therefore serves for influencing the module during operation.

This object is used in the following modules. In all other encoder modules, this objects can only be found for compatibility reasons.

- BLxx-1SSI
- BL20-1CNT-24VDC
- BL20-E-2CNT-2PWM
- BL67-1CNT/ENC

Table 132:
Object 5808_{hex}

Feature	Description
Name	Encoder Control
Object code	ARRAY
Data type	Unsigned8
Access	rw
Default value	No
PDO mapping	Yes

BLxx-1SSI

The object writes or reads byte 0 of the control interface of the SSI-module.

At the moment, only bit 7 (STOP) is used.



Note

Please find a detailed description of the control bits in the process output in table [Meaning of the process output bits of BLxx-1SSI \(page 11-52\)](#).

BL20-1CNT-24VDC

The object Encoder Control writes or reads byte 4 of the module's control interface.

Count operation

Bit 7	Bit 6	Bit 5	Bit 4	Bit 3	Bit 2	Bit 1	Bit 0
reserved	CTRL_DO2	SET_DO2	CTRL_DO1	SET_DO1	reserved	CTRL_SYNC	SW_GATE

Measurement mode

Bit 7	Bit 6	Bit 5	Bit 4	Bit 3	Bit 2	Bit 1	Bit 0
reserved			CTRL_DO1	SET_DO1	reserved		SW_GATE



Note

Please find a detailed description of the control bits in the process output in table [Meaning of the process output bits of BL20-1CNT-24VDC \(page 11-53\)](#).

BL20-E-2CNT-2PWM

The object Encoder Control writes or reads byte 0 (channel 1), or respectively byte 1 (channel 2) of the module's process output data.

	Bit 7	Bit 6	Bit 5	Bit 4	Bit 3	Bit 2	Bit 1	Bit 0
n = CNT1	reserved	CNT1_SINGLE	CNT1_SW_LR	CNT1_SFKT_DISABLE	reserved	CNT1_LOGMSG	CNT1_ENABLE	CNT1_GENERAL_DISABLE
n + 1 = CNT2	reserved	CNT2_SINGLE	CNT2_SW_LR	CNT2_SFKT_DISABLE	reserved	CNT2_LOGMSG	CNT2_ENABLE	CNT2_GENERAL_DISABLE



Note

Please find a detailed description of the control bits in the process output in table [Meaning of the process output bits of BL20-E-2CNT-2PWM \(page 11-56\)](#).

BL67-1CNT/ENC

The object reads process input byte 0 of the BL67-1CNT/ENC module.

Bit 7	Bit 6	Bit 5	Bit 4	Bit 3	Bit 2	Bit 1	Bit 0
DO3	DO2	DO1	DO0	reserved	RES_STS	SYNC_REQ	GATE



Note

Please find a detailed description of the control bits in the process output in table [Meaning of the process output bits of BL67-1CNT/ENC](#) (page 11-58).

11.2.9 Object 5810_{hex} – Encoder Load Prepare Value

The object Setting the counter's count value to this value is event-driven. This object is used in the following modules. In all other encoder modules, this objects can only be found for compatibility reasons.

- BL20-1CNT-24VDC
- BL20-E-2CNT-2PWM
- BL67-1CNT/ENC

Table 133:
Object 5810_{hex}

Feature	Description
Name	Encoder Control
Object code	ARRAY
Data type	Unsigned8
Access	rw
Default value	No
PDO mapping	Yes

BL20-1CNT-24VDC

The object takes effect on the function „Load in preparation LOAD_PREPARE" in the module's control interface.

BL20-E-2CNT-2PWM

The object writes or reads register 23_{hex} (channel 1), or respectively register 43_{hex} (channel 2) of the module's register interface.

BL67-1CNT/ENC

The object writes or reads register 2c_{hex} (44) of the module's register interface.

11.2.10 Object 5811_{hex} – Encoder Pulse Width

The object serves for setting the pulse duration.

This object is used in the following modules. In all other encoder modules, this objects can only be found for compatibility reasons.

- BL20-1CNT-24VDC
- BL20-E-2CNT-2PWM

Table 134:
Object 5811_{hex}

Feature	Description
Name	Encoder Pulse Width
Object code	ARRAY
Data type	Unsigned16
Access	rw
Default value	No
PDO mapping	No

BL20-1CNT-24VDC

The object takes effect on the module'S parameter byte 11 and serves for setting the pulse duration at DO1 and DO2 in the count operation.

BL20-E-2CNT-2PWM

The object writes or reads register 30_{hex} (channel 1), or respectively register 50_{hex} (channel 2) of the module's register interface.

The time is set in 1ms/ bit.

Value range: 0 ms to 65535 ms (1min 5s).

11.2.11 Object 5820_{hex} – Measuring Integration Time

The object serves for setting the integration time.

This object is used in the following modules. In all other encoder modules, this objects can only be found for compatibility reasons.

- BL20-1CNT-24VDC
- BL20-E-2CNT-2PWM

Table 135:
Object 5820_{hex}

Feature	Description
---------	-------------

Name	Measuring Integration Time
Object code	ARRAY
Data type	Unsigned 32
Access	rw
Default value	-
PDO mapping	No

BL20-1CNT-24VDC

The object takes effect on parameter byte 8 and 9 and serves for setting the integration time in measurement mode.

Valid values are 1 to 1000.



Note

The object is only valid, if the counter module works in measurement mode.

BL20-E-2CNT-2PWM

The object writes or reads register 29_{hex} (channel 1), or respectively register 49_{hex} (channel 2) of the module's register interface.

For the frequency measurement and the rotation speed measurement, the integration time is entered in 10 ms/ bit.

11.2.12 Object 5821_{hex} – Measuring Low Limit

This object is used to set the module's lower limit in measurement mode.

This object is used in the following modules. In all other encoder modules, this objects can only be found for compatibility reasons.

- BL20-1CNT-24VDC

Table 136:
Object 5821_{hex}

Feature	Description
Name	Measuring Low Limit
Object code	ARRAY
Data type	Unsigned 32
Access	rw
Default value	-
PDO mapping	No

BL20-1CNT-24VDC

The object takes effect on parameter byte 2 and 4 and serves for setting the lower limit in measurement mode.

Objects for Encoder modules (SSI, CNT)

Permissible value range:
0 to 16777214



Note

The object is only valid, if the counter module works in measurement mode.

11.2.13 Object 5822_{hex} – Measuring High Limit

This object is used to set the module's upper limit in measurement mode.

This object is used in the following modules. In all other encoder modules, this objects can only be found for compatibility reasons.

- BL20-1CNT-24VDC

Table 137:
Object 5822_{hex}

Feature	Description
Name	Measuring High Limit
Object code	ARRAY
Data type	Unsigned 32
Access	rw
Default value	-
PDO mapping	No

BL20-1CNT-24VDC

The object takes effect on parameter byte 5 and 7 and serves for setting the upper limit in measurement mode.

Permissible value range: 1 to 16777215



Note

The object is only valid, if the counter module works in measurement mode.

11.2.14 Object 5823_{hex} – Measuring Units Per Revolution

Object 5823_{hex} is used to set the sensor pulses per revolution.

This object is used in the following modules. In all other encoder modules, this objects can only be found for compatibility reasons.

- BL20-1CNT-24VDC

Table 138:
Object 5823_{hex}

Feature	Description
Name	Measuring Units Per Revolution
Object code	ARRAY
Data type	Unsigned 16
Access	rw
Default value	-
PDO mapping	No

BL20-1CNT-24VDC

The object is used to set the sensor pulses per revolution for the counter module.

Value range: 1 to 65535.

11.2.15 Object 5824_{hex} – Measuring Divisor

The object serves for scaling the measured value.

This object is used in the following modules. In all other encoder modules, this objects can only be found for compatibility reasons.

- BL20-E-2CNT-2PWM
- BL67-1CNT/ENC

Table 139:
Object 5824_{hex}

Feature	Description
Name	Measuring Divisor
Object code	ARRAY
Data type	Unsigned32
Access	rw
Default value	-
PDO mapping	No

BL20-E-2CNT-2PWM

The object writes or reads register 2B_{hex} (channel 1), or respectively Register 4B_{hex} (channel 2) of the module's register interface.

BL67-1CNT/ENC

The object writes or reads register 38_{hex} (56) of the module's register interface.

11.2.16 Object 5825_{hex} – Measuring Factor

The object serves for scaling the measured value.

This object is used in the following modules. In all other encoder modules, this objects can only be found for compatibility reasons.

- BL20-E-2CNT-2PWM
- BL67-1CNT/ENC

Table 140:
Object 5825_{hex}

Feature	Description
Name	Measuring Factor
Object code	ARRAY
Data type	Unsigned 32
Access	rw
Default value	-
PDO mapping	No

BL20-E-2CNT-2PWM

The object writes or reads register 2A_{hex} (channel 1), or respectively Register 4A_{hex} (channel 2) of the module's register interface.

BL67-1CNT/ENC

The object writes or reads register 34_{hex} (52) of the module's register interface.

11.2.17 Object 5827_{hex} – Measuring Timeout

The object defines the time out after which, in period duration measurement, a message is generated. The current period duration measurement is monitored.

This object is used in the following modules. In all other encoder modules, this objects can only be found for compatibility reasons.

- BL20-E-2CNT-2PWM
- BL67-1CNT/ENC

Table 141:
Object 5827_{hex}

Feature	Description
Name	Measuring Timeout
Object code	ARRAY
Data type	Unsigned 32
Access	rw
Default value	-
PDO mapping	No

BL20-E-2CNT-2PWM

The object writes or reads register 2D_{hex} (channel 1), or respectively Register 4D_{hex} (channel 2) of the module's register interface.

BL67-1CNT/ENC

The object writes or reads register 3C_{hex} (60) of the module's register interface.

11.2.18 Object 5830_{hex} – Measuring Value

The object reads the measured value.

This object is used in the following modules. In all other encoder modules, this objects can only be found for compatibility reasons.

- BL20-E-2CNT-2PWM
- BL67-1CNT/ENC

Table 142:
Object 5830_{hex}

Feature	Description
Name	Measuring Value
Object code	ARRAY
Data type	Unsigned 32
Access	rw
Default value	-
PDO mapping	No

BL20-E-2CNT-2PWM

The object writes or reads register 21_{hex} (channel 1), or respectively register 41_{hex} (channel 2) of the module's register interface.

BL67-1CNT/ENC

The object writes or reads register 30_{hex} (48) of the module's register interface.

11.2.19 Object 5831_{hex} – Encoder Latch Value

The object reads the value of the counters' latch-register.

This object is used in the following modules. In all other encoder modules, this objects can only be found for compatibility reasons.

- BL20-E-2CNT-2PWM

Table 143:
Object 5831_{hex}

Feature	Description
Name	Encoder Latch Value
Object code	ARRAY
Data type	Unsigned 32
Access	rw
Default value	-
PDO mapping	No

BL20-E-2CNT-2PWM

The object writes or reads register 28_{hex} (channel 1), or respectively register 48_{hex} (channel 2) of the module's register interface.

11.2.20 Object 5840_{hex} – Diag Mapping

This object is used in the following modules. In all other encoder modules, this objects can only be found for compatibility reasons.

- BLxx-1SSI

BLxx-1SSI

The object writes or reads register 51 (REG_SSI_MASK) of the module.

REG_SSI_MASK contains the SSI encoder diagnostics transferred. Some SSI encoders not only transfer the position value in the data frame that they transfer to the module but also supply additional status messages.

It is advisable to include these status messages in the application in order to analyze the measured value.

Writing the REG_SSI_MASK register allows up to four individual bits to be taken from the SSI encoder data frame and transferred to the SSI_STSx bits of the process input data.

Objects for Encoder modules (SSI, CNT)

Table 144:
Object 5840_{hex}

Feature	Description
Name	SSI Diag Mapping
Object code	ARRAY
Data type	Unsigned32
Access	rw
Default value	No
PDO mapping	No

Masking through REG_SSI_MASK:

process input data	REG_SSI_MASK								
	Byte	Bit 7	Bit 6	B 5	B 4	B 3	B 2	B 1	B 0
SSI_STS0	0	EN_D0_RMS0	EN_D0_DS	X	SSI_FRAME_BIT_SELO				
SSI_STS1	1	EN_D1_RMS1	EN_D1_DS	X	SSI_FRAME_BIT_SEL1				
SSI_STS2	2	EN_D2_RMS2	EN_D2_DS	X	SSI_FRAME_BIT_SEL2				
SSI_STS3	3	EN_D3_RMS3	EN_D3_DS	X	SSI_FRAME_BIT_SEL3				

Table 145:
Bit-meaning

ADefault-setting

Designation	Value	Description
EN_Dx_RMSx	0 A	The mapping of the SSI status messages into the process input data is not activated.
	1	The mapping of the SSI status messages into the process input data is not activated.
EN_Dx_DS	0 A	The evaluation of the SSI status messages for bit 0 of the diagnostics is not activated.
	1	The evaluation of the SSI status messages for bit 0 of the diagnostics is activated.
SSI_FRAME_BIT_SEL	0 A	Definition of the selected bits in the frame of the SSI encoder Default: 0

The following applies to bit 0 (SSI group diagnostics) of the diagnostics interface and SSI_DIAG of the process input data:

$(SSI_STS0 \& EN_D0_DS) \parallel (SSI_STS1 \& EN_D1_DS) \parallel$
 $(SSI_STS2 \& EN_D2_DS) \parallel (SSI_STS3 \& EN_D3_DS)$

11.2.21 Object 5901_{hex} – PWM Config

This object is used in the following modules.

- BL20-E-2CNT-2PWM

Table 146:
Object 5901_{hex}

Feature	Sub-index	Description
Name		PWM Config
Object code		ARRAY
Data type	0x00	Unsigned 8
	0x01 to 0x47	Unsigned 32
Access	0x00	ro
	0x01 to 0x47	rw
Default value	0x00	-
PDO mapping		No

BL20-E-2CNT-2PWM

The object affects the configuration parameters of the PWMx:

Sub-index	Byte	Bit 7	Bit 6	Bit 5	Bit 4	Bit 3	Bit 2	Bit 1	Bit 0 (lsb)
0x00 ≤ n ≤ 0x47									
n = PWM1	0	diagnostic PWM1	X	mode D1 (0x3F)					
	1	Bit 15	Bit 14	Bit 13	Bit 12	Bit 11	Bit 10	Bit 9	Bit 8
		DBP1 STS MODE 0x00		substitute value P1 0x00	substitute value D1 0x00	mode PWM1 0x00			
	2	Bit 23	Bit 22	Bit 21	Bit 20	Bit 19	Bit 18	Bit 17	Bit 16
		X							
	3	Bit 31 (msb)	Bit 30	Bit 29	Bit 28	Bit 27	Bit 26	Bit 25	Bit 24
X		ADR AUX REG1 WR DATA (0x60)							

Sub-index $0 \times 00 \leq n \leq 0 \times 47$	Byte	Bit 7	Bit 6	Bit 5	Bit 4	Bit 3	Bit 2	Bit 1	Bit 0 (lsb)
n + 1 = PWM2	0	diagnostic PWM2	X	mode D2 (0x3F)					
	1	Bit 15	Bit 14	Bit 13	Bit 12	Bit 11	Bit 10	Bit 9	Bit 8
		DBP2 STS MODE 0x00		substitute value P2 (0x00)	substitute value D2 0x00	mode PWM2 0x00			
	2	Bit 23	Bit 22	Bit 21	Bit 20	Bit 19	Bit 18	Bit 17	Bit 16
		X							
	3	Bit 31 (msb)	Bit 30	Bit 29	Bit 28	Bit 27	Bit 26	Bit 25	Bit 24
X		ADR AUX REG3 WR DATA (0x70)							

() = default parameterization



Note

Please find a detailed description of the parameters in the table [Meaning of the parameter bits of BL20-E-2CNT-2PWM](#) (page 11-71).

11.2.22 Object 5902_{hex} – PWM Status

This object is used in the following modules.

- BL20-E-2CNT-2PWM

BL20-E-2CNT-2PWM

The object supplies the following status messages:

- output status
- operation status of the PWM

Table 147:
Object 5902_{hex}

Feature	Sub-index	Description
Name		PWM Status
Object code		ARRAY
PDO mapping		Yes
Data type	0x00	Unsigned 8
	0x01 to 0x47	Unsigned 8
Access	0x00	ro
	0x01 to 0x47	ro
Default value	0x00	-
	0x01 to 0x47	-

Structure of the data byte

Sub-index	Byte	Bit 7	Bit 6	Bit 5	Bit 4	Bit 3	Bit 2	Bit 1	Bit 0
0x00 ≤ n ≤ 0x47									
n = PWM1	0	X	X	STS_DBP1	D1	STS_PWM1_LOGMSG	STS_PWM1_SFKT_EN	STS_PWM1_RUN	STS_PWM1_GENERAL_EN
n + 1 = PWM2	0	X	X	STS_DBP2	D2	STS_PWM2_LOGMSG	STS_PWM2_SFKT_EN	STS_PWM2_RUN	STS_PWM2_GENERAL_EN



Note

Please find a detailed description of the status bits in the process input in table [Meaning of the process input bits of BL20-E-2CNT-2PWM \(page 11-63\)](#).

11.2.23 Object 5903_{hex} – PWM Flags

This object is used in the following modules.

- BL20-E-2CNT-2PWM

BL20-E-2CNT-2PWM

The object supplies the following status messages:

- reaching of limit values
- execution of a SW latch retrigger
- an event defined as special function (SFKT) has occurred
- a time out in the count pulse measurement occurred

Table 148:
Object 5903_{hex}

Feature	Sub-index	Description
Name		PWM Flags
Object code		ARRAY
PDO mapping		Yes
Data type	0x00	Unsigned 8
	0x01 to 0x47	Unsigned 8
Access SDO	0x00	ro
	0x01 to 0x47	rw
Access PDO	0x01 to 0x47	r
Default value	0x00	-
	0x01 to 0x47	-



Note

By means of this access, the messages are reset automatically after reading.

Structure of the data byte

Sub-index	Byte	Bit 7	Bit 6	Bit 5	Bit 4	Bit 3	Bit 2	Bit 1	Bit 0
0x00 ≤ n ≤ 0x47									
n = PWM1	0	X	X	X	X	MSG_ PWM1_ DO_ERR	MSG_ PWM1_ SFKT	MSG_ PWM1_ NDDC	MSG_ PWM1_ SW_LR
n + 1 = PWM2	0	X	X	X	X	MSG_ PWM2_ DO_ERR	MSG_ PWM2_ SFKT	MSG_ PWM2_ NDDC	MSG_ PWM2_ SW_LR



Note

Please find a detailed description of the status bits in the process input in table [Meaning of the process input bits of BL20-E-2CNT-2PWM](#) (page 11-63).

11.2.24 Object 5904_{hex} – PWM Diag

This object is used in the following modules.

- BL20-E-2CNT-2PWM

BL20-E-2CNT-2PWM

The object reads the module's diagnostic byte.

Table 149:
Object 5904_{hex}

Feature	Sub-index	Description
Name		PWM Diag
Object code		ARRAY
PDO mapping		–
Data type	0x00	Unsigned 8
	0x01 to 0x47	Unsigned 8
Access	0x00	ro
	0x01 to 0x47	ro
Default value	0x00	-
	0x01 to 0x47	-



Note

By means of this access, the messages are reset automatically after reading.

Structure of the data byte

Sub-index	Byte	Bit 7	Bit 6	Bit 5	Bit 4	Bit 3	Bit 2	Bit 1	Bit 0
0x00 ≤ n ≤ 0x47									
n = PWM1	0	HW_ERR	PWM1_ PAR_ERR	X	X	X	X	P1_DIAG	D1_DIAG
n + 1 = PWM2	0	HW_ERR	PWM2_ PAR_ERR	X	X	X	X	P2_DIAG	D2_DIAG



Note

Please find a detailed description of the status bits in the process input in table [Meaning of the diagnostic bits of BL20-E-2CNT-2PWM](#) (page 11-78).

11.2.25 Object 5908_{hex} – PWM Control

This object is used in the following modules.

- BL20-E-2CNT-2PWM

BL20-E-2CNT-2PWM

The object provides the following control functions:

- general enable of the function
- start/ stop of the signal output
- Freezing the module's error messages to enable reading them without data loss
- enabling or disabling of the special function
- executing a software latch retrigger
- Setting the single/ continuous signal output

Table 150:
Object 5908_{hex}

Feature	Sub-index	Description
Name		PWM Control
Object code		ARRAY
PDO mapping		Yes
Data type	0x00	Unsigned 8
	0x01 to 0x47	Unsigned 16
Access SDO	0x00	ro
	0x01 to 0x47	rw
Access PDO	0x01 to 0x47	r
Default value	0x00	-
	0x01 to 0x47	-



Note

By means of this access, the messages are reset automatically after reading.

Structure of the data byte

Sub-index $0 \times 00 \leq n \leq 0 \times 47$	Byte	Bit 7	Bit 6	Bit 5	Bit 4	Bit 3	Bit 2	Bit 1	Bit 0 (lsb)
n = PWM1	0	X	PWM1_SINGLE	PWM1_SW_LR	PWM1_SFKT_DISABLE	X	PWM1_LOGMSG	PWM1_ENABLE	PWM1_GENERAL_DISABLE
	1	Bit 15 (msb)	Bit 14	Bit 13	Bit 12	Bit 11	Bit 10	Bit 9	Bit 8
		X	X	X	X	X	X	SET_P1	SET_D1
n + 1 = PWM2	0	X	PWM2_SINGLE	PWM2_SW_LR	PWM2_SFKT_DISABLE	X	PWM2_LOGMSG	PWM2_ENABLE	PWM2_GENERAL_DISABLE
	1	Bit 15 (msb)	Bit 14	Bit 13	Bit 12	Bit 11	Bit 10	Bit 9	Bit 8
		X	X	X	X	X	X	SET_P2	SET_D2



Note

Please find a detailed description of the status bits in the process input in table [Meaning of the process output bits of BL20-E-2CNT-2PWM \(page 11-56\)](#).

11.2.26 Object 5910_{hex} – PWM Load Prepare Value

This object is used in the following modules.

- BL20-E-2CNT-2PWM

BL20-E-2CNT-2PWM

The object contains the load value (load value register, PWM1 no. 0x64, PWM2 no. 0x74) for the "prepared loading" of the counters. Setting the count value of the signals to be given out to this value is event-driven.

Table 151:
Object 5910_{hex}

Feature	Sub-index	Description
Name		PWM Load Prepare Value
Object code		ARRAY
PDO mapping		-
Data type	0x00	Unsigned 8
	0x01 to 0x47	Integer 32
Access	0x00	ro
	0x01 to 0x47	rw
Default value	0x00	-
	0x01 to 0x47	-

11.2.27 Object 5913_{hex} – PWM Duty Cycle

This object is used in the following modules.

- BL20-E-2CNT-2PWM

BL20-E-2CNT-2PWM

The object serves for setting the Duty Cycle of the PWM pulse (Register for Duty Cycle): PWM1, no. 0x64/ PWM2, no. 0x71.)

Table 152:
Object 5913_{hex}

Feature	Sub-index	Description
Name		PWM Duty Cycle
Object code		ARRAY
PDO mapping		-
Data type	0x00	Unsigned 8
	0x01 to 0x47	Integer 32
Access	0x00	ro
	0x01 to 0x47	rw
Default value	0x00	-
	0x01 to 0x47	-

11.2.28 Object 5920_{hex} – PWM Period Duration

The object contains the value for the period duration of the PWM (register for period duration: PWM1, no. 0x60/ PWM2, no. 0x70.)

Table 153:
Object 5920_{hex}

Feature	Sub-index	Description
Name		PWM Period Duration
Object code		ARRAY
PDO mapping		Yes
Data type	0x00	Unsigned 8
	0x01 to 0x47	Integer 32
Access SDO	0x00	ro
	0x01 to 0x47	rw
Access PDO	0x01 to 0x47	rw
Default value	0x00	-
	0x01 to 0x47	-

11.2.29 Object 5931_{hex} – PWM Latch Value

The object reads the value of the PWMs' latch-register (PWM1, no. 0x66/ PWM2 no. 0x76).

Table 154:
Object 5931_{hex}

Feature	Sub-index	Description
Name		PWM Latch Value
Object code		ARRAY
PDO mapping		-
Data type	0x00	Unsigned 8
	0x01 to 0x47	Unsigned 32
Access	0x00	ro
	0x01 to 0x47	ro
Default value	0x00	-
	0x01 to 0x47	-

11.2.30 Object 6800_{hex} – Operating Parameters



Note

Object 6800_{hex} (corresponds to object 6000_{hex} in accordance with CiA DS406) has no meaning with BL20xx and only exists because it is a "mandatory" object in accordance with DS406.

Table 155:
Object 6800_{hex}

Feature	Description
Name	Operating Parameters
Object code	VAR
Data type	Unsigned16
Access	rw
Default value	00h
PDO mapping	No

11.2.31 Objekt 6810_{hex} – Preset Values for Multi-Sensor Devices

The corresponds to object 6010_{hex} in accordance with CiA DS406 and is used for zero point adaption of the system.

This object is used in the following modules. In all other encoder modules, this objects can only be found for compatibility reasons.

- BLxx-1SSI
- BL20-1CNT-24VDC
- BL20-E-2CNT-2PWM
- BL67-1CNT/ENC

Table 156:
Object 6810_{hex}

Feature	Description
Name	Position Value for Multi-Sensor Devices
Object code	ARRAY
Data type	Integer32
Access	rw
Default value	No
PDO mapping	Yes

BLxx-1SSI

The content of this object is added to the SSI encoder value. The calculated value is stored to object 6820_{hex}.

BL20-1CNT-24VDC

The object writes the load value for the counter value.

BL20-E-2CNT-2PWM

The object writes the load value for the counter value.

BL67-1CNT/ENC

The object writes the load value for the counter value.

11.2.32 Object 6820_{hex} – Position Value

This object is used in the following modules. In all other encoder modules, this objects can only be found for compatibility reasons.

- BLxx-1SSI

Table 157:
Object 6820_{hex}

Feature	Description
Name	Position Value for Multi-Sensor Devices
Object code	ARRAY
Data type	Integer32
Access	ro
Default value	No
PDO mapping	Yes

BLxx-1SSI

Object 6820_{hex} (corresponds to object 6020_{hex} as per CiA DS406) contains the SSI encoder value of the BLxx-1SSI module. The content of the object contains a value that is added to correct the measured value for a zero point adjustment.

11.2.33 Object 6B00_{hex} – CAM State Register

The object CAM State register indicates in accordance with DS406 whether the actual counter status is within the range defined by CAM1 Low limit and CAM1 High limit (object 6B10_{hex} and 6B20_{hex}).

This object is used in the following modules. In all other encoder modules, this objects can only be found for compatibility reasons.

- BLxx-1SSI
- BL20-1CNT-24VDC
- BL20-E-2CNT-2PWM

Table 158:
Object 6B00_{hex}

Feature	Description
Name	CAM State Register
Object code	ARRAY
Data type	Unsigned8
Access	ro
Default value	No
PDO mapping	Yes

Structure of the data byte:

	Bit 7	Bit 6	Bit 5	Bit 4	Bit 3	Bit 2	Bit 1	Bit 0
channel 1	X	X	X	X	X	X	X	STAT_ CAM1

X = reserved

Table 159:
Meaning of the
data bits

	Designation		Description
A Object 6B02 _{hex} can be used to invert the values.	STAT_CAM1 A	0	The counter value lies within the following range: compare value2 ≤ counter value □ compare value1 or the conditions for activating this status message has not been fulfilled.
		1	The counter value lies out of the following range: compare value2 ≤ counter value □ compare value1

BLxx-1SSI

For this module, the object behavior is as defined per DS406. Special configuration settings are not necessary.

BL20-1CNT-24VDC

The behavior of the BL20 counter module is only according to DS406, if the configuration and the operation mode is the following:

- Operation mode is set to „count“.
- The operation mode for DO1 is set to "On when cnt. value □ ref. value1"
- The operation mode for DO2 is set to "On when cnt. value □ ref. value2"
- The enable bits for DO1 and DO2 are set.

Please observe the following:

- Object 6B10_{hex} "CAM1 Low Limit" corresponds to reference value2 of the BL20-counter module.
- Object 6B20_{hex} "CAM1 High Limit" corresponds to reference value1 of the BL20-counter module.
- The both outputs DO1 and DO2 are assigned to the 2 reference values.
- Object 6B00_{hex} „CAM 1 State Register“ provides the result of the AND relation of the two outputs DO1 and DO2.

BL20-E-2CNT-2PWM

For this module, the object behavior is as defined per DS406. Special configuration settings are not necessary.

The following applies:

STS_DBPx = 1

at (REG_CNTx_CMP0) ≤ (REG_CNTx_CNT) < (REG_CNTx_CMP1)

Structure of the data byte

Sub-index $0 \times 00 \leq n \leq 0 \times 47$	Byte	Bit 7	Bit 6	Bit 5	Bit 4	Bit 3	Bit 2	Bit 1	Bit 0 (lsb)
n = CNT1	0	X	X	X	X	X	X	X	STAT_ CAM1(STS _DBP1)
n + 1 = CNT2	0	X	X	X	X	X	X	X	STAT_ CAM2(STS _DBP2)



Note

The function is only given, if DBPx STS MODE = 00 is parameterized, see [section „Meaning of the parameter bits of BL20-1CNT-24VDC“](#).

11.2.34 Object 6B01_{hex} – CAM1 Enable Register

The object activates or deactivates the status message concerning the comparison result (Object 6B00_{hex}).

This object is used in the following modules. In all other encoder modules, this objects can only be found for compatibility reasons.

- BLxx-1SSI
- BL20-1CNT-24VDC
- BL20-E-2CNT-2PWM

Table 160:
Object 6B01_{hex}

Feature	Description
Name	CAM Enable register
Object code	ARRAY
Data type	Unsigned8
Access	rw
Default value	No
PDO mapping	No

Structure of the data byte:

	Bit 7	Bit 6	Bit 5	Bit 4	Bit 3	Bit 2	Bit 1	Bit 0
channel 1	X	X	X	X	X	X	X	EN_CAM1
channel 2	X	X	X	X	X	X	X	EN_CAM2

X = reserved

Table 161:
Meaning of the
data bits

Designation		Description
EN_CAM1	0	Object 6B00 _{hex} is blocked.
	1	Object 6B00 _{hex} is released.

11.2.35 Object 6B02_{hex} – CAM Polarity Register

The object 6B02_{hex} can invert the status message for the comparison result (Object 6B00_{hex}).

This object is used in the following modules. In all other encoder modules, this objects can only be found for compatibility reasons.

- BLxx-1SSI
- BL20-1CNT-24VDC
- BL20-E-2CNT-2PWM

Table 162:
Object 6B02_{hex}

Feature	Description
Name	CAM Polarity Register
Object code	ARRAY
PDO mapping	No
Sub-index	00 _{hex}
Data type	Unsigned8
Access	ro
Default value	No
Sub-index	01 _{hex} - 47 _{hex}
Data type	Unsigned8
Access	rw
Default value	0 _{hex}

Structure of the data byte:

	Bit 7	Bit 6	Bit 5	Bit 4	Bit 3	Bit 2	Bit 1	Bit 0
channel 1	X	X	X	X	X	X	X	POL_ CAM1
channel 2	X	X	X	X	X	X	X	POL_ CAM2

X = reserved

Table 163:
Meaning of the
data bits

Designation		Description
POL_CAM1	0	The status message of object 6B00 _{hex} is not inverted.
	1	The status message of object 6B00 _{hex} is inverted.

11.2.36 Object 6B10_{hex} – CAM1 Low Limit

The object is the same as object 6310_{hex} in accordance with CiA DS406 which defines a lower switch limit for the count range.

This object is used in the following modules. In all other encoder modules, this objects can only be found for compatibility reasons.

- BLxx-1SSI
- BL20-1CNT-24VDC
- BL20-E-2CNT-2PWM

Table 164:
Object 6B10_{hex}

Feature	Description
Name	CAM1 Low Limit
Object code	ARRAY
PDO mapping	No
Sub-index	00 _{hex}
Data type	Unsigned8
Access	ro
Default value	No
Sub-index	01 _{hex} - 47 _{hex}
Data type	Unsigned32
Access	rw
Default value	No

BLxx-1SSI

Object CAM1 Low Limit corresponds to the reference value2 (CmpVal2) of the SSI module.

BL20-1CNT-24VDC

The object corresponds to the reference value2 of the counter module

The logical output DO2, whose behavior can be configured in manifold ways, is assigned to reference value 2 and thus to object CAM1 Low Limit.

If reference value2 serves as lower limit, depends on the configuration of DO2. In order to achieve a CAM-function as per DS406 a special configuration is necessary, see description of [Object 6B00hex – CAM State Register \(page 11-42\)](#).

BL20-E-2CNT-2PWM

The object corresponds to the reference value CMP0 of the counter module

The object writes or reads register 26_{hex} (channel 1), or respectively register 46_{hex} (channel 2) of the module's register interface.

11.2.37 Object 6B20_{hex} – CAM1 High Limit

The object is the same as object 6320_{hex} in accordance with CiA DS406 which defines an upper switch limit for the count range.

This object is used in the following modules. In all other encoder modules, this objects can only be found for compatibility reasons.

- BLxx-1SSI
- BL20-1CNT-24VDC
- BL20-E-2CNT-2PWM

Table 165:
Object 6B20_{hex}

Feature	Description
Name	CAM1 High Limit
Object code	ARRAY
PDO mapping	No
Sub-index	00 _{hex}
Data type	Unsigned8
Access	ro
Default value	No
Sub-index	01 _{hex} - 47 _{hex}
Data type	Integer32
Access	rw
Default value	0000 _{hex}

BLxx-1SSI

Object CAM1 High Limit corresponds to the reference value1 (CmpVal1) of the SSI module.

BL20-1CNT-24VDC

The object corresponds to the reference value1 of the counter module

The logical output DO1, whose behavior can be configured in manifold ways, is assigned to reference value1 and thus to object CAM1 High Limit.

If reference value1 serves as upper limit, depends on the configuration of DO1.

In order to achieve a CAM-function as per DS406 a special configuration is necessary, see description of [Object 6B00hex – CAM State Register \(page 11-42\)](#).

BL20-E-2CNT-2PWM

The object corresponds to the reference value CMP1 of the counter module

The object writes or reads register 27_{hex} (channel 1), or respectively register 47_{hex} (channel 2) of the module's register interface.

11.2.38 Object 6B30_{hex} – CAM1 Hysteresis

Per DS406, the object defines a hysteresis value which serves as offset for the switch points CAM1 Low Limit and CAM1 High Limit in case of switching-on and -off.

This object is used in the following modules. In all other encoder modules, this objects can only be found for compatibility reasons.

- BL20-1CNT-24VDC
- BL20-E-2CNT-2PWM

Table 166:
Object 6B31_{hex}

Feature	Description
Name	CAM1 Hysteresis
Object code	ARRAY
PDO mapping	No
Sub-index	00 _{hex}
Data type	Unsigned8
Access	ro
Default value	No
Sub-index	01 _{hex} - 47 _{hex}
Data type	Unsigned16
Access	rw
Default value	No

BL20-1CNT-24VDC

The object defines the hysteresis value for reference value2 (CAM1 Low Limit - Object 6B10_{hex}) and reference value1 (CAM1 High Limit Object 6B20_{hex}).



Note

The object 6B30_{hex} is only valid, if the counter module works in count mode.

BL20-E-2CNT-2PWM

The object defines the hysteresis value for compare values CMP0 and CMP1 which affects the digital output Dx and the STS_DBPx assigned to the counter.

The object writes or reads register 2F_{hex} (channel 1), or respectively Register 4F_{hex} (channel 2) of the module's register interface.

11.2.39 Object 6C00_{hex} – Area State Register

Object 6C00_{hex} (corresponds to Object 6400_{hex} acc. to CiA DS406) contains two status bits per channel which report an underflow at the lower count limit (Object 6C01_{hex} Work Area Low Limit) and an overflow at the upper count limit (Object 6C02_{hex} Work Area High Limit).

The status bits are non-volatile. All status messages are reset by writing Object 5803_{hex} with any value.

This object is used in the following modules. In all other encoder modules, this objects can only be found for compatibility reasons.

- BL20-1CNT-24VDC
- BL20-E-2CNT-2PWM

Table 167:
Object 6C00_{hex}

Feature	Description
Name	Area State Register
Object code	ARRAY
PDO mapping	No
Sub-index	00 _{hex}
Data type	Unsigned8
Access	ro
Default value	No
Sub-index	01 _{hex} - 47 _{hex}
Data type	Unsigned8
Access	ro
Default value	No

BL20-1CNT-24VDC

Structure of the data byte

Bit 7	Bit 6	Bit 5	Bit 4	Bit 3	Bit 2	Bit 1	Bit 0
X	X	X	X	X	STS_ UFLW	STS_ OFLW	X



Note

Please find a detailed description of the status bits in the process input in table [Meaning of the process input bits of BL20-1CNT-24VDC \(page 11-61\)](#).

BL20-E-2CNT-2PWM

Structure of the data byte

Sub-index $0 \times 00 \leq n \leq 0 \times 47$	Byte	Bit 7	Bit 6	Bit 5	Bit 4	Bit 3	Bit 2	Bit 1	Bit 0 (lsb)
n = CNT1	0	X	X	X	X	X	MSG_ CNT1_ UFLW	MSG_ CNT1_ OFLW	X
n + 1 = CNT2	0	X	X	X	X	X	MSG_ CNT2_ UFLW	MSG_ CNT2_ OFLW	X



Note

Please find a detailed description of the status bits in the process input in table [Meaning of the process input bits of BL20-E-2CNT-2PWM \(page 11-63\)](#).

11.2.40 Object 6C01_{hex} – Work Area Low Limit

Object 6C01_{hex} (corresponds to 6401_{hex} acc. to CiA DS406) defines the value for the lower count limit.

In case of an underflow, bit 2 in object 6C00_{hex} and bit 6 object 5803_{hex} in are set.

This object is used in the following modules. In all other encoder modules, this objects can only be found for compatibility reasons.

- BL20-1CNT-24VDC
- BL20-E-2CNT-2PWM

Table 168:
Object 6C01_{hex}

Feature	Description
Name	Work Area Low Limit
Object code	ARRAY
PDO mapping	No
Sub-index	00 _{hex}
Data type	Unsigned8
Access	ro
Default value	No
Sub-index	01 _{hex} - 47 _{hex}
Data type	Unsigned32
Access	rw
Default value	No

BL20-1CNT-24VDC



Note

The object 6B30_{hex} is only valid, if the counter module works in count mode.

BL20-E-2CNT-2PWM

The object writes or reads register 24_{hex} (channel 1), or respectively register 44_{hex} (channel 2) of the module's register interface.

11.2.41 Object 6C02_{hex} – Work Area High Limit

Object 6C02_{hex} (corresponds to 6402_{hex} acc. to CiA DS406) defines the value for the upper count limit. In case of an overflow, bit 1 in object 6C00_{hex} and bit 56 object 5803_{hex} in are set. In all other encoder modules, this objects can only be found for compatibility reasons.

- BL20-1CNT-24VDC
- BL20-E-2CNT-2PWM

Table 169:
Object 6C02_{hex}

Feature	Description
Name	Work Area High Limit
Object code	ARRAY
PDO mapping	No
Sub-index	00 _{hex}
Data type	Unsigned8
Access	ro
Default value	No
Sub-index	01 _{hex} - 47 _{hex}
Data type	Unsigned32
Access	rw
Default value	No

BL20-1CNT-24VDC



Note

The object 6B30_{hex} is only valid, if the counter module works in count mode.

BL20-E-2CNT-2PWM

The object writes or reads register 25_{hex} (channel 1), or respectively register 45_{hex} (channel 2) of the module's register interface.

11.2.42 Object 6D00_{hex} – Operating Status, Object 6D01_{hex} – SingleTurn Resolution (rotary), Measuring step (linear), Object 6D02_{hex} – Number of Distinguishable Revolutions



Note

The objects 6D00_{hex} to 6D02_{hex} (correspond to objects 6500_{hex} to 6502_{hex} acc. to CiA DS406) only exist because they are mandatory objects acc. to DS406 and do not have any importance for BLxx. The objects are always set to 0 in BLxx.

11.2.43 Object 6FFF_{hex} – Device Type

Object 6FFF_{hex} (corresponds to object 67FF_{hex} in accordance with CiA DS406) specifies the type of the second device profile supported.

The object contains the value 000A0191_{hex}.

The low word (0196_{hex} = 406_{dez}) specifies the device profile.

The high word (000A_{hex}) describes the encoder type in accordance with CiA DS-406: (10_{dec} = Multi Sensor Encoder Interface).

Table 170:
Object 6FFF_{hex}

Feature	Description
Name	Device Type
Object code	VAR
PDO Mapping	No
Data type	Unsigned32
Access	ro

11.3 Process output/ control interface of the Encoder modules

11.3.1 Meaning of the process output bits of BLxx-1SSI

Table 171:
Meaning of the process output bits of BLxx-1SSI, alphabetically sorted

Designation	Value	Description
CLR_CMPx	0	Default status, i.e. reset of FLAG_CMPx not active.
	1	Reset of FLAG_CMPx active.

Table 171:
Meaning of the
process output
bits of BLxx-
1SSI,
alphabetically
sorted

Designation	Value	Description
EN_CMPx	0	Default status, i.e. the data bits REL_CMPx, STS_CMPx and FLAG_CMPx always have the value 0, irrespective of the actual SSI encoder value.
	1	Default status, i.e. the data bits REL_CMPx, STS_CMPx and FLAG_CMPx always have a value based on the result of the comparison with the SSI encoder value.
REG_RD_ADR	0..63	Address of the register to be read. If the read operation is successful (REG_RD_ABORT = 0), the user data is located in REG_RD_DATA of the process input data (bytes 0 to 3).
REG_WR	0	Default status, i.e. there is no request to overwrite the content of the register with the address stated at REG_WR_ADR with REG_WR_DATA. Bit REG_WR_AKN (see section „Meaning of the process input bits of BLxx-1SSI“) is reset (0) if necessary.
	1	Request to overwrite the content of the register with address REG_WR_ADR with REG_WR_DATA.
REG_WR_ADR	0..63	Address of the register, which has to be written with REG_WR_DATA.
REG_WR_DATA	0... 232-1	Value which has to be written to the register with the address REG_WR_ADR.
STOP	0	Request to read the SSI encoder cyclically
	1	Request to interrupt communication with the encoder

11.3.2 Meaning of the process output bits of BL20-1CNT-24VDC

Table 172:
Meaning of the
process output
bits of BL20-
1CNT-24VDC,
alphabetically
sorted

Designation	Value	Description
CTRL_DOx	0	The output DOx is blocked.
	1	The output DOx is released.
CTRL_SYN	0 → 1	Release synchronization: A rising edge at the physical DI input enables the counter value to be set (synchronized) once/periodically to the load value.

Table 172:
Meaning of the
process output
bits of BL20-
1CNT-24VDC,
alphabetically
sorted

Designation	Value	Description
EXTF_ACK	1	Error acknowledgement The error bits must be acknowledged with the control bit EXTF_ACK after the cause of the fault has been rectified. This control bit must then be reset again. Any new error messages are not set while the EXTF_ACK control bit is set!
Hysteresis value	0 to 255	The reference value 1/2 can be assigned a hysteresis value in order to generate a response at DO1/DO2 with hysteresis. This will prevent the excessive on and off switching of DO1/DO2 if the count value fluctuates too quickly around the reference value.
Pulse duration	0 to 255	unit: ms If the DO1/DO2 outputs are set to indicate counter status =reference value1/2, a longer pulse is some-times required to indicate equal values.
LOAD_CMP_VALx	1	Parameterization: "reference value x" The value in bytes 0 to 3 is accepted as a reference value x.
LOAD_DO_PARAM	0 → 1	Parameter definition of the DO1 physical output and the virtual output DO2. DO1 and DO2 can indicate the status of data bit SET_DO1 and SET_DO2 or comparison results. The latest telegram (MODE_DO1 and MODE_DO2) indicates the function required for DO1 and DO2.
LOAD_INTTIME	0 → 1	Parameterization: "Integration time" Bytes 0 to 1 of this process output represent a factor for defining the Integration time for frequency measurement and for determining the rotational speed. The integration time can be adjusted between 10 ms and 10 s in 10 ms increments and is produced by multiplying the factor x 10 ms. With period duration measurement, this factor determines the number of periods measured in order to calculate a mean value. A factor 1 to 1000 (1 _{hex} to 3E8 _{hex}) is permissible.
LOAD_LOLIMIT	0 → 1	Parameter setting of the lower measuring limit The value in bytes 0 to 3 is accepted as lower measuring limit. LOAD_LOLIMIT: 0 to 199 999 999 x10 ⁻³ Hz 0 to 24 999 999 x 10 ⁻³ U/min 0 to 99 999 999 ms
LOAD_PREPARE	0 → 1	Parameterization: "Load counter in preparation" The value in bytes 0 to 3 is accepted as a load value.

Table 172:
Meaning of the
process output
bits of BL20-
1CNT-24VDC,
alphabetically
sorted

Designation	Value	Description
LOAD_UPLIMIT	0 → 1	Parameter setting of the upper measuring limit The value in bytes 0 to 3 is accepted as upper measuring limit. LOAD_UPLIMIT: 1 to 200 000 000 x 10 ⁻³ Hz 1 to 25 000 000 x 10 ⁻³ U/min 1 to 100 000 000 ms
LOAD_VAL	0 → 1	Parameterization: "Load counter directly" The value in bytes 0 to 3 is accepted as new counter value.
MODE_DOx		MODE_DOx is only valid, if LOAD_DO_PARAM: 0 → 1 The output DOx can show the status of the data bit SET_DOx or comparison results, if CTRL_DOx = 1. MODE_DOx defines which function DO2 is to accept: – 00 The output DOx shows the status of the control bit SET_DOx. This must be released with CTRL_DOx = 1. – 01 Output DOx indicates: Counter value ≥ reference value x – 10 Output DOx indicates: Counter value ≤ reference value x – 11 Output DOx indicates: Counter value = reference value x A pulse is generated for indicating equal values. The pulse duration is defined by byte 2 of this process output.
RES_STS	0 → 1	0 → 1 Initiate resetting of status bits. Status bits STS_ND, STS_UFLW, STS_OFLW, STS_CMP2, STS_CMP1, STS_SYN (process input) are reset. Bit RES_STS_A = 1 (process input) acknowledges that the reset command has been received. RES_STS can now be reset to 0.
SET_DOx		f CTRL_DOx = 1 and the physical output DOx is set to indicate the value SET_DOx, DOx can be set and reset directly with SET_DOx. DO1 can be set for this function via the process output (MODE_DOx = 00 and LOAD_DO_PARAM 0 → 1). The output DOx can also be set before commissioning via the separate parameter data. The default setting for DOx is to display the value of SET_DOx.
SW_GATE	0 → 1	Counting is started (release).
	1 → 0	Counting is stopped.

11.3.3 Meaning of the process output bits of BL20-E-2CNT-2PWM

Table 173:
Meaning of the
process output
bits of BL20-E-
2CNT-2PWM,
alphabetically
sorted

Bit	Value	Meaning
AUX_REGx_WR_DAT A, Byte 0 ... AUX_REG1_WR_DAT A, byte 3	0 ... 2 ³² -1	Value which is written to the register with the address defined in ADR AUX REGx WR DATA in the parameterization.
AUX_REG1_WR_EN ... AUX_REG3_WR_EN	0	Disabling the writing of register data with the register contents in AUX_REGx_WR_DATA. This option avoids an unintentional writing to the registers in the register interface during a module power-up.
	1	Writing of the Register interface with the register contents in AUX_REGx_WR_DATA is enabled.
CNTx_ENABLE	0	Not activated
	1	Enable counter CNTx (SW gate)
CNTx_GENERAL_DISABLE	0	Count function unit CNTx is generally enabled
	1	Counter function unit is generally disabled
CNTx_LOGMSG	0	The messages in the MSG-bits in the process input/ check-back interface are active.
	1	With a change from 0 → 1 the MSG data are held and actual incoming messages are stored to the register REG_CNTx_LOGMSG. Before switching to REG_CNTx_LOGMSG, this register is set to "0". With a change from 1 → 0, all data from REG_CNTx_LOGMSG are copied to the MSG-bits in the check-back interface.
CNT1_SFKT_DISABLE	0	The special function of input Zx is enabled depending on the parameterization in "mode Zx".
	1	The special function of input Zx is disabled.
CNTx_SINGLE	0	Single enabling of CNTx
	1	Continuous enabling of CNTx
CNTx_SW_LR	0	Not activated
	1	A (SW) latch retrigger has to be executed at counter CNTx with a change from 0 → 1.
PWMx_ENABLE	0	Not activated
	1	Enable output PWMx (The enable is done either per SW- or per HW gate.)

Table 173:
Meaning of the
process output
bits of BL20-E-
2CNT-2PWM,
alphabetically
sorted

Bit	Value	Meaning
PWMx_GENERAL_DISABLE	0	Not activated
	1	Output PWMx generally enabled
PWMx_LOGMSG	0	The messages in the MSG-bits in the process input/ check-back interface are active.
	1	With a change from 0 → 1 the MSG data are held and actual incoming messages are stored to the register REG_CNTx_LOGMSG. Before switching to REG_CNTx_LOGMSG, this register is set to "0". With a change from 1 → 0, all data from REG_CNTx_LOGMSG are copied to the MSG-bits in the check-back interface.
PWMx_SINGLE	0	Single enabling of PWMx
	1	Continuous enabling of PWM
PWMx_SFKT_DISABLE	0	Enable the special function of input Zx depending on the parameterization.
	1	Disable the special function of input Zx depending on the parameterization.
PWMx_SW_LR	0	Not activated
	1	A latch retrigger has to be executed at counter PWMx with a change from 0 → 1 .
REG_RD_ADR	0...127	Address of the register which has to be read. If RD_ABORT = 0, then the user data can be found in REG_RD_DATA in the process input/ check-back interface.
REG_WR	0	Initial state
	1	Triggering a write command. The register of which the address has been defined with REG_WR_ADR, will be written with data from REG_WR_DATA.
REG_WR_ADR	0...127	Address of the register, which has to be written with REG_WR_DATA (see below).
REG_WR_DATA, byte 0 ... REG_WR_DATA, byte 3	0 ... 2 ³² -1	Value which, during a write operation, has to be written to the register selected with REG_WR_ADR (see above).
SET_Dx	0	Clearing of bit Dx
	1	Setting the bit Dx

Table 173:
Meaning of the
process output
bits of BL20-E-
2CNT-2PWM,
alphabetically
sorted

Bit	Value	Meaning
SET_Px	0	Clearing of bit Px
	1	Setting the bit Px

11.3.4 Meaning of the process output bits of BL67-1CNT/ENC

Table 174:
Meaning of the
process output
bits of BL67-
1CNT/ENC,
alphabetically
sorted

Bit	Value	Meaning
DOx	0	Digital output DOx = 0
	1	Digital output DOx = 1
GATE	0	Counter inactive
	1	Counter active, depending on parameter Gate function
REG_RD_ADR	0 to 127	Address of the register which has to be read. If RD_ABORT = 0, the user data can be found in REG_RD_DATA in the status interface (bytes 4-7).
RES_STS		During the change from 0 to 1 the counter status bits (STS_UFLW and STS_OFLW) are reset.
REG_WR	0	Initial state
	1	Command: write register Request to overwrite the content of the register with address REG_WR_ADR with REG_WR_DATA.
REG_WR_ADR	0 to 127	Address of the register, which has to be written with REG_WR_DATA.
REG_WR_DATA	0 to $2^{32}-1$	Value which, during a write operation, has to be written to the register selected with REG_WR_ADR.
SYNC_REQ	1	Synchronization request The bit SYNC_AKN of the status interface is reset.

11.4 Meaning of the process input bits of the Encoder modules

11.4.1 Meaning of the process input bits of BLxx-1SSI

Table 175:
Meaning of the
process input
bits of BLxx-
1SSI,
alphabetically
sorted

Designation	Value	Description
ERR_PARA	0	The parameter set of the module has been accepted.
	1	Operation of the module is not possible with the present parameter set.
ERR_SSI	0	SSI encoder signal present.
	1	SSI encoder signal faulty. (e.g. due to a cable break).
FLAG_CMPx	0	Default status, i.e. the register contents have not yet matched (REG_SSI_POS) = (REG_CMPx) since the last reset.
	1	The contents of the registers match (REG_SSI_POS) = (REG_CMPx). This marker must be reset with CLR_CMPx = 1 in the process output data.
REG_RD_ABORT	0	The reading of the register defined in REG_RD_ADR has been accepted and executed. The content of the register can be found in the user data (REG_RD_DATA, byte 0-3).
	1	Reading of the register defined in REG_RD_ADR has not been accepted. The user data range (REG_RD_DATA Bytes 0-3) is zero.
REG_RD_DATA	0... 2 ³² -1	Content of the register to be read if REG_RD_ABORT=0. If REG_RD_ABORT=1, then REG_RD_DATA=0.
REG_RD_ADR	0...63	Address of the register to be read. If the read operation is successful (REG_RD_ABORT = 0), the user data is located in REG_RD_DATA of the process input data (bytes 0 to 3).
REG_WR_ACCEPT	0	Writing the user data from the process output to the register addressed with REG_WR_ADR in the process output could not be done.
	1	Writing the user data from the process output to the register addressed with REG_WR_ADR in the process output was successful.

Table 175:
Meaning of the
process input
bits of BLxx-
1SSI,
alphabetically
sorted

Designation	Value	Description
REG_WR_AKN	0	No modification of the data in the register bank by process output, i.e. REG_WR = 0. A write job would be accepted with the next telegram of process output data. (handshake for data transmission to the register.)
	1	A modification of the register contents by a process output was initiated, which means REG_WR = 1 → section „Meaning of the process output bits of BLxx-1SSI“ . A write job would not be accepted with the next telegram of process output data.
REL_CMPx	0	A comparison of the register contents has produced the following result: (REG_SSI_POS) < (REG_CMP1)
	1	A comparison of the register contents has produced the following result: (REG_SSI_POS) ≥ (REG_CMP1)
REL_CMPx	0	A comparison of the register contents has produced the following result: (REG_SSI_POS) < (REG_CMPx)
	1	A comparison of the register contents has produced the following result: (REG_SSI_POS) ≥ (REG_CMP2)
SSI_DIAG	0	No enabled status signal is active (SSI_STSx = 0).
	1	At least one enabled status signal is active (SSI_STSx = 1)
SSI_STSx	0	These four bits transfer the status bits of the SSI encoder with the status messages of the SSI module. With some SSI encoders, the status bits are transferred together with the position value.
	1	
STS_CMP1	0	A comparison of the register contents has produced the following result: (REG_SSI_POS) ≠ (REG_CMP1)
	1	A comparison of the register contents has produced the following result: (REG_SSI_POS) = (REG_CMP1)
STS_CMP2	0	A comparison of the register contents has produced the following result: (REG_SSI_POS) ≠ (REG_CMP1)
	1	A comparison of the register contents has produced the following result: (REG_SSI_POS) = (REG_CMP2)

Table 175:
Meaning of the
process input
bits of BLxx-
1SSI,
alphabetically
sorted

Designation	Value	Description
STS_DN (LED DN)	0	The SSI encoder values are incremented or the values are constant.
	1	The SSI encoder values are decremented.
STS_OFLW	0	A comparison of the register contents has produced the following result: $(REG_SSI_POS) \leq (REG_UPPER_LIMIT)$
	1	A comparison of the register contents has produced the following result: $(REG_SSI_POS) > (REG_UPPER_LIMIT)$
STS_UFLW	0	A comparison of the register contents has produced the following result: $(REG_SSI_POS) \geq (REG_LOWER_LIMIT)$
	1	A comparison of the register contents has produced the following result: $(REG_SSI_POS) < (REG_LOWER_LIMIT)$
STS_UP (LED UP)	0	The SSI encoder values are decremented or the values are constant.
	1	The SSI encoder values are incremented.
STS_STOP	0	The SSI encoder is read cyclically.
	1	Communication with the SSI encoder is stopped as STOP = 1 (process output) or ERR_PARA = 1.

11.4.2 Meaning of the process input bits of BL20-1CNT-24VDC

Table 176:
Meaning of the
process input
bits of BL20-
1CNT-24VDC,
alphabetically
sorted

Designation	Value	Description
ERR_24Vdc	1	Short-circuit sensor supply: This diagnostics information must be acknowledged with the EXT_F_ACK (process output) control bit.
ERR_DO	1	Short-/open circuit/excess temperature at the output DO1: This diagnostics information must be acknowledged with the EXT_F_ACK (process output) control bit.

Table 176:
Meaning of the
process input
bits of BL20-
1CNT-24VDC,
alphabetically
sorted

Designation	Value	Description
ERR_LOAD	1	Error with load function Control bits LOAD_DO_PARAM, LOAD_CMP_VAL2, LOAD_CMP_VAL1, LOAD_PREPARE and LOAD_VAL must not be set at the same time during the transfer. An incorrect value was transferred with the control bits. Example: The values for "load load value directly" or "load load value in preparation" have been chosen above the upper or below the lower count limit.
ERR_PARA	0	The parameter definition is correct as per specification.
	1	There is a parameter error. ERR_PARA is a group diagnostics bit. With the separate diagnostics message bits 3 to 6 describe the parameter errors in more detail.
RES_STS_A	0	The last process output telegram contained: RES_STS = 0.
	1	Resetting of status bits running. The last process output telegram contained: RES_STS = 1.
STS_CMP1	1	Status comparator 1 This status bit indicates a comparison result for comparator 1 if: the output DO1 is released with CTRL_DO1 = 1 <u>and</u> a comparison is run via MODE_DO1 = 01, 10 or 11. Otherwise STS_CMP1 simply indicates that the output is or was set. STS_CMP1 is also set if DO1 SET_DO1 = 1 when the output is not released. This bit must be reset by the RES_STS control bit.
STS_CMP2	1	Status comparator 2 This status bit indicates a comparison result for comparator 2 if: the output DO2 is released with CTRL_DO2 = 1 <u>and</u> a comparison is run via MODE_DO2 = 01, 10 or 11. Otherwise STS_CMP2 simply indicates that the output is or was set. STS_CMP2 is also set if DO1 SET_DO2 = 1 when the output is not released. This bit must be reset by the RES_STS control bit.
STS_DN	1	Status direction down.
STS_DI	1	The DI status bit indicates the status of digital input DI.
STS_DO1	1	The DO1 status bit indicates the status of digital output DO1.
STS_DO2	1	The DO2 status bit indicates the status of digital output DO2.
STS_GATE	1	Counting operation running.

Table 176:
Meaning of the
process input
bits of BL20-
1CNT-24VDC,
alphabetically
sorted

Designation	Value	Description
STS_LOAD	1	Status of load function is set, if the Load function is running.
STS_ND	1	Status zero crossing Set on crossing zero in counter range when counting without main direction. This bit must be reset by the RES_STS control bit.
STS_OFLW	1	Status upper count limit Set if the counter goes above the upper count limit. This bit must be reset by the RES_STS control bit.
STS_UFLW	1	Status lower count limit Set if the count value goes below the lower count limit. This bit must be reset by the RES_STS control bit.
STS_UP	1	Status direction up.
STS_SYN	1	Status synchronization After synchronization is successfully completed the STS_SYN status bit is set. This bit must be reset by the RES_STS control bit.

11.4.3 Meaning of the process input bits of BL20-E-2CNT-2PWM

Table 177:
Meaning of the
process input
bits of BL20-E-
2CNT-2PWM,
alphabetically
sorted

Bit	Value	Meaning
CNTx		
STS_CNTx_GENERAL_EN	1	Function enabled
STS_CNTx_RUN	1	CNTx Counter ready to count
STS_CNTx_SFKT_EN	1	Special function of Z disabled for CNTx
STS_CNTx_LOGMSG	0	Status of MSG bits actual
	1	Status of MSG bits are held
STS_CNTx_DIR	0	CNTx Counter counts down
	1	CNTx Counter counts up

Table 177:
Meaning of the
process input
bits of BL20-E-
2CNT-2PWM,
alphabetically
sorted

Bit	Value	Meaning
Ax, Bx, Zx	0	Digital input is ‚LOW‘
	1	Digital input is ‚HIGH‘
MSG_CNTx_CMP0	1	The counter CNTx reports that the compare value CMP0 was reached.
MSG_CNTx_CMP1	1	The counter CNTx reports that the compare value CMP1 was reached.
MSG_CNTx_UFLW	1	The counter CNTx reports the lower count limit was reached.
MSG_CNTx_OFLW	1	The counter CNTx reports the upper count limit was reached.
MSG_CNTx_ND	1	The counter CNTx reports a zero crossing.
MSG_CNTx_FQE	1	The counter CNTx reports an error in frequency/ period duration measurement. Error cause: Max. length of the no-pulse period reached. The value cannot be displayed correctly in the register for the "pulses per integration time" REG_CNTx_IPI due to a multiplier which has been set too high in register REG_CNTx_MUL.
MSG_CNTx_SFKT	1	The event according to there parameterized special function CNTx_SFKT_DISABLE did occur .
MSG_CNTx_SW_LR	1	The function Latch-Retrigger has been activated via bit CNTx_SW_LR = 1.
PWMx		
MSG_PWM1x_SW_LR	1	The function Latch-Retrigger has been activated via bit PWMx_SW_LR = 1.
MSG_PWMx_NDDC	1	The counter PWMx reports a zero crossing.
MSG_PWMx_SFKT	1	The event according to there parameterized special function PWMx_SFKT_DISABLE did occur .
MSG_PWMx_DO_ERR	1	One of the outputs Px (Px_DIAG) or Dx (Dx_DIAG) of the corresponding PWMx-channel sent an error.
STS_PWMx_GENERAL_EN	1	Function enabled, with a change from 0 \rightarrow 1 the channel is set to the initial state
STS_PWMx_RUN	1	PWMx-signal output active
STS_PWMx_SFKT_EN	1	Special function of Z enabled for PWMx
STS_PWMx_LOGMSG	0	Status of MSG bits actual
	1	Status of MSG bits are held

Table 177:
Meaning of the
process input
bits of BL20-E-
2CNT-2PWM,
alphabetically
sorted

Bit	Value	Meaning
Communication		
Dx	0	Digital output is ,LOW'
	1	Digital output is 'HIGH'
STS_DBPx	1	Status of the information defined through DBPx STS MODE.
STS_CONFIG_ERR	1	In REG_CONFIG_ERR an error is reported
REG_RD_ABORT	0	The reading of the register defined in REG_RD_ADR has been accepted and executed. The content of the register can be found in the user data (REG_RD_DATA).
	1	Reading of the register defined in REG_RD_ADR has not been accepted. The register content (REG_RD_DATA) is zero.
REG_WR_AKN	0	A change of register contents had been assigned through a process output.
	1	No change of register contents through a process output. (Write access REG_WR to the register interface is only possible, if this bit was zero before; handshake for data transfer to the registers).
REG_WR_ACCEPT	0	Writing the user data from the control interface to the register addressed with REG_WR_ADR in the control interface could not be done.
	1	Writing the user data from the control interface to the register addressed with REG_WR_ADR in the control interface was successful.
REG_RD_ADR	0 to 127	Address of the input register of which the content is shown in the user data (REG_RD_DATA) in the check-back interface if REG_RD_ABORT = 0.
User data		
REG_RD_DATA	0 ... $2^{32}-1$	Content of the register of which the address is transferred in the process input data (REG_RD_ADR) if REG_RD_ABORT = 0. If not, If not, REG_RD_DATA = 0.
AUX_REGx_RD_DATA	0 ... $2^{32}-1$	Value, which is read from the register with the address defined in the parameterization in ADR_AUX_REGx_RD_DATA.

11.4.4 Meaning of the process input bits of BL67-1CNT/ENC

Table 178:
Meaning of the
process input
bits of BL67-
1CNT/ENC,
alphabetically
sorted

Bit	Value	Meaning
A, B, Z	0	Digital input A, B or Z = 0
	1	Digital input A, B or Z = 1
AUX_RD_DATA	0 to $2^{32}-1$	Content of the register which has been defined via parameter byte 14 (see section „Meaning of the parameter bits of BL67-1CNT/ENC“).
DI0 to DI3	0	Digital input DIx = 0
	1	Digital input DIx = 1
ERR_PARA	0	The last change in parameters is valid.
	1	Faulty/ inconsistent parameter data.
REG_ACT_RD_ADR	0 to 127	Address of the actually read input register.
REG_RD_ABORT	0	REG_RD_ADR valid → The reading of the register defined in REG_RD_ADR has been accepted and executed. The content of the register can be found in the user data (REG_RD_DATA, byte 0-3).
	1	REG_RD_ADR error → Reading the register defined in REG_RD_ADR not accepted. The value in the user data area (REG_RD_DATA, byte 0-3) is zero.
REG_RD_DATA	0 to $2^{32}-1$	Content of the register selected by REG_RD_ADR. If RD_ABORT = 0, if not REG_RD_DATA = 0.
REG_WR_ACCEPT	0	REG_WR_ADR error → During REG_WR = 1 the register addressed in REG_WR_ADR in the control interface could not successfully be written with user data.
	1	REG_WR_ADR valid → During REG_WR = 1 the register addressed in REG_WR_ADR in the control interface could not successfully be written with user data.
REG_WR_AKN	0	No change in the in the registers → No change of register contents through a process output. A write access (REG_WR) to the register bank is only possible when this bit was previously zero; handshake for data transfer to the registers.
	1	Register contents updated → A change of register contents had been assigned through a process output.

Table 178:
 Meaning of the
 process input
 bits of BL67-
 1CNT/ENC,
 alphabetically
 sorted

Bit	Value	Meaning
STS_OFLW	1	Counter value exceeded upper limit of counter range.
STS_UFLW	1	Counter value below lower limit of counter range
STS_ZC	1	Counter value crossed zero value
SYNC_AKN	1	Encoder synchronized with zero-position.
count direction	0	Up
	1	Down

11.5 Parameter interface of the Encoder modules

11.5.1 Meaning of the parameter bits of BLxx-1SSI

Table 179:
 Meaning of the
 parameter bits
 of BLxx-1SSI,
 alphabetically
 sorted

ADefault-
 setting

Designation	Value	Description
DIS_ERR_SSI		Sensor idle data cable test
	0 A	Activate: ZERO test of data cable.
	1	Deactivate: After the last valid bit, a ZERO test of the data cable is not carried out.
INVALID_BITS_LSB		Invalid bits (LSB)
	0 to 15	Number of invalid bits on the LSB side of the position value supplied by the SSI encoder. The meaningful word width of the position value transferred to the module bus master is as follows: SSI_FRAME_LEN - INVALID_BITS_MSB - INVALID_BITS_LSB. The invalid bits on the LSB side are removed by shifting the position value to the right, starting with the LSB. INVALID_BITS_MSB + INVALID_BITS_LSB must always be less than SSI_FRAME_LEN. Default 0 bit = 0 _{hex} A

Table 179:
Meaning of the
parameter bits
of BLxx-1SSI,
alphabetically
sorted

Designation	Value	Description
INVALID_BITS_ MSB	Number of invalid bits (MSB)	
	0 to 7	Number of invalid bits on the MSB side of the position value supplied by the SSI encoder. The meaningful word width of the position value transferred to the module bus master is as follows: SSI_FRAME_LEN - INVALID_BITS_MSB - INVALID_BITS_LSB. The invalid bits on the MSB side are zeroed by masking the position value. INVALID_BITS_MSB +INVALID_BITS_LSB must always be less than SSI_FRAME_LEN.
SSI_BIT_RATE	Data rate	
	0	1000000 bps
	1	500000 bps
	2	250000 bps
	3	125000 bps
	4	100000 bps
	5	83000 bps
	6	71000 bps
	7	62500 bps
	8 to 15	reserved
SSI_CODE_G/D	0 A	SSI encoder sends data in binary code
	1	SSI encoder sends data in Gray code
SSI_FRAME_ LENGTH	Data frame bits	
	1 to 32	Number of bits of the SSI data frame. SSI_FRAME_LEN must always be greater than INVALID_BITS. Default: 25 = 19 _{hex} A

11.5.2 Meaning of the parameter bits of BL20-1CNT-24VDC

Table 180:
 Meaning of the
 parameter bits
 of BL20-1CNT-
 24VDC,
 alphabetically
 sorted

ADefault-
 setting

Designation	Value	Description
Diagnostic DOx	0 A	Diagnostic activated
	1	Diagnostic deactivated
Digital input DI	0 A	normal
	1	inverted
Substitute value DO	0 A	0
	1	1
Function DI	00 A	input
	01	HW gate
	10	Latch-Retrigger when edge pos. (only count operation)
	11	Synchronization when edge pos. (only count operation)
Function DOx	00 A	output
	01	– on when cnt value >= ref. value (count operation) – outside of limit (measurement operation)
	10	– on when cnt value <= ref. value (count operation) – below lower limit (measurement operation)
	11	– on when cnt value = ref. value (count operation) – above upper limit (measurement operation)
Sensor pulse per revolution	1 A to 65535	
Main count direction	00 A	None
	01	Up
	10	Down
Hysteresis	0 A to 255	Unsigned8
Pulse duration DOx	0 A to 255	[n*2ms], Unsigned8
integration time	1 to 1000	[n*10ms], 10 A
Measurement mode	100000	Frequency measurement A
	100001	Revolutions speed measurement
	100010	Period duration measurement
Upper limit	1 to 16777215 x 10 ⁻³	

Table 180:
Meaning of the
parameter bits
of BL20-1CNT-
24VDC,
alphabetically
sorted

Designation	Value	Description
Upper limit (HWORD)	0 A to 255	Unsigned8
Upper limit (LWORD)	0 A to 65535	
Upper count limit	0 to + 2147483647 ($2^{31}-1$)	
Upper count limit (HWORD)	0 to 32767 A	Unsigned16
Upper count limit (LWORD)	0 to 65535 A	Unsigned16
direction input (B)	0 A	normal
	1	inverted
group diagnostics	0 A	release
	1	block
sensor (A)	0 A	normal
	1	inverted
Sensor/ input filter (x)	0 A	2,5 μ s (200 kHz)
	1	25 μ s (20 kHz)
Signal evaluation (A, B)	00 A	pulse and direction
	01	rotary sensor: single
	10	rotary sensor: double
	11	rotary sensor: fourfold
Synchronization	0 A	single-action
	1	periodical
Gate function	0 A	abort count procedure
	1	interrupt count procedure
Lower limit	0 to 16 777 214 x 10^{-3}	
Lower limit (HWORD)	0 A to 255	Unsigned8
Lower limit (LWORD)	0 A to 65535	
Lower count limit	-2147483648 (-2^{31}) to 0	

Table 180:
 Meaning of the
 parameter bits
 of BL20-1CNT-
 24VDC,
 alphabetically
 sorted

Designation	Value	Description
Lower count limit (HWORD)	-32768 A to 0	Signed16
Lower count limit (LWORD)	-3 2 768 to 32 767	0 A , Signed16
Behaviour CPU/ master STOP	00 A	turn off DO1
	01	proceed with operating mode
	10	DO1 switch to substitute value
	11	DO1 hold last value
Counter mode	100000 A	continuous count
	100001	single counting
	100010	periodical counting

11.5.3 Meaning of the parameter bits of BL20-E-2CNT-2PWM

Table 181:
 Meaning of the
 parameter bits
 of BL20-E-2CNT-
 2PWM,
 alphabetically
 sorted

Bit	Value	Meaning
ADR AUX REGx WR DATA		Address of the basic write registers (Default: ADR AUX REG1 WR DATA = 0x60, ADR AUX REG2 WR DATA = 0x61, ADR AUX REG3 WR DATA = 0x70)
ADR AUX REGx RD DATA		Address of the basic read registers (Default: ADR AUX REG1 RD DATA = 0x20, ADR AUX REG2 RD DATA = 0x21, ADR AUX REG3 RD DATA = 0x40)
DBPx STS MODE	00 A	STS_DBPx = 1 at (REG_CNTx_CMP0) <= (REG_CNTx_CNT) < (REG_CNTx_CMP1)
	01	reserved
	10	
	11	STS_DBPx = Px

Table 181:
Meaning of the
parameter bits
of BL20-E-2CNT-
2PWM,
alphabetically
sorted

Bit	Value	Meaning
Diagnostic CNTx, Diagnostic PWMx	0	Diagnostic messages of the function unit activated in diagnostic interface A
	1	Diagnostic messages of the function unit deactivated in diagnostic interface A
Input Ax, Input Bx, Input Zx,	0 A	Signal logic remains (LOW = 0 / HIGH = 1)
	1	Invert signal before processing
Substitute value Px, Dx	0 A	The output of the substitute value depends on the parameterization of the used gateway (see documentation for the BL20-gateways).
Filter Ax, Bx	00	2 μ s A
	01	16 μ s
	10	reserved
	11	
Filter Zx	00	2 μ s A
	01	16 μ s
	10	reserved
	11	
Main count direction CNTx	00	Basic function A
	01	None
	10	Up
	11	Down
Measurement mode CNTx	0	Frequency measurement A
	1	Period duration measurement

Table 181:
 Meaning of the
 parameter bits
 of BL20-E-2CNT-
 2PWM,
 alphabetically
 sorted

Bit	Value	Meaning
Mode CNTx	0000 A	Pulse direction, single sample
	0001	Pulse direction, double sample
	0010	AB mode, single sample
	0011	AB mode, double sample
	0100	AB mode, four samples
	0101 to 1110	reserved
	1111	AB only input
Mode Dx		Definition of the function for Dx (Default = 11 1111 → simple output, can be controlled via process data) Please find additional assignment in the general module documentation (Turck-documentation number: D301224)
Mode PWMx	0000 A	PD DC Definition:
	0001	HT LT Definition
	0010 to 0111	reserved
	1111	P just output
Mode Zx	0000	Alarm input CNT
	0001 A	HW gate CNT
	0010	Single Latch-Retrigger CNT
	0011	Continuous latch retrigger CNT
	0100	Single L.-R. and HW gate CNT
	0101	Continuous L.-R. and HW gate CNT
	0110	reserved
Pull Up Zx	0 A	Pull Up resistance 20 kΩ off
	1	Pull Up resistance 20 kΩ on
Threshold input A,B,Z CNTx	0 A	Threshold 7.5V (only valid for Ax, Bx, Zx)
	1	Threshold 2.5V (only valid for Ax, Bx, Zx)

11.5.4 Meaning of the parameter bits of BL67-1CNT/ENC

Table 182:
Meaning of the
parameter bits
of BL67-1CNT/
ENC,
alphabetically
sorted

Bit	Value	Meaning
Input x	0 A	normal
	1	inverted
Input filter (A, B)	00 A	500 kHz
	01	50 kHz
	10	5 kHz
	11	reserved
Function DI3	0 A	input
	1	encoder-GND
Function DO3	0 A	output
	1	encoder power supply
Encoder signal	0 A	Push-pull input (single ended): Signal evaluation between A, B, Z and GND. The inputs /A, /B and /Z are internally connected to GND.
	1	RS422-input: Signal evaluation between A, B, Z and /A, /B, /Z
Measurement mode	0 A	Frequency measurement
	1	Period duration measurement
PullUp Z	0 A	The PullUp-resistance for input Z is switched off.
	1	The PullUp-resistance for input Z is switched on.
REG_AUX_ADR	0 to 127 Default: 48 A	Definition of the register number from the register interface (REG_PARA; REG_COUNTER_VALUE, REG_LOWER_LIMIT etc.), whose content should be mapped into byte 8 - 11 of the process input data.
Signal evaluation (A, B)	00	1 x: rising edge at A
	01	1 x: falling edge at A
	10 A	2 x: both edges at A
	11	4 x: both edges at A and B (only incremental encoders)

Table 182:
 Meaning of the
 parameter bits
 of BL67-1CNT/
 ENC,
 alphabetically
 sorted

Bit	Value	Meaning
Threshold input A, B, Z	0000	1V
	0001	1,5 V
	0010	2 V
	0011	2,5 V
	0100	3 V
	0101	4 V
	0110	5 V
	0111	6 V
	1000	7 V
	1001	8 V
	1010	9 V
	1011 A	10 V
	1100	12 V
	1101	14 V
	1110	16 V
1111	18 V	
Synchronization with Z	0 A	single-action If a signal is pending at Z and if, at the same time, the bit SYNC_REQ = 1 (see section „Meaning of the process output bits of BL67-1CNT/ENC“ control interface: byte 1, bit 6), then the counter is synchronized once with the load value.
	1	periodical If a signal is pending at Z and if, at the same time, the bit SYNC_REQ = 1 (see section „Meaning of the process output bits of BL67-1CNT/ENC“ control interface: byte 1, bit 6), then the counter is synchronized once with the load value.
Gate	0 A	normal
	1	inverted
Gate function	000	Counter permanently inactive
	001	DI0 is HW-gate
	010	DI1 is HW-gate
	011	DI2 is HW-gate
	100	DI3 is HW-gate
	101	Z is gate
	110 A	only SW-gate
	111	reserved
Count mode	0 A	encoder
	1	pulse and direction

Table 182:
Meaning of the
parameter bits
of BL67-1CNT/
ENC,
alphabetically
sorted

Bit	Value	Meaning
Count direction	0 A	Up
	1	Down

11.6 Diagnostic interface of the Encoder modules

11.6.1 Meaning of the diagnostic bits of BLxx-1SSI

Table 183:
Meaning of the
diagnostic bits
of BLxx-1SSI,
alphabetically
sorted

Designation	Value	Description
ERR_PARA	0	The parameter set of the module has been accepted.
	1	Operation of the module is not possible with the present parameter set.
ERR_SSI	0	SSI encoder signal present.
	1	SSI encoder signal faulty. (e.g. due to a cable break).
SSI_DIAG	0	No enabled status signal is active (SSI_STSx = 0).
	1	At least one enabled status signal is active (SSI_STSx = 1).
SSI_OFLW	0	SSI encoder value below / equal to upper limit.
	1	SSI encoder value above upper limit. Overflow occurred.
SSI_UFLW	0	SSI encoder value above / equal to lower limit.
	1	SSI encoder value below lower limit. Underflow occurred.

11.6.2 Meaning of the diagnostic bits of BL20-1CNT-24VDC

Table 184:
 Meaning of the
 diagnostic bits
 of BL20-1CNT-
 24VDC,
 alphabetically
 sorted

Designation	Description
Count operation	
ERR_24Vdc	Short-circuit sensor supply: This diagnostics information must be acknowledged with the EXT_F_ACK (see Meaning of the process output bits of BL20-1CNT-24VDC (page 11-53)) control bit.
ERR_DO	Short-/open circuit/excess temperature at the output DO1: This diagnostics information must be acknowledged with the EXT_F_ACK (see Meaning of the process output bits of BL20-1CNT-24VDC (page 11-53)) control bit.
ERR_PARA	<p>Bit 2: End of counter range wrong The following parameter errors are indicated: Upper count limit = lower count limit Upper count limit \leq lower count limit Upper count limit 0</p> <p>Bit 3: Start of counter range wrong Lower count limit = upper count limit Lower count limit \geq upper count limit lower count limit 0</p> <p>Bit 4: Invert-DI+latch-retr. not perm. It is not permitted to invert the level of the digital input when using the latch-retrigger-function</p> <p>Bit 5: Main count direction wrong Wrong parameter value for defining the main count direction (Object 5800hex – Encoder Basic Mode (page 11-6), byte 1, bit 5 and 6). Permissible values: 00 = none 01 = up 10 = down</p>
OPER._MODE	Wrong parameter value for defining the operation mode (Object 5800hex – Encoder Basic Mode (page 11-6) , byte 0, bit 0-5).
Measurement mode	
ERR_24Vdc	see above
ERR_DO	see above

Table 184:
Meaning of the
diagnostic bits
of BL20-1CNT-
24VDC,
alphabetically
sorted

Designation	Description
ERR_PARA	Bit 2: Sensor pulse wrong
	Bit 3: Integration time wrong The value for the integration time is incorrect Object 5820hex – Measuring Integration Time (page 11-22) . Permissible value range: 1 to 1000
	Bit 4: Upper limit wrong The value for the upper limit time is incorrect . Permissible value range: 1 to 16777215
ERR_PARA	Bit 5: Lower limit wrong The value for the lower limit time is incorrect . Permissible value range: 0 to 16777214
OPER._MODE	Wrong parameter value for defining the operation mode (Object 5800hex – Encoder Basic Mode (page 11-6) , byte 0, bit 0-5).
MEAS._MODE	This message is always shown in conjunction with other diagnostics messages and indicates that messages refer to an active measurement mode.

11.6.3 Meaning of the diagnostic bits of BL20-E-2CNT-2PWM

Table 185:
Diagnostics of
the BL20-E-
2CNT-2PWM

Diagnostic message	Values	Meaning
CNT1_PAR_ERR, CNT2_PAR_ERR, PWM1_PAR_ERR, PWM2_PAR_ERR	0	Parameter set of function unit correct
	1	Faulty / inconsistent parameters, wrong parameterization
P1_DIAG, P2_DIAG, D1_DIAG, D2_DIAG	0	No diagnostic message
	1	Diagnosis pending at channel (short circuit)
HW_ERR	0	No diagnostic message
	1	"Hardware error" Display of common errors of the module's hardware (e.g. CRC-error, adjustment error....). Change of device necessary.

11.6.4 Meaning of the diagnostic bits of BL67-1CNT/ENC

Table 186:
 Meaning of
 the diagnostic
 bits of BL67-
 1CNT/ENC,
 alphabetically
 sorted

Diagnostic message	Values	Meaning
STS_OFLW	0	no overflow
	1	Counter value exceeded upper limit of counter range.
STS_UFLW	0	no underflow
	1	Counter value below lower limit of counter range.
DIA_DOx	0	output OK
	1	Short circuit or overload at output x
ERR_PARA	0	The last change in parameters is valid.
	0	Faulty/ inconsistent parameter data.

12 Objects for SWIRE modules

12.1	Motor starter modules BL20	2
12.2	General object overview for SWIRE modules	2
12.2.1	Representation of process input data	3
	– Process input.....	3
12.2.2	Representation of process output data.....	4
	– Process output	5
12.2.3	Representation of diagnostic data	6
12.2.4	Representation of parameter data.....	10
	– Object 3064 _{hex} – XBI Param Dword	13
	– Object 3065 _{hex} – XBI Param Dword	14
	– Object 3066 _{hex} – XBIParam Dword3	14
	– Object 3067 _{hex} – XBIParam Dword4	14
	– Object 3068 _{hex} – XBIParam Dword5	15
	– Object 3069 _{hex} – XBIParam Dword6	15

12.1 Motor starter modules BL20

The objects are used in the following modules:

<i>Table 187: BL20 - motor starter modules</i>	Product family	Module
	BL20	BL20-E-1SWIRE

12.2 General object overview for SWIRE modules

<i>Table 188: General object overview for SWIRE modules</i>	Object	Name	page
	Input data		
	6000 _{hex}	Read Input 8 bit	page 5-4
	...		
	6120 _{hex}	Read Input 32 bit	page 5-6
	Output data		
	6200 _{hex}	Write Output 8 bit	page 6-4
	...		
	6320 _{hex}	Write Output 32 bit	page 6-12
	Diagnostic data		
	3040 _{hex}	XBIDiag Byte	page 14-8ff.
	3042 _{hex}	XBIDiag Word	
	3044 _{hex}	XBIDiag Dword	
	3045 _{hex}	XBIDiag Dword2	
	3046 _{hex}	XBIDiag Dword3	
	3047 _{hex}	XBIDiag Dword4	
	Parameter data		
	3060 _{hex}	XBIParam Byte	page 14-9ff.
	3062 _{hex}	XBIParam Word	
	3064 _{hex}	XBIParam DWord	
	3065 _{hex}	XBIParam DWord2	
	...		
	306B _{hex}	XBIParam Dword8	

12.2.1 Representation of process input data

The process input data of the SWIRE modules is represented by objects 6000_{hex}, 6020_{hex}, 6021_{hex} and 6022_{hex}, 6100_{hex} or 6120_{hex} for **digital input channels** of a station.

The user can choose between 4 different formats for representing the values:

- Only one bit represented by each SUB-index (objects 6020_{hex}, 6021_{hex} and 6022_{hex}), see page . [page 5-5](#)
- 8 bits represented by each SUB-index (object 6000_{hex}), [page 5-5](#)
- 16 bits represented by each SUB-index (object 6100_{hex}), [page 5-5](#)
- 32 bits represented by each SUB-index (object 6120_{hex}), [page 5-5](#)

PDO mapping of object 6000_{hex} is always executed by default and automatically for the first 8 sub-indexes. This corresponds to the 64 bits of the SWIRE feedback interface. If more than 64 process input data items are present, the PDO mapping must be carried out by the user. A total of 36 groups of 8 bits each can be displayed (288 bits).

If the representation of the data bits is **not** required with the object 6000_{hex} or if another arrangement of the mapped objects is required, PDO mapping must be carried out by the user.

Process input

The field input data is transferred from the connected SWIRE-BUS to the SWIRE module. The process input data is the data that is transferred by the SWIRE module via a gateway to the PLC. The transfer is carried out in 8-byte format. 4 bits are reserved for each SWIRE slave. The following information can be transferred:

- Contactor coil on/off
- Motor-protective circuit-breaker off or tripped/ on
- Status of the slave o.k./diagnostics message present

	Bit 7	Bit 6	Bit 5	Bit 4	Bit 3	Bit 2	Bit 1	Bit 0
Byte 0	SWIRE-Slave 2				SWIRE-Slave 1			
Byte 1	SWIRE-Slave 4				SWIRE-Slave 3			
Byte 2	SWIRE-Slave 6				SWIRE-Slave 6			
Byte 3	SWIRE-Slave 8				SWIRE-Slave 7			
Byte 4	SWIRE-Slave 10				SWIRE-Slave 9			
Byte 5	SWIRE-Slave 12				SWIRE-Slave 11			
Byte 6	SWIRE-Slave 14				SWIRE-Slave 13			
Byte 7	SWIRE-Slave 16				SWIRE-Slave 15			

The data of SWIRE slave 1 is the data of the first physical slave on the SWIRE bus. The remaining slaves are assigned in consecutive order accordingly. The meaning of the data of an SWIRE slave depends on the product concerned.

Meaning of the 4-bit process input data on an SWIRE-DIL device:

Bit 7	Bit 6	Bit 5	Bit 4
SDx / free	free	PKZSTx	Slx

The following table shows the meaning of the data bits:

Table 189:
Meaning of the
data bits

Designation	Status	Comment
Slx Switch status, relay x		
Slx supplies the switch status of the contactor coil of the SWIRE bus slave as a feedback signal. Slx makes it possible to check whether the set switch status was executed by a mechanical connection. This must take into account the time delay between the setting of an output, a mechanical execution and the subsequent feedback signal.		
0	OFF	Contactor coil is switched off
1	ON	Contactor coil is switched on
PKZSTx Switch status, PKZ x		
0	OFF	The motor-protective circuit breaker is off or has tripped
1	ON	The motor-protective circuit breaker is switched on
SDx Communication error, slave x		
Setting the NDDIAG parameter copies the slave diagnostics message (input byte 1/bit 3) to the feed-back interface. The information is provided as status information in the PLC for the user.		
0	ON LINE	Status of slave x:
1	OFF LINE	Status of slave x: diagnostics available

12.2.2 Representation of process output data

The process input data of the SWIRE modules is represented by objects 6200_{hex}, 6220_{hex}, 6221_{hex}, and 6222_{hex}, 6300_{hex} or 6320_{hex} for **digital input channels** of a station.

The user can choose between 4 different formats for representing the values:

- Only one bit represented by each SUB-index (objects 6220_{hex}, 6221_{hex} and 6222_{hex}), [page 6-7 ff.](#)
- 8 bits represented by each SUB-index (object 6200_{hex}), [page 6-4.](#)
- 16 bits represented by each SUB-index (object 6300_{hex}), [page 6-10.](#)
- 32 bits represented by each SUB-index (object 6320_{hex}), [page 6-12.](#)

PDO mapping of object 6200_{hex} is always executed by default and automatically for the first 8 sub-indexes. This corresponds to the 64 bits of the SWIRE control interface. If more than 64 process output data items are present, the PDO mapping must be carried out by the user. A total of 36 groups of 8 bits each can be displayed (288 bits).

If the representation of the data bits is **not** required with the object 6200_{hex} or if another arrangement of the mapped objects is required, PDO mapping must be carried out by the user.

Process output

Field output data is output from an SWIRE module to a field device. The process output data is the data that is transferred by the PLC via a gateway to the SWIRE module. The transfer is carried out in 8-byte format. 4 bits are reserved for each SWIRE slave. The following information is transferred:

Switch status of contactor coil on/off

	Bit 7	Bit 6	Bit 5	Bit 4	Bit 3	Bit 2	Bit 1	Bit 0
Byte 0	SWIRE-Slave 2				SWIRE-Slave 1			
Byte 1	SWIRE-Slave 4				SWIRE-Slave 3			
Byte 2	SWIRE-Slave 6				SWIRE-Slave 6			
Byte 3	SWIRE-Slave 8				SWIRE-Slave 7			
Byte 4	SWIRE-Slave 10				SWIRE-Slave 9			
Byte 5	SWIRE-Slave 12				SWIRE-Slave 11			
Byte 6	SWIRE-Slave 14				SWIRE-Slave 13			
Byte 7	SWIRE-Slave 16				SWIRE-Slave 15			

The data of SWIRE slave 1 is the data of the first physical slave on the SWIRE bus. The remaining slaves are assigned in consecutive order accordingly. The meaning of the data of an SWIRE slave depends on the product concerned.

Meaning of the 4-bit process output data on an SWIRE-DIL device:

Bit 7	Bit 6	Bit 5	Bit 4
free	free	free	SOx

The following table shows the meaning of the data bits:

<i>Table 190: Meaning of the data bits</i>	Designation	Status	Comment
	SOx	relay x relay x	
			SOx is transferred as the switch status of the contactor coil from the SWIRE bus master to the appropriate SWIRE bus slave.
		0	OFF Contactor not switched on
		1	ON Contactor switched on

12.2.3 Representation of diagnostic data

The 8 bytes of diagnostics data for the SWIRE module are represented by the manufacturer specific objects 3044_{hex} „XBIDiag Dword“ and 3045_{hex} „XBIDiag Dword2“ of the CANopen gateway.

A sub-index of these objects can represent a maximum number of 4 bytes. Larger diagnostics data volumes are distributed on the following objects. The sub-index also belongs to the module number.

The following table shows the assignment of the parameter data bytes of the SWIRE-module to the manufacturer specific objects:

Byte- No.	0	1	2	3	4	5	6	7	8	9	10	11	12	13	14	15
	8 Diagnostic bytes of the SWIRE-module								free							
Object- no. in (hex)	3044 (see page 14-8)				3045 (see page 14-8)				3046				3047			

Use the objects 3044_{hex} and 3045_{hex} to access all the diagnostics data. The **sub-index** of the objects has to correspond to the slot-number of the module in the station.

	Bit 7	Bit 6	Bit 5	Bit 4	Bit 3	Bit 2	Bit 1	Bit 0
Byte 1	GENERAL _{ERR}	U _{SWERR}	free	COM _{ERR}	free	RDY _{ERR}	free	SW _{ERR}
Byte 2	free	U _{AUXERR}	TYP _{ERR}	free	PKZ _{ERR}	free	SD _{ERR}	free
TYP_{ERR} field								
Byte 3	TYP _{ERR}	TYP _{ERR} S7	TYP _{ERR} S6	TYP _{ERR} S5	TYP _{ERR} S4	TYP _{ERR} S3	TYP _{ERR} S2	TYP _{ERR} S1
Byte 4	TYP _{ERR} S16	TYP _{ERR} S15	TYP _{ERR} S14	TYP _{ERR} S13	TYP _{ERR} S12	TYP _{ERR} S11	TYP _{ERR} S10	TYP _{ERR} S9
Slave diagnostics bit field								
Byte 5	SD _{ERR} S8	SD _{ERR} S7	SD _{ERR} S6	SD _{ERR} S5	SD _{ERR} S4	SD _{ERR} S3	SD _{ERR} S2	SD _{ERR} S1
Byte 6	SD _{ERR} S16	SD _{ERR} S15	SD _{ERR} S14	SD _{ERR} S13	SD _{ERR} S12	SD _{ERR} S11	SD _{ERR} S10	SD _{ERR} S9
PKZ field								
Byte 7	PKZ _{ERR} S8	PKZ _{ERR} S7	PKZ _{ERR} S6	PKZ _{ERR} S5	PKZ _{ERR} S4	PKZ _{ERR} S3	PKZ _{ERR} S2	PKZ _{ERR} S1
Byte 8	PKZ _{ERR} S16	PKZ _{ERR} S15	PKZ _{ERR} S14	PKZ _{ERR} S13	PKZ _{ERR} S12	PKZ _{ERR} S11	PKZ _{ERR} S10	PKZ _{ERR} S9

The following table shows the meaning of the diagnostic bits:

Byte	Design.	Status	Comment
Byte 1	SW _{ERR}	SWIRE MASTER	
		The configuration was accepted according to the parameter setting and the SWIRE bus is in data exchange mode.	
		0	Data exchange The bus is in data exchange mode
	1	Offline The configuration was not accepted, the bus does not switch to data exchange mode. (SW LED flashing)	
	RDY _{ERR}	SPS SLAVE	
		Parameter setting is faulty. The ACTUAL configuration was accepted according to the SET configuration and the data exchange with the higher-level is o.k.	
0		Data exchange The bus is in data exchange mode	
1	Offline The configuration was not accepted, the bus does not switch to data exchange mode. (Rdy LED flashing)		
COM _{ERR}	Communication SWIRE		
	A communication error is present, such as a slave is no longer reached, its internal timeout has elapsed or communication is faulty. The master cannot carry out data exchange with at least one slave.		
	0	OK No error present.	
1	faulty An error is present		
U _{SWERR}	Voltage U_{sw}		
	Voltage fault in U _{sw} , voltage (17 V DC) for supplying the SWIRE slaves		
	0	OK No error present.	
1	under voltage An error is present		
GENERAL _{ERR}	Error message		
	The creation of a function block shows that systems/function blocks for the general checking of a slave for any diagnostics messages present only check the first byte.		
	0	None No diagnostics message present	
1	present One/several diagnostics messages present		
Byte 2	SD _{ERR}	Communication SWIRE slave	
		If the parameter SD _{ERR} A is set for group diagnostics, this bit indicates an error as soon as only one slave on the bus sets its SD error bit.	
		0	OK No error is present or diagnostics function has been deactivated via the parameter setting.
1	faulty An error is present		

Byte	Design.	Status	Comment
	PKZ _{ERR}	Overcurrent protective circuit-breaker	
		If the parameter PKZ _{ERR} A is set for group diagnostics, this bit indicates an error as soon as only one PKZ of a slave has tripped.	
		0	OK No PKZ has tripped or diagnostics function has been deactivated via the parameter setting.
		1	tripping At least one PKZ has tripped.
	TYP _{ERR}	Configuration	
		If the TYP _{ERR} parameter is set for group diagnostics, this bit indicates an error as soon as the ACTUAL configuration of a slave does not match the SET configuration for this position.	
		0	OK The ACTUAL configuration fully matches the SET configuration or diagnostics function has been deactivated via the parameter.
		1	faulty The actual configuration does not fully match set configuration.
	U _{AUXERR}	Voltage U _{AUX}	
		If the U _{AUXERR} A parameter is activated, U _{AUXERR} will generate an error message as soon as the power supply goes below the level at which the function of the relays is not guaranteed.	
		0	OK Contactor supply voltage is o.k. (> 20 VDC) or diagnostics function has been deactivated via this parameter.
		1	under voltage Contactor supply voltage is not o.k. (< 18 VDC).
Byte 3.4	TYP _{ERR} Sx	Device configuration, slave x	
		Info field for the individual indication of a configuration error as error message. If the TYP _{INFO} A parameter has been set for single diagnostics, this bit field indicates the error, as soon as the ACTUAL configuration of the slave was not accepted and is therefore not enabled for data exchange. The diagnostics LED of the slave flashes.	
		0	OK No configuration error is present and the slave is in data exchange mode or diagnostics function has been deactivated via the parameter setting.
		1	incorrect No configuration error present and the slave is NOT in data exchange mode.
Byte 5.6	SD _{ERR} Sx	Communication, slave x	
		Info field for the individual indication of the release of the slave diagnostics as error message. If the SD _{INFO} A is set for single diagnostics, this bit field indicates the error as soon as the slave diagnostic message of the slave Sx is triggered.	
		0	OK No error is present or diagnostics function has been deactivated via the parameter setting.
		1	Offline A diagnostics message is present.

Byte	Design.	Status	Comment
Byte 7.8	PKZ _{ERR} -Sx	Overcurrent protective circuit-breaker, slave x	
		Info field for the individual indication of the tripping a motor-protective circuit-breaker (PKZ) as error message. If the PKZ _{INFO} A is set for single diagnostics, this bit field indicates the error as soon as the PKZ of the slave Sx has tripped.	
		0	OK
			The PKZ of the slave has not tripped or diagnostics function has been deactivated via the parameter setting.
		1	tripped
			The PKZ of the slave has tripped.

12.2.4 Representation of parameter data

The 24 bytes of parameter data for the SWIRE module are represented by the manufacturer specific objects 3064_{hex} „XBIPParam Dword“ to 3069_{hex} „XBIPParam Dword6“ of the CANopen gateway.

A sub-index of these objects can represent a maximum number of 4 bytes. Larger parameter data volumes are distributed on the following objects. The sub-index also belongs to the module number.

The following table shows the assignment of the parameter data bytes of the SWIRE module to the manufacturer specific objects:

Byte no.	0	1	2	3	4	5	6	7
Object no.	Parameter bytes 0 to 7 of the SWIRE-module							
	3064 _{hex} (see page 14-10)				3065 _{hex} (see page 12-13)			
Byte no.	8	9	10	11	12	13	14	15
Object no.	Parameter bytes 8 to 15 of the SWIRE-module							
	3066 _{hex} (see page 12-13)				3067 _{hex} (see page 12-13)			
Byte no.	16	17	18	19	20	21	22	23
Object no.	Parameter bytes 16 to 23 of the SWIRE-module							
	3068 _{hex} (see page 12-13)				3069 _{hex} (see page 12-13)			

Use the objects 3064_{hex} and 3069_{hex} to access all the parameter data. The sub-index of the objects has to correspond to the slot-number of the module in the station.

The structure of the parameter data will be described in the following:

	Bit 7	Bit 6	Bit 5	Bit 4	Bit 3	Bit 2	Bit 1	Bit 0
Byte 1	reserved	free	free	free	MNA	Configura tion	Disable Cfg	free
Byte 2	free	U _{AUXERR}	TYP _{ERR}	TYP _{INFO}	PKZ _{ERR}	PKZ _{INFO}	SD _{ERR}	SD _{INFO}
Byte 3	reserved							
Byte 4	Life guarding time							
Byte 5	SD _{DIAG} S8	SD _{DIAG} S7	SD _{DIAG} S6	SD _{DIAG} S5	SD _{DIAG} S4	SD _{DIAG} S3	SD _{DIAG} S2	SD _{DIAG} S1
Byte 6	SD _{DIAG} S16	SD _{DIAG} S15	SD _{DIAG} S14	SD _{DIAG} S13	SD _{DIAG} S12	SD _{DIAG} S11	SD _{DIAG} S10	SD _{DIAG} S9
Byte 7	reserved							
Byte 8	reserved							
Byte 9 - 24	Type designation slave 1 - 16							

The following table shows the meaning of the parameter bits:

Table 191:
Module
parameters

	Parameter name	Value	
	Byte 1		
A Default-setting	Disable Cfg	Disabling of the acceptance of the physically present configuration as ACTUAL configuration on manual pushbutton actuation.	
		0 = inactive A	The physically present configuration of the SWIRE bus is only accepted as the ACTUAL configuration by pressing the CFG button. The comparison with the SET configuration is then carried out.
		1 = active	The physically present configuration is automatically accepted as the ACTUAL configuration and then compared with the SET configuration.
	Configuration	PLC configuration check The configuration check parameter enables a comparison of the set and actual configuration based on the device ID.	
		0 = active A	Configuration check based on device ID. Only SWIRE slaves with a device ID completely matching the set configuration are accepted on the bus.
		1 = inactive	All slaves are mapped in 4Bit INPUT/ 4Bit OUTPUT without checking the device ID.
	MNA active/ passive	Configuration check If the ACTUAL configuration of the SWIRE bus does not match the SET configuration, the master only exchanges data with the correctly configured and functional slaves.	
		0 = Bus based A	No data exchange with a slave with an incomplete / incorrect configuration.
		1 = Slave based	The bus also goes into operation with the correctly configured slaves even if the configuration is incomplete. All slaves detected by the daisy chain configuration with a position that matches the set configuration are started up. Slaves that do not match the set configuration are inactive.
	SD _{INFO}	Slave error field Activate slave diagnostics info field SD _{ERR} Sx. As soon as a slave on the bus sets its error bit, this is indicated individually as an error depending on the parameter setting.	
active		Single diagnostics is activated	
inactive		Single diagnostics is not activate	

Table 191:
Module
parameters

	Parameter name	Value
	Byte 2	
A Default-setting	SD _{ERR}	Group error - slave error Activate slave diagnostics SD _{ERR} Sx. As soon as only one slave on the bus sets its error bit, this is indicated as a group error depending on the parameter setting.
		0 = active A Group diagnostics is activated
		1 = inactive Group diagnostics is not activated
	PKZ _{INFO}	PKZ error field Activate slave diagnostics info field PKZ _{ERR} Sx. As soon as a slave on the bus clears its PKZ bit, this is indicated as an individual error depending on the parameter setting.
		0 = active A Single diagnostics is activated
		1 = inactive Single diagnostics is not activate
	PKZ _{ERR}	Group PKZ error field Activate slave diagnostics PKZ _{ERR} Sx. As soon as a slave on the bus clears its PKZ bit, this is indicated as an individual error depending on the parameter setting.
		0 = active A Single diagnostics is activated
		1 = inactive Single diagnostics is not activate
	TYP _{INFO}	Configuration error field As soon as a slave on the bus does not match the set configuration and therefore cannot be started, this is indicated as an individual error depending on the parameter set.
		0 = active A Single diagnostics is activated
		1 = inactive Single diagnostics is not activate
TYP _{ERR}	Group configuration error field Activate slave diagnostics TYP _{ERR} Sx. As soon as only one slave on the bus is incorrectly configured, this is indicated as an error depending on the parameter setting.	
	0 = active A Group diagnostics is activated	
	1 = inactive Group diagnostics is not activated	
U _{AUXERR}	Error message Voltage U _{AUX} Activate system diagnostics U _{AUXERR} . U _{AUXERR} will generate an error message as soon as the power supply goes below a level at which the function of the relays is not guaranteed.	
	0 = active A Error message U _{AUXERR} activated	
	1 = inactive Error message U _{AUXERR} not activated	
	Byte 3	reserved

Table 191:
Module
parameters

Parameter name	Value	
Byte 4		
Lifeguarding	0x02-0xFF 0x64 A	Lifeguarding time of the SWIRE slaves Setting of lifeguarding time of SWIRE slaves , timeout time up to automatic reset of the slaves in the event of communication failure. (n × 10ms) (Default 1s) 0xFF: Lifeguarding off
Byte 5, 6		
SD _{DIAG} Sx	Input bit communication error, slave x Slave diagnostics message from Byte 1 / Bit 7 is accepted in the feedback interface as Bit 4	
	0 = active A	SD _{DIAG} Sx is accepted
	1 = inactive	SD _{DIAG} Sx is not accepted
Byte 7, 8	reserved	
Byte 9 to 24		
Device ID, slave x	TYPE setting for the LIN slave at position x on the SWIRE bus	
	0x20	SWIRE-DIL-MTB (: 0xFF)
	0xFF	Basic setting (no slave)

Object 3064_{hex} – XBI Param Dword

The object XBIParam Dword reads the first Param-Dword (byte 0...3) of a module on the module bus. The sub-index 1 to 74 corresponds to the module number of the module in the station.

Table 192:
Object 3064_{hex}

Feature	Description
Name	XBIParam Dword
Object code	ARRAY
PDO mapping	No
Data type	Unsigned32
Access	rw
Default value	No

Object 3065_{hex} – XBI Param Dword

The object XBIParam Dword reads the first Param-Dword (byte 4..0.7) of a module on the module bus. The sub-index 1 to 74 corresponds to the module number of the module in the station.

Table 193:
Object 3065_{hex}

Feature	Description
Name	XBIParam Dword2
Object code	ARRAY
PDO mapping	No
Data type	Unsigned32
Access	rw
Default value	No

Object 3066_{hex} – XBIParam Dword3

The object XBIParam Dword3 reads the third Param-Dword (byte 8..11) of a module on the module bus. The sub-index 1 to 74 corresponds to the module number of the module in the station.

Table 194:
Object 3066_{hex}

Feature	Description
Name	XBIParam Dword3
Object code	ARRAY
PDO mapping	No
Data type	Unsigned32
Access	rw
Default value	No

Object 3067_{hex} – XBIParam Dword4

The object XBIParam Dword4 reads the fourth Param-Dword (byte 12..15) of a module on the module bus. The sub-index 1 to 74 corresponds to the module number of the module in the station.

Table 195:
Object 3067_{hex}

Feature	Description
Name	XBIParam Dword4
Object code	ARRAY
PDO mapping	No
Data type	Unsigned32
Access	rw
Default value	No

Object 3068_{hex} – XBIParam Dword5

The object XBIParam Dword5 reads the fifth Param-Dword (byte 16...19) of a module on the module bus. The sub-index 1 to 74 corresponds to the module number of the module in the station.

Table 196:
Object 3068_{hex}

Feature	Description
Name	XBIParam Dword5
Object code	ARRAY
PDO mapping	No
Data type	Unsigned32
Access	rw
Default value	No

Object 3069_{hex} – XBIParam Dword6

The object XBIParam Dword6 reads the first Param-Dword (byte 20...24) of a module on the module bus. The sub-index 1 to 74 corresponds to the module number of the module in the station.

Table 197:
Object 3069_{hex}

Feature	Description/ Value
Name	XBIParam Dword6
Object code	ARRAY
PDO mapping	No
Data type	Unsigned32
Access	rw
Default value	No

13 Objects for RFID-modules

13.1	RFID-S-module BL20	2
13.2	General object overview for RFID-S-modules	2
13.3	Object 5700 _{hex} - 8 byte process input data	2
13.4	Object 5701 _{hex} - 12 byte process input data	3
13.5	Object 5702 _{hex} - 8 byte process output data	3
13.6	Object 5703 _{hex} - 12 byte process output data	4
13.7	Object 5708 _{hex} - 1 byte status messages	4
13.8	Object 5722 _{hex} - 1 byte parameter	5

13.1 RFID-S-module BL20

The objects are used in the following modules:

Product family	Module
BL20	BL20-2RFID-S

13.2 General object overview for RFID-S-modules

Object	Name	page
5700 _{hex}	8 byte process input data	Seite 13-2
5701 _{hex}	12 byte process input data	Seite 13-3
5702 _{hex}	8 byte process output data	Seite 13-3
5703 _{hex}	12 byte process output data	Seite 13-4
5708 _{hex}	1 byte status messages	Seite 13-4
5722 _{hex}	1 byte parameters	Seite 13-5

13.3 Object 5700_{hex} - 8 byte process input data

The first 8 bytes of the process input data of a BL ident[®]-channel are displayed in Object 5700_{hex}.

Thus the range of the read-data is limited to 4byte. The 8 byte transfer format consists of the following:

- 1 byte status messages
- 2 byte error code
- 1 byte reserved
- 4 byte read data

Feature	Description
Name	RS232/RS4xx parameters
Object code	ARRAY
Data type	Unsigned32
Access	rw
Default value	No
PDO mapping	Yes

13.4 Object 5701_{hex} - 12 byte process input data

The 12 byte of the "Process Input Data" of BL ident °-channel are displayed in object_{hex}.

The 12 byte transfer format consists of the following:

- 1 byte status messages
- 2 byte error code
- 1 byte reserved
- 8 byte read data

Table 201:
Object 5701_{hex}

Feature	Description
Name	RFID Input Data Segmented
Object code	ARRAY
Data type	Domain
Access	ro
Default value	No
PDO mapping	No

13.5 Object 5702_{hex} - 8 byte process output data

The 8 byte of the "Process output Data" of BL ident °-channel are displayed in object 5702_{hex}.

The 8 byte transfer format consists of the following:

- 4 byte command and control bits
- 4 byte write data

Table 202:
Object 5702_{hex}

Feature	Description
Name	RFID Output Data U64
Object code	ARRAY
Data type	Unsigned64
Access	rw
Default value	No
PDO mapping	Yes

13.6 Object 5703_{hex} - 12 byte process output data

The 12 byte of the "Process output Data" of BL ident °-channel are displayed in object 5703_{hex}.

The 12 byte transfer format consists of the following:

- 4 byte command and control bits
- 8 byte write data

Table 203:
Object 5703_{hex}

Feature	Description
Name	RFID Output Data Segmented
Object code	ARRAY
Data type	Domain
Access	rw
Default value	No
PDO mapping	No

13.7 Object 5708_{hex} - 1 byte status messages

1 byte of the "Process Input Data" of BL ident °-channel is displayed in 5708_{hex}. This byte contains all status messages (DONE, BUSY, ERROR...):

The 12 byte transfer format consists of the following:

Table 204:
Object 5708_{hex}

Feature	Description
Name	RFID Status
Object code	ARRAY
Data type	Unsigned8
Access	ro
Default value	No
PDO mapping	Yes

13.8 Object 5722_{hex} - 1 byte parameter

The Object 5722_{hex} displays the parameter "Bypass time" to a BL ident[®]-channel.

This parameter setting is only needed when the error message "Dwell period of the tag in the detection range was not sufficient for successful command processing." appears at start-up.

Table 205:
Object 5722_{hex}

Feature	Description
Name	RFID Bypass Time Parameter
Object code	ARRAY
Data type	Unsigned8
Access	rw
Default value	No
PDO mapping	No

14 Manufacturer specific objects

14.1	General.....	2
14.1.1	Module related manufacturer specific objects	2
	– Address assignment	3
14.1.2	Slot-related manufacturer specific objects	4
	– Address assignment	5
14.1.3	Process input objects	5
	– Object 3000 _{hex} - XBInputByte	5
	– Object 3002 _{hex} - XBInputWord	6
	– Object 3004 _{hex} - XBInputDWord0 to Object 300B _{hex} - XBInputDWord8	6
14.1.4	Process output objects	6
	– Object 3020 _{hex} - XBOutputByte	7
	– Object 3022 _{hex} - XBOutputWord	7
	– Object 3024 _{hex} - XBOutputDWord0 to Object 302B _{hex} - XBOutputDWord8	8
14.1.5	Diagnosis objects	9
	– object 3040 _{hex} - XBIDiag Byte	9
	– object 3042 _{hex} - XBIDiagWord	9
	– Object 3044 _{hex} - XBIDiagDword to Object 3047 _{hex} - XBIDiagDword4	9
14.1.6	Parameter objects	10
	– Objekt 3060 _{hex} - XBIParamByte.....	10
	– Object 3062 _{hex} - XBIParamWord	10
	– object 3064 _{hex} - XBIParamDword to object 3069 _{hex} - XBIParamDword8	11

14.1 General

The manufacturer specific objects used in BLxx can be divided into 2 groups:

- module-related manufacturer specific objects ((2000_{hex} to 2FFF_{hex} and 4000_{hex} to 5FFF_{hex})
- slot-related objects (3000_{hex} to 3FFF_{hex})

14.1.1 Module related manufacturer specific objects

The module-related objects (2000_{hex} to 2FFF_{hex} and 4000_{hex} to 5FFF_{hex}) refer to special BLxx device types. They describe special functions for these types of devices which cannot be represented using the device profiles defined by the CiA.

Table 206:
Module-related
manufacturer
specific objects

Object no.		Description
Gateway		
2000 _{hex}	Serial Number	see chapter 4: Device (gateway) objects
2010 _{hex}	Node Reset Modifiers	
2400 _{hex}	System Voltages	
2401 _{hex}	System Voltages	
Analog input modules		
5420 _{hex}	Analog Input Mode	see chapter 8: Objects for analog input modules
Analog outputs		
5440 _{hex}	Analog Output Mode	see chapter 9: Objects for analog output modules
RS232/485/422		
5600 _{hex}	RS232/RS4xx parameters	see chapter 10: Objects for RS232/RS4xx modules
5601 _{hex}	RS232/RS4xx RxD	
5602 _{hex}	RS232/RS4xx TxD	
Encoder (SSI, counter)		
5801 _{hex}	Encoder Config	see chapter 11: Objects for Encoder modules (SSI, CNT)
5802 _{hex}	Encoder Status	
5803 _{hex}	Encoder Flags	
5804 _{hex}	Encoder Diag	
5805 _{hex}	Encoder Native Status	

Table 206:
Module-related
manufacturer
specific objects

Object no.	Description
5806 _{hex}	Encoder Optional Encoder
5808 _{hex}	Encoder Control
5810 _{hex}	Encoder Load Prepare Value
5811 _{hex}	Encoder Pulse Width
5820 _{hex}	Measuring Integration Time
5821 _{hex}	Measuring Low Limit
5822 _{hex}	Measuring High Limit
5823 _{hex}	Measuring Units Per Revolution
5824 _{hex}	Encoder Measuring Divisor
5825 _{hex}	Encoder Measuring Factor
5827 _{hex}	Encoder Measuring Time Out
5830 _{hex}	Encoder Measuring Value
5831 _{hex}	Encoder Latch Value
5840 _{hex}	SSI Diag Mapping
PWM	
5901 _{hex}	PWM Config
5902 _{hex}	PWM Status
5903 _{hex}	PWM Flags
5904 _{hex}	PWM Diag
5908 _{hex}	PWM Control
5910 _{hex}	PWM Load Prepare Value
5913 _{hex}	PWM Duty Cycle
5920 _{hex}	PWM Period Duration
5931 _{hex}	PWM Latch Value

see [chapter 11: Objects for Encoder modules \(SSI, CNT\)](#)

Address assignment

In module-related objects, all modules of one module type within one BLxx-station are counted and considered as one module group. The sub-index of the respective module defines the position of the module within this group (not the slot number).

Example:

A BL20-station contains 3 module type RS232:

To address the parameters of the **2.** RS232 module in the station, object 5600_{hex}, Sub-Index **2** zu wählen.

14.1.2 Slot-related manufacturer specific objects

The slot related objects (3000_{hex} to 3FFF_{hex}) are available for **each** module type in the BLxx-product families. They do **not** depend on the respective device type.

The slot-related objects have to be used for certain device types for which no additional manufacturer specific device-type-related objects are defined (e.g. for parameterization).

The following table shows the slot-related objects for the BLxx-system and defines for which modules they **have to be** used.

Table 207:
Slot-related
manufacturer
specific objects

Object no.	To be used in module-type	
Input objects		
3000 _{hex}	XBIInputByte	
3002 _{hex}	XBIInputWord	
3004 _{hex} to 300B _{hex} ,	XBIInputDWord0 to XBIInputDWord8	
Output objects		
3020 _{hex} ,	XBIOutputByte	
3022 _{hex} ,	XBIOutputByte	
3024 _{hex} to 02B _{hex}	XBIOutputDWord0 to XBIOutputDWord8	
Diagnosis objects		
3040 _{hex} ,	XBIDiagByte	SWIRE, page 12-6
3042 _{hex} ,	XBIDiagWord	
3044 _{hex} to 3 04B _{hex}	XBIDiagDWord0 to XBIDiagDWord8	
Parameter objects		
3060 _{hex} ,	XBIParamByte	SWIRE, page 12-10
3062 _{hex} ,	XBIParamWord	
3064 _{hex} to 306B _{hex}	XBIParamDWord0 to XBIParamDWord8	xDI-NAMUR, page 14-10 xDI-xDO-PD, page 5-2 xXSG-PD, page 5-2 SWIRE, page 12-6
Gateway objects		
3081 _{hex}	XBIReferenceModuleType	
3084 _{hex}	XBIReferenceInputSize	
3085 _{hex}	XBIReferenceOutputSize	
3086 _{hex}	XBIReferenceDiagSize	
3087 _{hex}	XBIReferenceParamSize	
3090 _{hex}	XBICurrentModuleId	

3091 _{hex}	XBICurrentModuleType
3094 _{hex}	XBICurrentInputSize
3095 _{hex}	XBICurrentOutputSize
3096 _{hex}	XBICurrentDiagSize
3097 _{hex}	XBICurrentParamSize

Address assignment

In the slot-related objects, the sub-index defines the slot at which the respective module is located within the BLxx-station.

14.1.3 Process input objects

Object 3000_{hex} - XBInputByte

Table 208:
Object 3000_{hex}

Feature	Description/ Value
Name	XBInputByte
Object code	VAR
Data type	Unsigned8
Access	ro
PDO mapping	
- Sub-index 0	No
- Sub-index 1 and 2	Yes

Object 3002_{hex} - XBInputWord

Table 209:
Object 3002_{hex}

Feature	Description/ Value
Name	XBInputWord
Object code	VAR
Data type	
- Sub-index 0	Unsigned8
- Sub-index 1 and 2	Unsigned16
Access	ro
PDO mapping	
- Sub-index 0	No
- Sub-index 1 and 2	Yes

Object 3004_{hex} - XBIInputDWord0 to Object 300B_{hex} - XBIInputDWord8

Table 210:
Object 3004_{hex}
to 300B_{hex}

Feature	Description/ Value
Name	XBIInputDWordx
Object code	VAR
Data type	
– Sub-index 0	Unsigned8
– Sub-index 1 and 2	Unsigned32
Access	ro
PDO mapping	
– Sub-index 0	No
– Sub-index 1 and 2	Yes

14.1.4 Process output objects

Object 3020_{hex} - XBIOutputByte

Table 211:
Object 3020_{hex}

Feature	Description/ Value
Name	XBIOutputByte
Object code	VAR
Data type	Unsigned8
Access	rww
PDO mapping	
– Sub-index 0	No
– Sub-index 1 and 2	Yes

Object 3022_{hex} - XBIOutputWord

 Table 212:
 Object 3022_{hex}

Feature	Description/ Value
Name	XBIOutputWord
Object code	VAR
Data type	
– Sub-index 0	Unsigned8
– Sub-index 1 and 2	Unsigned16
Access	rww
PDO mapping	
– Sub-index 0	No
– Sub-index 1 and 2	Yes

Object 3024_{hex} - XBIOutputDWord0 to Object 302B_{hex} - XBIOutputDWord8

 Table 213:
 Object 3024_{hex}
 to 302B_{hex}

Feature	Description/ Value
Name	XBIOutputDWordx
Object code	VAR
Data type	
– Sub-index 0	Unsigned8
– Sub-index 1 and 2	Unsigned32
Access	rww
PDO mapping	
– Sub-index 0	No
– Sub-index 1 and 2	Yes

14.1.5 Diagnosis objects

object 3040_{hex} – XBIDiag Byte

The object reads the module's first diagnostic byte on the module bus. The sub-index 1 to 74 corresponds to the slot number of the module in the BLxx-station.

*Table 214:
Object 3040_{hex}*

Feature	Description
Name	XBIDiagByte
Object code	ARRAY
PDO mapping	No
Data type	Unsigned8
Access	ro
Default value	No

object 3042_{hex} – XBIDiagWord

The object reads the module's first diagnostic word on the module bus. The sub-index 1 to 74 corresponds to the slot number of the module in the BLxx-station.

*Table 215:
Object 3042_{hex}*

Feature	Description
Name	XBIDiagWord
Object code	ARRAY
PDO mapping	No
Data type	Unsigned16
Access	ro
Default value	No

Object 3044_{hex} – XBIDiagDword to Object 3047_{hex} – XBIDiagDword4

The object XBIDiagDword reads the first diagnostic-Dword (byte 0...3) of a module on the module bus, XBIDiagDword2 reads the second diagnostic-Dword (byte 4...7) etc.. The sub-index 1 to 74 corresponds to the slot number of the module in the BLxx-station.

*Table 216:
Object 3044_{hex}
to 3047_{hex}*

Feature	Description
Name	XBIDiagDwordx
Object code	ARRAY
PDO mapping	No
Data type	Unsigned32
Access	ro

Table 216:
Object 3044_{hex}
to 3047_{hex}

Feature	Description
Default value	No

14.1.6 Parameter objects

Objects 3060_{hex} „XBIParamByte“ to 306B_{hex} „XBIParamDWord8“ are used to parameterize the BLxx-modules byte-by-byte, word-by-word or Dword-by-Dword.

All modules which have according to the CANopen-profile no parameter objects, **have to be** parameterized using these objects.



Attention

The sub-index corresponds to the slot-number of the BLxx-module within this BLxx-station.



Note

Objects 3000_{hex} to 3097_{hex} allow direct access to the internal module bus of the station.

Objekt 3060_{hex} - XBIParamByte

Table 217:
Object 3060_{hex}

Feature	Description/ Value
Name	XBIParamByte
Object code	ARRAY
Data type	Unsigned8
Access	rw
Default value	No
PDO mapping	No

Object 3062_{hex} - XBIParamWord

Table 218:
Object 3062_{hex}

Feature	Description/ Value
Name	XBIParamWord
Object code	ARRAY
Data type	Unsigned16
Access	rw
Default value	No
PDO mapping	No

object 3064_{hex} – XBIPParamDword to object 3069_{hex} – XBIPParamDword8

Table 219:
object 3064_{hex}
to 3069_{hex}

Feature	Description/ Value
Name	XBIPParam Dword
Object code	ARRAY
Data type	Unsigned32
Access	rw
Default value	No
PDO mapping	No

The structure of the parameter data depends on the respective module.

In the following, the data structure is described for each module-type for which the parameterization using this object is necessary:

■ **BLxx-4DI-NAMUR**

Table 220:
Parameters
BLxx-4DI-
NAMUR

ADefault-
setting

Byte	Bit	Name	Description
0	0	Input filter x	0 = deactivated (input filter 0,25 ms) A 1 = activated (input filter 2,5 ms)
	1	Digital input x	0 = normal A 1 = inverted
	2	Short-circuit monitoring x	0 = deactivated A 1 = activated
1	3	Short circuit diagnosis x	0 = deactivated A 1 = activated
	4	Open circuit monitoring x	0 = deactivated A 1 = activated
	5	Open circuit diagnosis x	0 = deactivated A 1 = activated
2	6	Input on diagnostic x	0 = output substitute value A 1 = hold current value
	7	Substitute value on diag x	0 = off A 1 = on

■ 4DI-PD

Table 221:
Parameters
4DI-PD

ADefault-setting

Byte	Bit	Name	Description
0	0	Input filter 0	0 = deactivated (input filter 0,25 ms) A 1 = activated (input filter 2,5 ms)
	
	3	Input filter 3	
1	0	Digital input 0	0 = normal 1 = inverted
	
	3	Digital input 3	
2	0	Operation Mode Group A	0 = normal A 1 = open-circuit monitoring
	1	Operation Mode Group B	

■ 4DI-PD

Table 222:
Parameters
4DI-PD

ADefault-setting

Byte	Bit	Name	Description
0	0	Input filter 0	0 = deactivated (input filter 0,25 ms) A 1 = activated (input filter 2,5 ms)
	
	3	Input filter 7	
1	0	Digital input 0	0 = normal 1 = inverted
	
	3	Digital input 7	
2	0	Operation Mode Group A	0 = normal A 1 = open-circuit monitoring
	
	3	Operation Mode Group D	

■ 4DI4DO-PD

Table 223:
Parameters
4DI4DO-PD

ADefault-setting

Byte	Bit	Name	Description
0	0	Input filter 0	0 = deactivated (input filter 0,25 ms) A 1 = activated (input filter 2,5 ms)
	
	3	Input filter 3	
1	0	Digital input 0	0 = normal A 1 = inverted
	
	3	Digital input 3	
2	0	Output on overcurrent 0	0 = automatic recovery A 1 = controlled recovery
	
	3	Output on overcurrent 3	

■ **8XSG-PD**

Table 224:
Parameters
8XSG-PD

ADefault-
setting

Byte	Bit	Name	Description
0	0	Input filter 0	0 = deactivated (input filter 0,25 ms) A 1 = activated (input filter 2,5 ms)
	
	3	Input filter 7	
1	0	Digital input 0	0 = normal A 1 = inverted
	
	3	Digital input 7	
2	0	Output on overcurrent 0	0 = automatic recovery A 1 = controlled recovery
	
	3	Output on overcurrent 7	
3	0	Output 0	0 = deactivate A 1 = activate
	
	3	Output 7	

■ **SWIRE**

see [Representation of parameter data \(page 12-10\)](#)

15 Diagnostics - Emergency Frames

15.1	General	2
15.2	Structure of the emergency frames	2
15.2.1	Emergency Error-Codes	2
15.2.2	Error register	4
15.3	Emergency codes for module diagnostics	5
15.3.1	General module error codes	5
15.3.2	Digital output modules	5
15.3.3	Analog Input Modules.....	6
	– Analog input modules, current	6
	– Analog input modules, voltage	6
	– Analog input modules, PT/Ni.....	7
	– Analog Input modules, THERMO/ TC	7
15.3.4	Technology modules	8
	– RS232/RS4xx-modules	8
	– SSI-module.....	8
	– Counter/Encoder/PWM	8
	– SWIRE-module	9

15.1 General

the state of the BLxx-station, the communication through the internal modules bus, the communication with CANopen, the state of the gateway itself.

Diagnostics messages are indicated in two different ways:

- through the individual LEDs, see the additional documentation ([page 1-2](#))
- through Emergency Frames in a CANopen configuration tool (software)

15.2 Structure of the emergency frames

BLxx CANopen supports Emergency Frames (EMCY) as standardized in CiA DS-301.

The COB-IDs for the EMCY telegrams are defined by the Predefined Master-Slave Connection Set:

COB-ID = 129 - 1 + Node-ID

In the event of a communication error, not only the Emergency Error Code but also the Error register (see [Table 225: Bit assignment of the Error register](#)) and additional information will be transmitted, so that the error can be more precisely identified.

Only a part of the 5 bytes is used for the additional information. The remaining bytes are then 0.

Byte	0	1	2	3	4	5	6	7
Data contents	Error code		Error register	Additional information				

15.2.1 Emergency Error-Codes

Designation	0	1	2	3	4	5	Meaning
	Error code (hex.)	Error register (see also Table 225:)	Additional information A, B				
Error reset / no error	0000 _{hex}	bit 0, bit 1 set	"0" or module no. C	Error code			Error reset
Input current too high	2110 _{hex}	bit 0, bit 1 set	module no.	channel no.	0		Input current too high
Input current too low	2130 _{hex}	bit 0, bit 1 set	module no.	channel no.	0		Input current too low
Output current too high	2310 _{hex}	bit 0, bit 1 set	module no.	channel no.	0		Output current too high
Output current out of range	2323 _{hex}	bit 0, bit 1 set	module no.	channel no.	0		Output current below or above the permissible range
Load dump at outputs	2330 _{hex}	bit 0, bit 1 set	module no.	channel no.	0		Output current too low
AI U voltage out of range	3003 _{hex}	bit 0, bit 2 set	module no.	channel no.	0		Input voltage of an AI-module outside of the permissible
Mains voltage too high	3110 _{hex}	bit 0, bit 2 set	0	channel no.	0		System voltage too high

Designation		0	1	2	3	4	5	Meaning
		Error code (hex.)	Error register (see also Table 225:)	Additional information A, B				
Mains voltage too low		3120 _{hex}	bit 0, bit 2 set	module no.	channel no.	0		System voltage too low
Output voltage too low		3320 _{hex}	bit 0, bit 2 set	module no.	channel no.	0		Field voltage too low
Additional modules	SSI / RSxxx Error D	7000 _{hex}	bit 0, bit 7 set	module no.	channel no. (always 1)	Module Error Code		Error in SSI or RSxxx-module (∅ page 15-8 ff.)
	General module error	7010 _{hex}	bit 0, bit 7 set	0	0	0		(→ page 15-5 ff.)
	Change of diagnosis	7011 _{hex}	bit 0, bit 7 set	module no.				
	Module list change ok	707A _{hex}	bit 0, bit 7 set	module no.	0	0		I/O module list, adaptable change, e.g. module removed
Additional modules	Module list change not ok	707D _{hex}	bit 0, bit 7 set	module no.	0	0		I/O module list, incompatible
	Module list extended	707E _{hex}	bit 0, bit 7 set	module no.	0	0		I/O module list extended
	Module list shortened	707F _{hex}	bit 0, bit 7 set	module no.	0	0		1 module removed from I/O module list
Communication warning		8100 _{hex}	bit 0, bit 4 set	2	0	0		CAN communication faulty (at least one of the error counters for the CAN controller of the CANopen gateway has reached the value 96)
Communication transmit timeout		8100 _{hex}	bit 0, bit 4 set	3	0	0		The CANopen gateway was not able to transmit a frame within the specified time
Life guard / Heartbeat error		8130 _{hex}	bit 0, bit 4 set	0	0	0		The CANopen gateway has detected an error in the CANopen Guarding or Heartbeat Protocol, e.g. a time-out.
Recovered from Bus OFF		8140 _{hex}	bit 0, bit 4 set	0	0	0		The system has left the CAN-Bus Off state, i.e. the CAN controller for the CANopen gateway has moved out of this serious fault condition.
External Error		9009 _{hex}	bit 0, bit 4 set	0	0	0		Force Mode is active, i.e. the outputs of the station are not under the control of CANopen at the moment.

AIn total, bytes 3 to 7 of the Emergency Frame can be used to display additional information. At the moment, only byte 3 to 5 are used (if necessary). Byte 6 and 7 are not listed.

Unused bytes of additional information are 0.

BIf the error message is related to the gateway itself (voltage module at the gateway), the value for module- and channel number is "0".

CIn this case, the module number is only displayed, if the previous and already reset error was an error with Error code 7011_{hex}. For all other errors, this byte is "0".

DAn integration of this additional information is only possible, if the type of the respective module can be defined by means of the module number.



Note

The Error code of the Emergency Frame can only be read out using a special analysis tool.

15.2.2 Error register

Table 225:
Bit assignment
of the Error
register

AM = mandatory
BO = optional

Error register	M/O	Meaning
Bit 0	M A	Generate the error message
Bit 1	O B	current error
Bit 2	O	voltage error
Bit 3	O	temperature error
Bit 4	O	communication error (overrun, error state)
Bit 5	O	device-profile-specific error
Bit 6	O	reserved
Bit 7	O	manufacturer-specific error

15.3 Emergency codes for module diagnostics

15.3.1 General module error codes

Designation Meaning	byte 01	Byte 2	Byte 3	Byte 4
General module error General module error	Error code	Error register	Additional information	Additional information
	7010 _{hex}	bit 0, bit 7 set (see also Table 225:)	reserved	channel number for multi-channel modules)
Change of Dia. (change in byte 0 to 3 of the diagnostic data)	7011 _{hex}	bit 0, bit 7 set (see also Table 225:)	Module number	channel number for multi-channel modules)

15.3.2 Digital output modules

Designation Meaning	byte 01	Byte 2	Byte 3	Byte 4
Output current too high: Current too high	Error code	Error register	Additional information	Additional information
	2310 _{hex}	bit 1 set (see also Table 225:)	Module number	channel number for multi-channel modules)
Load dump at outputs: Open circuit or current too low (threshold:	2330 _{hex}	bit 1 set (see also Table 225:)	Module number	channel number for multi-channel modules)



Note

For the exact byte assignment of the Emergency frame, please see "Structure of the Emergency Frames", [page 15-2](#).

15.3.3 Analog Input Modules

Analog input modules, current

Designation Meaning	byte 01	Byte 2	Byte 3	Byte 4
Input current too high: The input current is outside of the permissible range. A	Error code 2110 _{hex}	Error register bit 1 set (see also Table 225:)	Additional information Module number	Additional information channel number for multi-channel modules)
Input current too low: Open circuit or input current (for the measuring range 4 to 20 mA) too low. The threshold is 3 mA.	2130 _{hex}	bit 1 set (see also Table 225:)	Module number	channel number for multi-channel modules)

AThe threshold for this error message is 1% over the upper measuring range value or 1% below the lower measuring range value.



Note

For the exact byte assignment of the Emergency frame, please see "Structure of the Emergency Frames", [page 15-2](#).

Analog input modules, voltage

Designation Meaning	byte 01	Byte 2	Byte 3	Byte 4
AI U voltage out of range: Wire break or the input voltage is outside of the permissible range.	Error code 3003 _{hex}	Error register bit 2 set (see also Table 225:)	Additional information Module number	Additional information channel number for multi-channel modules)



Note

For the exact byte assignment of the Emergency frame, please see "Structure of the Emergency Frames", [page 15-2](#).

Analog input modules, PT/Ni

Designation Meaning	byte 01	Byte 2	Byte 3	Byte 4
Output current too high: Current too high (threshold: approx. 5 Ω; only with temperature measuring ranges)	Error code 2310 _{hex}	Error register bit 1 set (see also Table 225:)	Additional information Module number	Additional information channel number for multi-channel modules)
Output current out of range: The input current is outside of the permissible range. A	2323 _{hex}	bit 1 set (see also Table 225:)	Module number	channel number for multi-channel modules)
Load dump at outputs: Open circuit or current too low (threshold:	2330 _{hex}	bit 1 set (see also Table 225:)	Module number	channel number for multi-channel modules)

AThe threshold for this error message is 1% over the upper measuring range value or 1 % below the lower measuring range value.

**Note**

For the exact byte assignment of the Emergency frame, please see "Structure of the Emergency Frames", [page 15-2](#).

Analog Input modules, THERMO/ TC

Designation Meaning	byte 01	Byte 2	Byte 3	Byte 4
AI U voltage out of range: Wire break or the input voltage is outside of the permissible range. A	Error code 3003 _{hex}	Error register bit 2 set (see also Table 225:)	Additional information Module number	Additional information channel number for multi-channel modules)

**Note**

For the exact byte assignment of the Emergency frame, please see "Structure of the Emergency Frames", [page 15-2](#).

15.3.4 Technology modules

RS232/RS4xx-modules

Designation Meaning	Byte 0 + 1: +Error code	Byte 2 Error register	Byte 3	Byte 4	Byte 5	Meaning
Additional modules	7000 _{hex}	Bit 8 set (see also Table 225:)	module no.	Channel number (always = 1)	08 _{hex}	Parameter error
					10 _{hex}	Hardware failure
					20 _{hex}	Handshake error
					30 _{hex}	Frame error
					40 _{hex}	RX buffer overflow



Note

For the exact byte assignment of the Emergency frame, please see "Structure of the Emergency Frames", [page 15-2](#).

SSI-module

Designation Meaning	Byte 0 + 1: Error code	Byte 2 Error register	Byte 3	Byte 4	Byte 5	Meaning
Additional modules	7000 _{hex}	Bit 8 set (see also Table 225:)	module no.	Channel number (always = 1)	01 _{hex}	SSI-Diag
					02 _{hex}	SSI-Error
					04 _{hex}	Overflow-Error
					08 _{hex}	Underflow-Error
					10 _{hex}	Parameter error

Counter/Encoder/PWM

Designation Meaning	byte 01	Byte 2	Byte 3	Byte 4
Output current too high: Current too high	Error code 2310 _{hex}	Error register bit 1 set (see also Table 225:)	Additional information Module number	Additional information channel number for multi-channel modules)
Output current out of range: The input current is outside of the permissible range. A	2323 _{hex}	bit 1 set (see also Table 225:)	Module number	channel number for multi-channel modules)

SWIRE-module

Designation Meaning	Byte 0 + 1: Error code	Byte 3	Byte 4	Byte 5	Byte 6	Byte 7
Additional modules	7000 _{hex}	module no.	Diag byte 0	Diag byte 1	Diag byte 2 4 6	Diag byte 3 5 7

Bytes 6 and 7 of the Emergency frame contain the result of the bitwise OR relation of the mentioned diagnostic bytes (see Channel number (see [page 12-6 ff.](#))).

16 Index

B	
Boot-up Message	2-10
C	
CANopen	2-1
–Communication	2-2
–EDS-file	2-5
–Emergency object (Emcy)	2-4
–Network Management Messages	2-2
–Process Data Objects (PDOs)	2-3
–Service Data Objects (SDOs)	2-3
–Synchronization object	2-4
–Time stamp object (Time)	2-4
CANopen Standard Objects	3-2
COB-ID	2-8
Communication profile	4-2
D	
Default-mappings	2-16
Default-PDOs	2-16
Default-RPDOs	2-18
Default-TPDOs	2-18
Diagnostic	13-1, 15-1
E	
Emergency-Frame	15-2
Error code	15-2
Error register	15-2, 15-4
Event Timer	2-15
I	
Identifier	2-8
Inhibit Time	2-15
M	
maintenance	1-2
Manufacturer specific objects	4-39
Mappable Objects	2-22
Mapping Objects	2-16
Minimum Boot-up	2-5
N	
Node Guarding	2-9
Node-ID	2-8
O	
Object	4-5
Object dictionary	3-1
objects	
–1000hex – Device Type	4-5
–1001hex – Error Register	4-5
–1005hex – SYNC COB-ID	4-6
–1008hex – Device Name	4-7
–1009hex – Manufacturer Hardware Version	4-8
–100Ahex – Manufacturer Software Version	4-8
–100Chex – Guard Time	4-9
–1011hex – Restore Default Parameters	4-11
–1014hex – Emcy COB-ID	4-12
–1F80hex – NMT Start-up	4-32
–1F81hex – Slave Assignment	4-33
–1F82hex – Request NMT	4-35
–1F83hex – Request Guarding	4-37
–2000hex – Serial Number	4-39
–2010hex – Node ResetModifiers	4-40
–2400hex – System Voltages	4-43
–2401hex – System Currents	4-43
–5420hex – Manu Spec Analog Input Range	8-3
–5440hex – Manu Spec Analog Output Range	9-4
–5600hex – RS232/RS4xx Parameters	10-2
–5601hex – RS232/RS4xx RxD	10-4
–5602hex – RS232/RS4xx TxD	10-7
–6000hex – Read Input 8 Bit	5-4
–6020hex – Read Input Bit (1 to 128)	5-5
–6021hex – Read Input Bit(129 to 256)	5-5
–6022hex – Read Input Bit (257 to 288)	5-5
–6100hex – Read Input 16 Bit	5-6
–6200hex – Write Output 8 Bit	6-4
–6206hex – Error Mode Output 8 Bit	6-5
–6207hex – Error State Output 8 Bit	6-6
–6220hex – Write Output Bit	6-7
–6221hex – Write Output Bit	6-7
–6222hex – Write Output Bit	6-7
–6250hex – Error Mode Output Bit (1 to 128)	6-8
–6251hex – Error Mode Output Bit (129 to 256)	6-8
–6252hex – Error Mode Output Bit (257 to 288)	6-8
–6260hex – Error State Output Bit (1 to 128)	6-9
–6261hex – Error State Output Bit (129 to 256)	6-9
–6262hex – Error State Output Bit (257 to 288)	6-9
–6401hex – Read Analog Input 16 Bit	8-9
–6411hex – Write Analog Output 16 Bit	9-6
–6421hex – Analog Input Interrupt Trigger Selection	8-10
–6422hex – Analog Input Interrupt Source	8-12
–6423hex – Analog Input Global Interrupt Enable	8-13
–6424hex – Analog Input Interrupt Upper Limit	
Integer	8-13
–6426hex – Analog Input Interrupt Delta Unsigned ...	8-14
–6427hex – Analog Input Interrupt Negative	
Delta Unsigned	8-15
–6428hex – Analog Input Interrupt Positive	
Delta Unsigned	8-15
–6443hex – Analog Output Error Mode	9-7
–6444hex – Analog Output Error State	9-8
–67FFh – Device Type	4-38
–6D00hex – Operating Status	11-51
–6D01hex – SingleTurn Resolution	11-51
–6D02hex – Number of Distinguishable	
Revolutions	11-51
–6FFFhex – Device Type	4-39, 11-51
–Analog input modules	8-1
–analog output modules	9-1

Index

–Digital combi modules	7-1
–digital input modules	5-1
–Digital output modules	6-1
–general I/O objects	14-1
–Manufacturer Hardware Version	4-8
–RSxxx modules	10-1
–SSI modules	11-1
operation, safe	1-2

P

Parameter data	11-10
Parameterization through SDOs	2-10
PDO mapping	2-23

R

Receive PDO-Mapping Parameters	4-23
--------------------------------------	------

S

SDO	
–Read	2-9
–Write	2-12
standard objects	2-8
storage	1-2
symbols	1-3

T

Transmission Type	2-14
Transmit PDO-Mapping Parameter	4-29
Transmit PDO-Parameters	4-26
transport, appropriate	1-2

